

Enhancing Nursing Service and Nursing Education in ASEAN

July 2-4, 2013

Associate Professor Yupin Aunguroch, PhD, RN

**ENHANCING NURSING EDUCATION AND NURSING
SERVICE IN ASEAN**

2-4 July 2013

**Assoc.Prof. Yupin Aunguroch, PhD, RN
(Editor)**

ENHANCING NURSING EDUCATION AND NURSING SERVICE IN ASEAN

By: Assoc. Prof. Yupin Aunguroch, PhD, RN

© 2016 **Faculty of Nursing, Chulalongkorn University**

Borommaratchachonnani Srisataphat

Building, Rama 1 Road, Pathumwan,

Bangkok 10330, Thailand

Tel. (662)-218-1131 Fax. (662)-218-1130

Site: www.nurs.chula.ac.th

Editorial Team:

Rungrawee Navicharern, PhD, RN

Joko Gunawan, RN

Cover:

Assoc.Prof. Patpong Navicharern, MD

First Printing 2016

Catalog of Publications

Enhancing Nursing Education and Nursing Service in ASEAN:

Assoc. Prof. Yupin Aunguroch, PhD, RN

X, 283 pages; 18 x 26 cm.

ISBN: 978-602-71191-2-3

All rights reserved. No part of this book may be reproduced in any form or by any electronic or mechanical means including information storage and retrieval systems without permission in writing from the publisher.

PREFACE

This book is the first edition of Nursing Education and Nursing Service in ASEAN. This is the result of International Nursing Symposium involving many nursing leaders from 10 ASEAN countries, conducted by the Faculty of Nursing, Chulalongkorn University.

We believe that the information contained in this book will add the knowledge about Nursing Education and Nursing Service. We, the editors, wish to express our appreciation for all Nursing Leaders from ASEAN joining the symposium, as well the support from ASEAN Studies Center, Chulalongkorn University, and our colleagues and students for their intellectual inspiration and encouragement.

Finally, we must acknowledge that this book would not have been possible without a great effort between us. It has been a most enjoyable seminar and collaboration

Assoc.Prof. Pol.Capt. Yupin Aunguroch, PhD, RN

CONGRATULATORY MESSAGE

Assoc.Prof. Pol.Capt. Yupin Aunguroch, PhD, RN
Dean of Faculty of Nursing, Chulalongkorn University

This symposium occurs because the rapid changes in globalization, which impact lives & health of people around the world, especially people in ASEAN countries. The comings of the ASEAN Economic Community or AEC in 2015 are going to bring more changes to us. The policy of ASEAN community also impact on nursing profession both in nursing education and nursing service, which provide quality of health care for their clients. The awareness of the impact to the clients, Faculty of Nursing, Chulalongkorn University provide the highest level of nursing education in Thailand and provide this international symposium to enhance and strengthen nursing education and nursing service. To achieve this, the objectives of this symposium are:

To develop the network and collaboration between nursing education and nursing service in ASEAN among education, practice and research.

To exchange knowledge of nursing education and nursing service in ASEAN for promoting healthy people under cultural context of ASEAN Community.

To develop guideline of nursing education and nursing service among ASEAN Community for being reference which will lead to benefit among nursing professions in ASEAN.

To direct the development of nursing education and nursing research among educational institute in ASEAN Community.

In this regard, the 10 representative of each nurse leader in ASEAN Community and 3 special lectures from keynote regarding their own background of each countries, health care and nursing system, demand and supply of nursing staff licening and registration, nursing staff development and training. These contents are the need of nursing education and nursing service which is

emphasized during a round table discussion. At the third day, finally, a meeting is conducted to develop the collaboration and network in near future, including to do collaboration research, joint conference, academic exchange, and publish book chapter.

These days, during our spare time, there will be a university tour and I wish you a wonderful opportunity to learn and grow more, and enjoy your stay in Thailand.

CONGRATULATORY MESSAGE

Assistant Professor M.R. Kalaya Tingsabdh

Assistant to the President of Chulalongkorn University

It is my pleasure to be here on behalf of the President of Chulalongkorn University. I thank the Faculty of Nursing, Chulalongkorn University for hosting this International Symposium. I extend my welcome to all of you who join today's event. The ten countries that are members of the Association of Southeast Asian Nations or ASEAN will enter the ASEAN Economic Community or AEC in 2015, leading to the liberalization of trade in services, investment, labor mobility, and greater harmonization of rules and regulations. Thus, a mutual recognition arrangement has been facilitated to promote the common core competencies among 8 sectors and the nursing profession is one of them. With the coming of AEC, nurses need to provide care not only for local people, but also for new groups of clients coming in and out each country from the liberalization. This requires nurses in the ten countries to adjust themselves to the changes. They need to develop nursing knowledge, nursing system applicable to both local and new clients. In addition, they need to prepare a new generation of nurses who are competent for providing nursing care for ASEAN population. In order to achieve these goals, nurse educators and nurse clinicians of the ten countries need to work closely together as a united group. This symposium is the starting point for our long journey. We can share our knowledge, cultures and health care systems, plan our movement together, and reach a promising plan at the end of this seminar. I am delighted to be a part of this significant activity, which Chulalongkorn University is proud to support, and my most thanks go to faculty members and students of the Faculty of Nursing, Chulalongkorn University who make this symposium happen. Now, it's time to declare the International Symposium "Enhancing Nursing Education and Nursing service in ASEAN" open. I wish for the success and long termed collaboration among all of you and ASEAN nurses.

CONTENTS

PREFACE

CONGRATULATORY MESSAGES

- 1 ROLES OF RESEARCH UNIVERSITY TOWARDS LIBERALIZATION OF NURSING SERVICE IN ASEAN 10**
Professor Patcharawalai Wongboonsinand, Ph.D
Professor Kua Wongboonsin, Ph.D
Chulalongkorn University
- 2 NURSING EDUCATION AND NURSING SERVICES FOR HEALTHY POPULATION 23**
Associate Professor Jintana Yunibhand, PhD, RN, APN
President, Nurses' Association of Thailand
- 3 PROFESSIONAL DEVELOPMENT THROUGH NURSING REGULATIONS FOR HEALTHY POPULATION: THAI PERSPECTIVE 43**
Professor Wichit Srisuphan, Ph.D., R.N.
President of Thailand Nursing and Midwifery Council
- 4 NURSING EDUCATION IN BRUNEI DARUSSALAM 54**
Hajah Salmah Hj Mohd Noor
Lecturer (Nursing/Midwifery), PAPRSB Institute of Health Science,
Universiti Brunei Darussalam
- 5 NURSING SERVICES IN BRUNEI DARUSSALAM 63**
HJH Ramlah Binti Kisut
Senior Staff Nurse (Community Health),
RN. Dip. Nursing, Cert. Midwifery, Dip. Community Health Nursing,
Bachelor of Nursing
- 6 NURSING EDUCATION IN CAMBODIA 72**
Virya Koy, RN, MNSc., MHPEd.
Chief Bureau of Nursing and Midwifery, Hospital Services Department,
Ministry of Health. President of Cambodian Council of Nurses
- 7 NURSING SERVICES IN CAMBODIA 85**
Manila Prak BSN, RN
Director of External Program Department, Chairperson of Local Boards,
Angkor Hospital for Children, Siem Reap, Cambodia
- 8 NURSING EDUCATION IN INDONESIA 98**
Dewi Irawaty, MA., PhD.
Faculty of Nursing Universitas Indonesia,

9	NURSING SERVICES IN INDONESIA	107
	<i>Rita Sekarsari SKp., Sp KV., MHSM</i>	
10	NURSING EDUCATION IN LAO PDR	118
	<i>Souksavanh Phanpaseuth</i>	
	<i>Vice Dean for Academic Affairs, Faculty of Nursing Sciences,;University of Health Sciences. Vientiane Capital, Lao PDR</i>	
11	NURSING SERVICES IN LAO PDR	131
	<i>Lamngeun Silavong</i>	
	<i>Nurse Supervisor, Nursing Department, Mahosot Hospital</i>	
12	NURSING EDUCATION IN MALAYSIA	118
	<i>Associate Professor Khatijah Lim Abdullah, Ph.D.</i>	
	<i>Head of Department of Nursing Sciences, Faculty of Medicine, University of Malaya</i>	
13	NURSING SERVICES IN MALAYSIA	148
	<i>Associate Professor Khatijah Lim Abdullah, Ph.D.</i>	
	<i>Head of Department of Nursing Sciences</i>	
	<i>Faculty of Medicine, University of Malaya</i>	
14	NURSING EDUCATION IN MYANMAR	152
	<i>Daw Aye Nyunt</i>	
	<i>Assistant Director (Retired)</i>	
	<i>Executive Member of Myanmar Nurse and Midwife Council; The Republic of the Union of Myanmar</i>	
15	NURSING SERVICES IN MYANMAR	169
	<i>Phyu Phyu</i>	
	<i>Director Nursing, DOH (retired),</i>	
	<i>President Myanmar Nurse and Midwife Council</i>	
	<i>The Republic of the Union of Myanmar</i>	
16	NURSING EDUCATION IN PHILIPPINES	188
	<i>Associate Professor Bethel Buena P. Villarta, Dr.P.H., RN</i>	
	<i>College of Nursing</i>	
	<i>University of the Philippines Manila</i>	
17	NURSING SERVICES IN PHILIPPINES	206
	<i>Maria Rita Villanueva-Tamse, RN, MN</i>	
	<i>University of the Philippine</i>	
	<i>Philippine General Hospital</i>	
18	NURSING EDUCATION AND NURSING SERVICES IN SINGAPORE	221
	<i>Professor Sally Chan, BSc, MSc, PhD, Dip.Ed., RN, RMN</i>	

19	NURSING EDUCATION IN VIET NAM <i>Luong Van Hoan</i> <i>Head of Nursing Department, Faculty of Nursing-Medical Technology;</i> <i>University of Medicine and Pharmacy at Ho Chi Minh City</i>	244
20	NURSING SERVICES IN VIETNAM <i>Huỳnh Thị Phương, MSN, Chief Nurse,</i> <i>Medical Professional Office, Department of Health Ho Chi Minh City</i>	253
21	NURSING EDUCATION IN THAILAND <i>Assoc.Prof. Pol.Capt. Yupin Aunguroch, Ph.D., R.N.</i> <i>Dean, Faculty of Nursing, Chulalongkorn University</i>	265
22	NURSING SERVICES IN THAILAND; THE PREPARATION FOR ASEAN <i>Uraiporn Janta-Um-Mou</i> <i>Bureau of Nursing Ministry of Public Health</i>	276

ROLES OF RESEARCH UNIVERSITY TOWARDS LIBERALIZATION OF NURSING SERVICE IN ASEAN

Professor Patcharawalai Wongboonsinand, Ph.D

Professor Kua Wongboonsin, Ph.D

Chulalongkorn University

Introduction

At the outset, allow me to express my sincere appreciation to the Faculty of Nurses, Chulalongkorn University and the organizing committee for inviting me to be present here today in front of prominent participants from the academic and national nursing associations circles from Thailand and other ASEAN member countries gives me such an immense pleasure. It is also a privilege and honor for me to deliver my thoughts at this timely International Symposium: Enhancing Nursing Education and Nursing Services in ASEAN this morning.

In recent years, ASEAN has regained its profile while transforming into a rule-based organization. It is also exploring ways to enhance connectivity and regional collaboration across the region in order to realize the ASEAN Community by 2015, relying on diversity as strength. At the same time, ASEAN has played a leading role in enhancing regional architecture, such as ASEAN+1, ASEAN+3, East Asia Summit, while exploring an East Asia Free Trade Area to serve as the largest free trade area in the world, with a market of over two billion people, and a combined GDP of almost US\$12 trillion.

The integration of ASEAN to continue in a timely manner was an idea expressed at the 16th ASEAN Economic Ministerial Retreat Meeting on 28 February 2010. As observers across the region pointed out to the ASEAN ministers this integration has been taking place amidst other major developments at both the global and the regional levels. These developments are multi-dimensional and have posed both challenges and opportunities to all of the member countries.

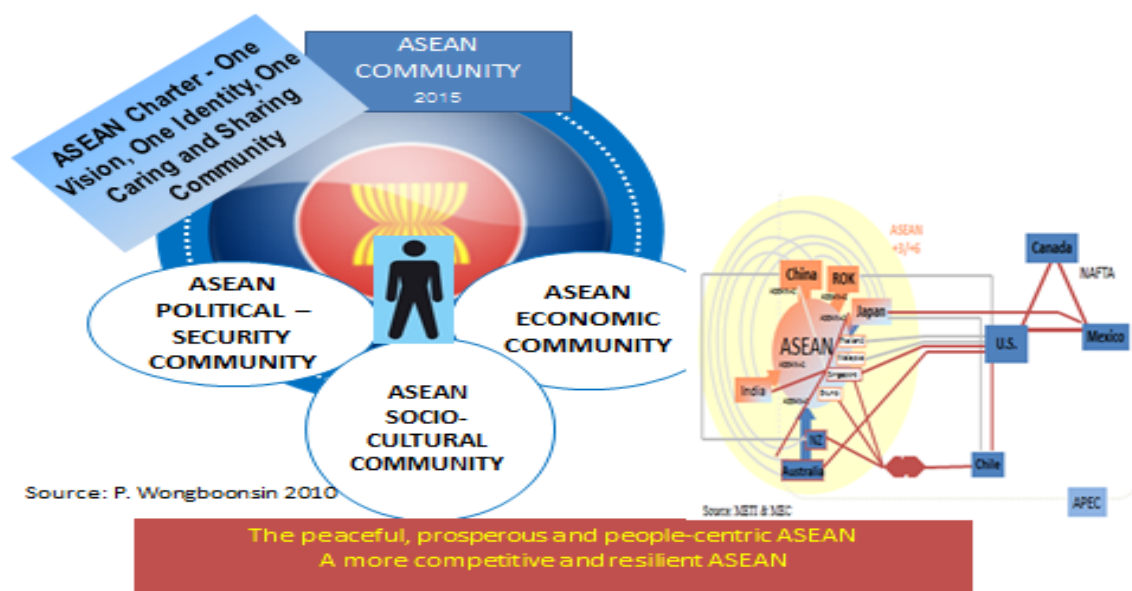

For example, from the perspective of the economic dimension, in recent years, there have been many major developments. After the worst global financial crisis triggered by the Great Depression, ASEAN members and some major Asian economies have turned healthy and resilient. We also see an increasing web of Free Trade Arrangements (FTAs) in the Asia-Pacific region. Many read these as one of the indicators that the center of the global economy is shifting from the Atlantic back to our part of the world as the hub.

On political and security front, it is undeniable that the world is governed by a multi-polar system. The increasing willingness of the major powers to use multilateralism to reach collective solutions to global problems is another important development. This is truly a positive development as most challenges we are facing today are trans-boundary and multi-dimensional in nature ranging

from terrorism to pandemics. Collective effort is, therefore, required in tackling them.

In today's world, the international system has radically changed. Regional groupings are blooming around the world, reflecting the fact that Nation States are in the process of adapting themselves in both reactive and proactive approaches to developments in the more globalized and interdependent world. As one may have realized, it is the world where an individual state cannot deal with a number of challenges alone, whether present or emerging ones. ASEAN with its first Charter is advancing towards the realization of an ASEAN community by 2015. Its three pillars -- ASEAN Political-Security Community, ASEAN Economic Community, and ASEAN Socio-Cultural Community -- form the roadmap for ASEAN Community 2015 to achieve the goal "One Vision, One Identity, One Community." By doing so, ASEAN expects to bring about cooperation in the economic, social, cultural, technical, educational and other fields, coupled with the promotion of regional peace and stability through respect for justice and the rule of law, and adherence to the principles of the United Nations Charter.

ASEAN countries are rich in culture, diverse in language and religion. However, we have determined towards one common goal. That is to be united as one. Regardless all those differences, ASEAN's ten member countries have shared a similar emphasis on population development as a key to repositioning the whole nation towards well-being and competitiveness while entering the knowledge-based economy. It is expected that ASEAN member countries are moving fast enough to be able to deal with the changing global environment. We have realized that we are facing unprecedented challenges, brought by the convergent impacts of globalization, the increasing importance of knowledge as a principal driver of growth and the ICT revolution. I believe you all share with me that none of our economies can grow in isolation.

Role of Education in ASEAN Community

Although the ASEAN Community is based on the three pillars, education appears to be a cross cutting element that support a successful formation of the ASEAN Community. According to the ASEAN Charter, launched in 2007, a closer cooperation in education and human resource development will empower the people of ASEAN and strengthen the ASEAN Community.

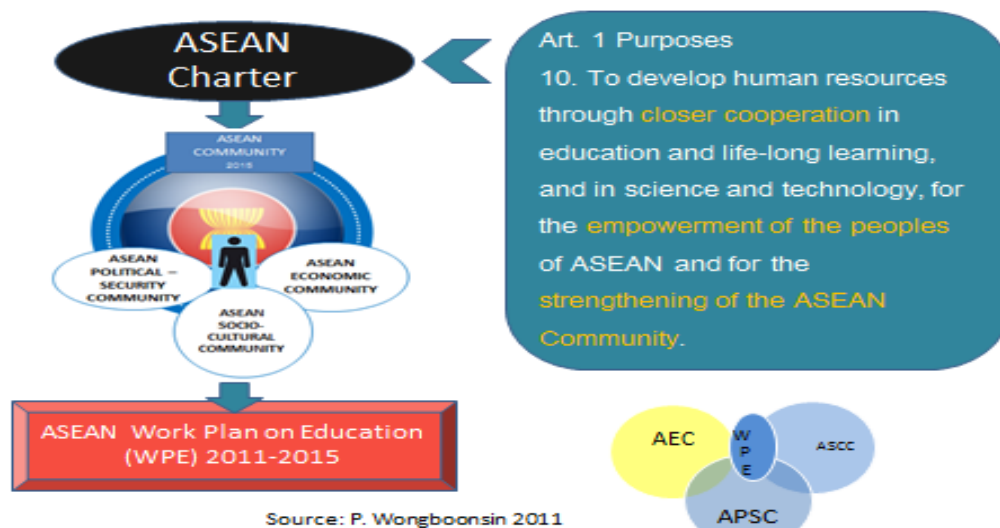

Given the notion that education is a fundamental human right, it is considered very important and strategic for nations to develop their human resources. The right to education imposes an obligation upon each individual nation to ensure that their population at all ages is provided with an opportunity to meet their basic learning needs. Promoting quality and equity in education is a common policy for ASEAN member countries regardless of their different levels of development.

In terms of Higher Education, a broader strategic objective of ensuring the integration of education priorities into ASEAN's development, the Education Objectives aim to advance and prioritize education and focus on: creating a knowledge-based society; achieving universal access to primary education; promoting early child care and development; and enhancing awareness of ASEAN to youths through education and activities to build an ASEAN identity based on friendship and cooperation.

The status of integration of education in ASEAN are being explored and promoted by SEAMEO RIHED, the ASEAN Universities Network (AUN) and a number of prominent research universities across the ASEAN region. The aim is to promote education networking in various levels of educational institutions, continue university networking, enhance and support student and staff exchanges as well as professional interactions including creating research clusters among ASEAN institutions of higher learning. Further actions are envisaged to strengthen collaboration with other regional and international educational organizations to enhance the quality of education in the region.

Education is also viewed as a major engine of economic development. However, governments seem no longer keeping up with demand, and providing free education. At the higher education level, these challenges are common among developing countries:

- Lack of qualified faculty staff
- Declining academic community
- Limited experience of quality assurance processes
- Lack of equitable access for all students
- Lack of infrastructures
- Geographic spread and diversity of universities
- Facility of the usage of English
- Limited research expertise.

I believe you share with me that the above notion is also true in ASEAN, where the majority of member countries still remain developing in terms of economic development. I am of the opinion that human resource development is a key area that requires the strengthening of cooperation in this part of the world. According to the Asian Development Bank, despite a rising level of education attainment across all skills groups, developing ASEAN member countries are suffering from a growing dearth of skills, especially among professional occupations, particularly to provide appropriate nursing services. In the years to come the demographic dividend in this part of the world is not guaranteed. The optimum conditions for a

demographic dividend in Singapore, Thailand and Vietnam have been declining since 2010. Malaysia and Indonesia will be following the trend after the labor-force peak of 63.0% and 65.0% in 2020, respectively.

1st Demographic Dividends in ASEAN

Maximize the opportunity to capitalize on the 1st demographic dividend and minimize the gap of human resource development

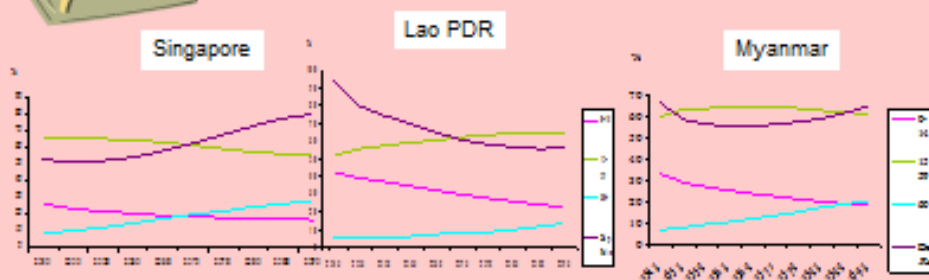

Source: Patcharawala/Wongboonsin 2007

I envisage an ASEAN community that utilizes the pool of its human resources for the region's wealth, prosperity and international competitiveness. I envisage the diversity of our cultural heritage that underpins our inner strength. I envisage an ASEAN community that is not an exclusive community but one which is inclusive, and working not only towards its own prosperity but also to promote global prosperity.

There are challenges that undermine ASEAN competitiveness and strength in enhancing prosperity and development within the continent and beyond. Among others, the strengthening of people-centered development is considered the first core area of cooperation. This is particularly focused on the improvement of quality of life in ASEAN.

Utilization of ASEAN resources and advancement of research and development, science and technology is another core area of cooperation.

Moreover, the softer side of building networks and linkages across ASEAN region such as cultural and educational exchanges and tolerance of diversity should also be encouraged. The comfort level for participation in forums of academic-professional nature has also enhanced relationship among its members as well as their human resources, with the hope of resolving any historical misunderstanding.

Liberalization of Educational Services

Education is expected to play a significant role in narrowing the development gap in ASEAN while the region is moving towards the ASEAN Community in 2015. Against this background, ASEAN members are negotiating intra-regional services liberalization in several sectors, including educational services as well as such professional services as nursing to meet the objectives of the ASEAN Framework Agreement on Services (or AFAS in short).

Such objectives include:

To enhance cooperation in services amongst ASEAN Member Countries in order to improve the efficiency and competitiveness, diversify production capacity and supply and distribution of services of their services suppliers within and outside ASEAN; and

To eliminate substantially the restrictions to trade in services amongst ASEAN Member Countries; and to liberalize trade in services by expanding the depth and scope of liberalization beyond those undertaken by ASEAN Member Countries under the General Agreement on Trade in Services (hereinafter referred to as "GATS") with the aim to realizing free trade in services

ASEAN member countries have tabled their commitments to minimize restrictions on the provision of educational and nursing services across the region. It is expected that they would progressively intensify their integration commitment for the free flow of education services and free flow of professionals

in the region so that ASEAN as a whole would become an important player in the global supply chain.

ASEAN MRAs And MRA Framework	Professional Services	Date
Mutual Recognition Arrangement (MRA)	Engineering Services	9 Dec 2005
Mutual Recognition Arrangement (MRA)	Architectural Services	19 Nov 2006
Mutual Recognition Arrangement (MRA)	Nursing Services	8 Dec 2006
Mutual Recognition Arrangement (MRA)	Medical Practitioners	25 Jul 2008
Mutual Recognition Arrangement (MRA)	Dental Practitioners	25 Jul 2008
Framework Arrangement for the Mutual Recognition	Surveying Qualifications	19 Nov 2006
MRA Framework	Accountancy Services	25 Jul 2008

Provision of nursing care by a nurse

- Promotive, preventive, curative and rehabilitative practices which may include

- education and
- research.

Recognized the ASEAN Vision 2020 on Partnership in Dynamic Development, ASEAN Mutual Recognition Arrangement on Nursing Services is now in place. The MRA notes that the Article V of AFAS provides that ASEAN Member Countries may recognize the education or experience obtained, requirements met, and license or certification granted in other ASEAN Member Countries, for the purpose of licensing or certification of service suppliers. The objectives intended under this MRA are four-fold. That is to:

1. Facilitate the mobility of nursing professionals within ASEAN;
2. Exchange information and expertise on standards and qualifications;
3. Promote adoption of best practices on professional nursing services; and
4. Provide opportunities for capacity building and training of nurses.

According to the MRA, a Foreign Nurse may apply for registration or license in a Host Country to be recognized and allowed to practice nursing in accordance with the laws and regulations of the Host Country concerned, subject to the following 6 conditions are met:

1. Granted a Nursing Qualification;

2. Possession of a valid professional registration and/or license from the Country of Origin and a current practicing license or certificate or any relevant certifying documents;

3. Minimum practical experience in the practice of nursing of not less than three (3) continuous years prior to the application;

4. Compliance with satisfactory continuing professional development in accordance with the Policy on Continuing Professional Development in nursing as may be mandated by the NRA of the Country of Origin;

5. Certification from the NRA of the Country of Origin of no record or pending investigation of having violated any technical, professional or ethical standards, local and international, for the practice of nursing; and

6. Compliance with any other requirements, such as to submit for a personal medical examination or undergo an induction program or a competency assessment, as may be imposed on any such application for registration and/or license as deemed fit by the NRA or any other relevant authority or the Government of the Host Country concerned.

The Practice of Nursing refers to the provision of nursing care by a nurse that encompasses promotive, preventive, curative and rehabilitative practices which may include education and research.

The notions are particularly relevant to the role nursing education and the role of research universities in the region to hold hand in hand for both the stock and flow of nurses to reap the benefits integration will bring about, to face the challenges that it will create, as well as to perform their appropriate role to contribute proactively and efficiently to the well-being of people from all walks of life in the region.

Intra-Regional Cooperation in Capacity Building among Research Universities: Nursing Education

As we may have realized, a number of countries across the globe are moving through educational generations of higher education, from Education 1.0 to Education 4.0.

For your information, although they are comparatively very different, they are interactive. As noted by Moravec and Harkins at the University of Minnesota, Education 1.0 is a largely one-way process of teaching and learning. Students are largely consumers of information resources. They engage in activities based around information sources that are delivered to them by lecturers and gain experience with memorization.

Educational Generations in Higher Education

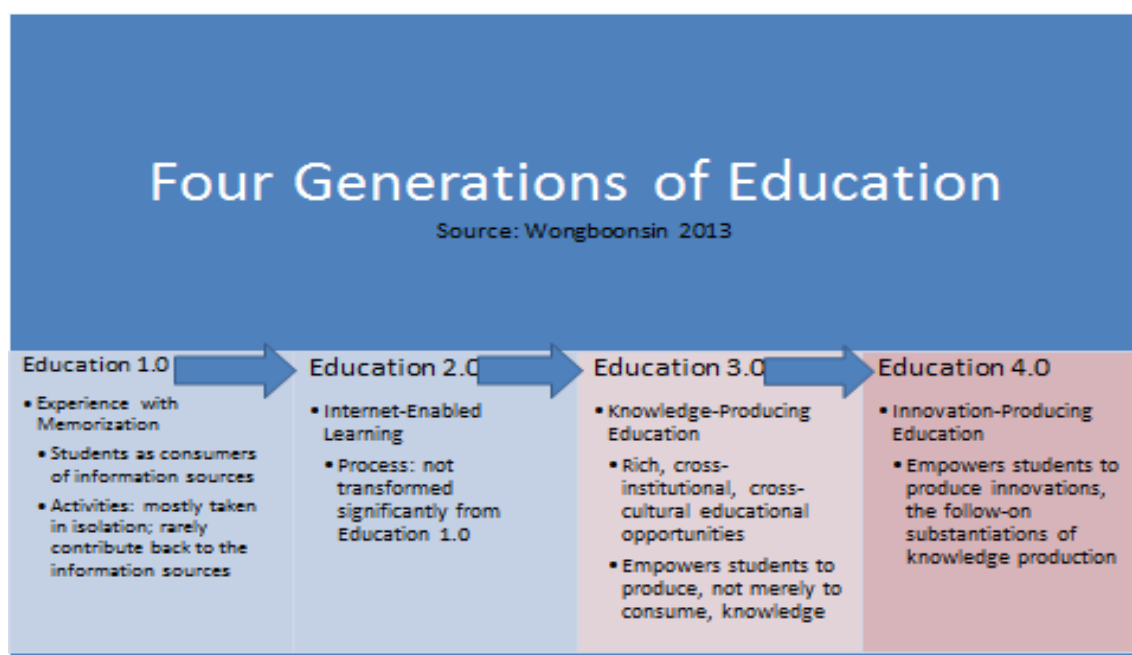

Education 2.0 takes place when the technologies of Web 2.0 are used to enhance traditional approaches of education. The process of education itself is not transformed significantly from Education 1.0, although the groundwork for broader transformation is being laid down.

Education 3.0 empowers students to produce, not merely to consume, knowledge. It is made possible by Education 2.0, and by centuries of experience with memorization. It is characterized by rich, cross-institutional, cross-cultural educational opportunities within which the students play a key role as creators of

knowledge artifacts that are shared, and where social networking and social benefits outside the immediate scope of activity play a strong role.

Education 4.0 empowers students to produce innovations, the follow-on substantiations of knowledge production. Students are as a major source of technology evolution in the service of innovation production.

As one may note, Education 2.0 is a necessary foundation for Education 3.0 and Education 4.0. Although parts of education in ASEAN are moving toward Education 2.0, it is necessary to for us to leapfrog toward Education 3.0 and Education 4.0, for institutions of higher education across the region to collaborate to empower students toward human capital competent in knowledge production, innovation production, and innovative knowledge applications, in such a field as nursing services.

Intra-regional Cooperation in Capacity-Building among Research University

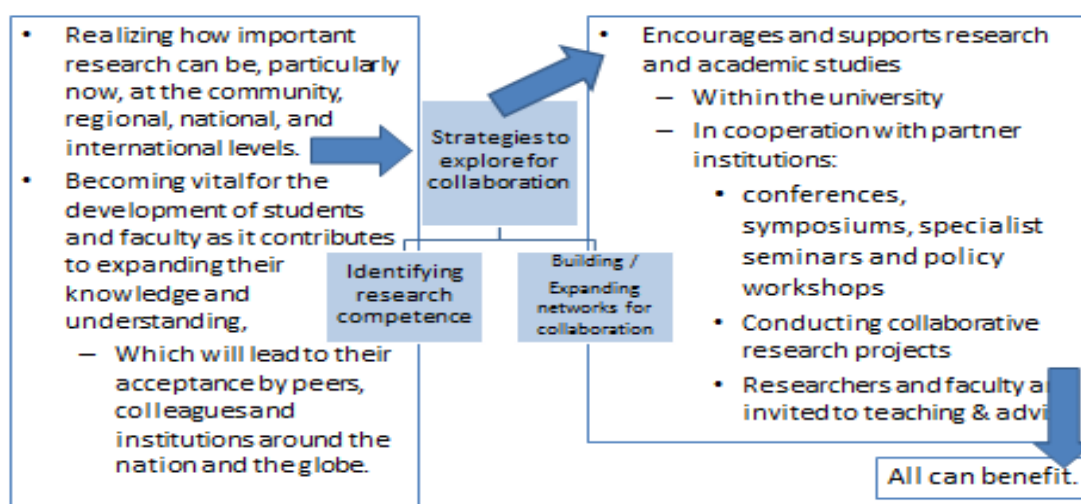

We have so far realized how important research can be, particularly now, at the community, regional, national, and international levels, and that it is becoming vital for the development of students and faculty as it contributes to expanding their knowledge and understanding, which will lead to their acceptance by peers, colleagues and institutions around the nation and the globe. It is

accordingly imperative for us all to explore strategies for collaboration on a network basis. A symposium as we are doing here is to be encouraged so as to lead to collaborative research projects contributing to healthy ASEAN population.

Concluding Remarks

Against the backdrop of multilateralism and the dynamic trend of world competitive knowledge-based economy, ASEAN member countries are moving towards an ASEAN Community. Although the ASEAN Community is based on three pillars, education appears to be a cross cutting element that support a successful formation of the ASEAN Community. Liberalization of educational services and nursing services is expected to contribute to ASEAN Economic Community, while education is part of ASEAN Socio-cultural Community. ASEAN MRA on nursing services include education and research as part of the practices nursing besides promotive, preventive, curative and rehabilitative practices. This is considered particularly relevant to the role of research universities in ASEAN. They need to strengthen their collaboration on a network basis in nursing education so that the stocks and flows of nursing practitioners would be able to maximize the opportunities provided in ASEAN liberalization of nursing services while proactively contributing to healthy ASEAN population and ASEAN Community.

References

- Harkins, A. M. (2008). "Leapfrog Principles and Practices: Core Components of Education 3.0 and 4.0." *Futures Research Quarterly* draft VIII, 28 March 08. Available from <http://leapfrog.umn.edu/Documents/HarkinsCoreComponents.pdf>.
- _____ and Moravec, J. (2006). "Building a 'Leapfrog' university v6.0." Available from <https://wiki.umn.edu/twiki/bin/view/Leapfrog/MemoV6>.

- METI & MEC (n.d.). "Hubs and Spokes in Asia Pacific," cited in Michael Ewing-Chow (n.d.). "The ASEAN Economic Community after the ASEAN Charter, Trading Bloc or Blocked?"
- Wongboonsin, K. (2013). "Building Capacity Across Thailand Researchers: Bridging the Gaps and Expanding Cooperation" Power point presentation at the International Conference on Education. (2013). "Education for Our Future" organizes by Office of the Education Council and British Council. 23 – 25 June 2013. Centara Grand and Bangkok Convention Centre CentralWorld, Bangkok.
- Wongboonsin, P.(2007). "Labor Market and Demographic Dividend in ASEAN."Mimeo.College of Population Studies, Chulalongkorn University,
- Wongboonsin, P. (2010). "ASEAN Community from A Population-Development Perspective." College of Population Studies, Chulalongkorn University.
- Wongboonsin, P. (2011). "Role of Education in ASEAN Community."College of Population Studies, Chulalongkorn University.

NURSING EDUCATION AND NURSING SERVICES FOR HEALTHY POPULATION

*Associate Professor Jintana Yunibhand, PhD, RN, APN
President, Nurses' Association of Thailand*

As advances in nursing science and research impact upon nursing education and clinical practice, clear understanding in nursing discipline can lead to the way to improve these. Discipline is a unique perspective or way of viewing something. It is a body of knowledge, practice, and system of rules. It defines the boundaries in which we practice. In order to provide an effective nursing service, we use nursing knowledge that involved with nursing discipline and the profession.

Nursing: The discipline and the profession

Nursing is a discipline and a profession. The goal of the discipline is to expand knowledge about human experiences through creative conceptualization and research. This knowledge is the scientific guide to living the art of nursing. The discipline-specific knowledge is a given birth and fostered in academic setting where research and education move the knowledge to new realms of understanding. The discipline of nursing encompasses the knowledge in the extant frameworks and theories explicating the nature of nursing's major phenomena of concern, the human-universe-health process.

The goal of the profession is to provide service to mankind through living the art of the science. The profession of nursing consists of persons educated in

the discipline according to the nationally regulated, defined, and monitored standards. The standards and regulations are to preserve healthcare safety for member of society.

Members of the nursing profession are responsible for regulation of standards of nursing practice and nursing education based on disciplinary knowledge that reflects safe health service to society in all settings.

Nursing and the Society

Although the discipline and the profession of nursing have different goals, the reason of existence of nursing is the enhancement of quality of life of humankind. The discipline provides the science lived in the art of practice. Nursing is a noble profession significant for any society.

Nurses and Midwives

Nursing: The discipline and profession

Midwifery: The discipline and profession

Nursing and Midwifery Council

Nursing and Midwifery Association

Nursing and Midwifery Union

Nursing for Health and Society

The Nursing house (the illustration as the following) has the goal for health and society. Nurses work to serve these three pillars which consist of policy and planning, education and training, and manpower development and utilization. In this case, we need to plan for the workforce issue that we plan the number of graduate nurses, how to utilize nursing service, number of nurse/population, plan for preventing mal-distribution.

This obviously showed that nursing service is the root of this house, so we need to have an excellence education, need the support from the leader to sustain the house. Without the support among colleague will make we lost the energy.

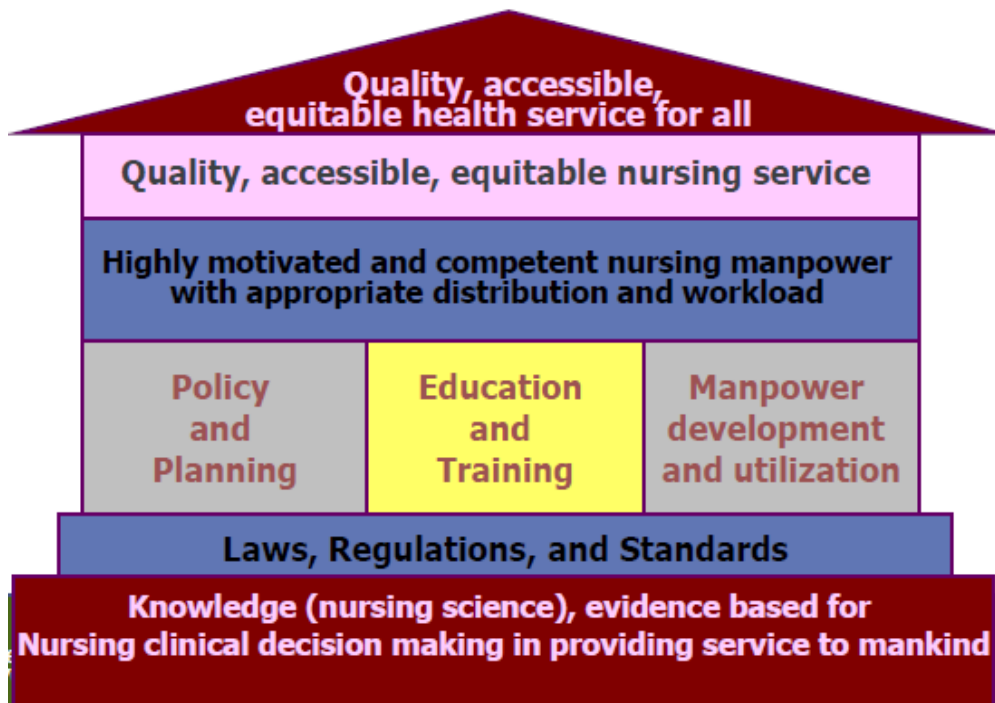

Nursing and Midwifery Services

A subsystem of health services is provided by a range of personnel. Globally, these services share common attributes that include: 1) Caring for, supporting and comforting clients; 2) Continuously assessing and monitoring health needs and responses to interventions; 3) Advocacy and education of clients and communities ; 4) Identifying care gaps and developing appropriate responses; 5) Delivering and coordinating health services across the care spectrum; and 6) Nursing and midwifery also complement and support other health care services and thus help to ensure the successful implementation of interventions that welcome life, promote or restore health or, conversely, enable the means to a peaceful, dignified and pain-free death. However, there still has some matter while confronting with nursing and midwifery education.

Critical Matters Confronting Nursing and Midwifery Education

The most critical matters confronting nursing and midwifery education: 1) Directions: Policy and planning; 2) Curriculum: Occupation VS Professional education; 3) Faculties: Shortage of qualified faculty, aging faculty; and 4) Students: good academic achievement and positive attitude toward nursing profession.

Nursing Education

Regarding the 12th ASEAN Joint Coordination Committee on Nursing Service meeting (24-27 September, 2012 at KL – Malaysia), there has proposed

ICN Framework of Competencies



ICN Framework of competencies which are ICN Framework of Competencies: RN to APN. This framework is concerned about: professional, ethic, legal practice.

Care provision and management

It consisted of two main parts which are principles of care and leadership and management. In the part of nursing service which is concerned about nursing for Health and Society.

Critical matters confronting nursing and midwifery services

A review of the literature and consultation with a variety of stakeholders by WHO. The most critical matters confronting nursing and midwifery services included: Service delivery, Workforce, Education, Stewardship.



Professional, personal, and quality development



Nursing service delivery system

Nursing service delivery system was designed according to the nationally regulated, defined, and monitored standards. The standards and regulations are to preserve healthcare safety for member of each society. For instance: ASEAN workforce: we organized various activities to make a channel for discussion on workforce issue such as: ICN-Asia Workforce Forum & Asia Alliance of Nurses Association, Yearly meeting

ICN Workforce Forum Nursing Workforce Profile Data (2005-2011):

(Elizabeth Adams; Consultant Nursing and Health Policy International Council of Nurses, and the Asia National Nursing Associations)

The International Council of Nurses (ICN) is a federation of more than 136 national nurses associations (NNAs), representing the more than 16 million nurses worldwide. ICN was founded in 1899. ICN is the world’s first and widest reaching international organization for health professionals.

ICN Vision:

United within ICN, the nurses of all nations speak with one voice.

The International Council of Nurses is set to serve as a hub for the international exchange of ideas, experience and expertise for the nursing professional.

ICN operated by nurses for nurses, ICN works to ensure quality nursing care for all, sound health policies globally, the advancement of nursing knowledge, and the presence worldwide of a respected nursing profession and a competent and satisfied nursing workforce

ICN's Mission:

“To represent nursing worldwide, advancing the profession and influencing health policy”.

ICN Goals:

ICN goals include: To bring nursing together worldwide, To advance nurses and nursing worldwide, and To influence health policy.

ICN advances nursing, nurses and health through its policies, partnerships, advocacy, leadership development, networks, congresses, special projects, and by its work in the arenas of professional practice, regulation and socio-economic welfare.

ICN Values

ICN values include Visionary Leadership, Inclusiveness, Flexibility, Partnership, and Achievement

ICN Strategies

ICN has chosen a networking mechanism to do this because networks are about: Getting to know people outside your immediate circle of contacts;

Establishing and using contacts for information, support and other assistance; Building relationships; and most importantly networks; and Communication.

ICN Actions

Identify issues early and monitor how they develop: Follow trends; Offer special expertise through creating a resource pool from network members; Disseminate ICN's and others' work in the area of interest; and Organize meetings and conferences.

ICN is particularly active in:

A. Professional Nursing Practice: International classification of nursing practice - ICNP®; Advanced nursing practice; Entrepreneurship; Women's health; Primary health care; Family health, and Safe water.

B. Nursing Regulation: Regulation and Credentialing; Code of ethics, standards and competencies; and Continuing education.

C. Socio-economic Welfare for Nurses: Occupational health and safety; Human resources planning and policy; Remuneration, salary and wages; Career development; and International trade in professional services.

Activities of ICN

The activities of ICN include: CN congress, ICN International Conference and CNR, ICN Workforce Forum, International Regulation, Nursing Leadership Training Conference, Creative Nursing guidelines, and International Classification Nursing Practice ICNP.

ICN Workforce Forum Nursing Workforce Profile Data (2005-2011):

(Mary May BSN, RN; ICN Intern University of Michigan Graduate Student, Elizabeth Adams; Consultant Nursing and Health Policy International Council of Nurses). There are 10 major categories: 1) General Information; 2) Employment Status; 3) Age Profile; 4) Principal Employer; 5) Nurse

Employment; 6) Projected Nurse Supply; 7) Changes in Nurse Demand; 8) Turnover Rates; 9) Nurse Immigration; and 10) Nurse Migration

1. General Information

There is a survey on nursing workforce information.

- Category of Nurses (RN only)
- Years of Education

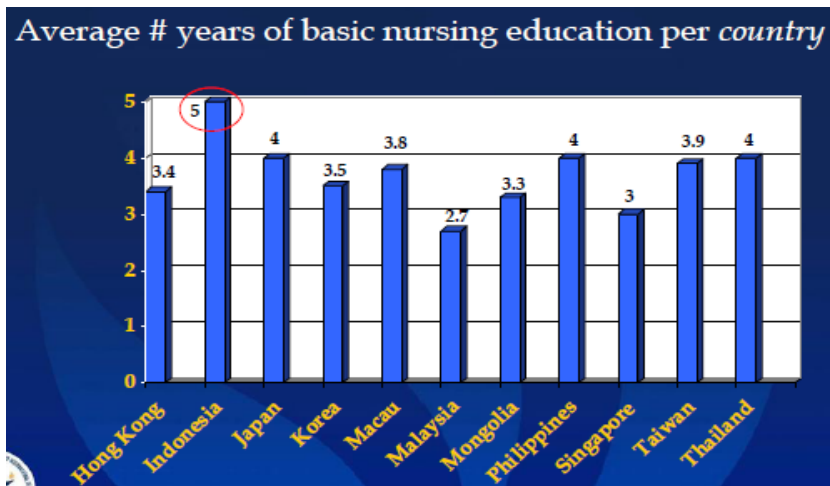
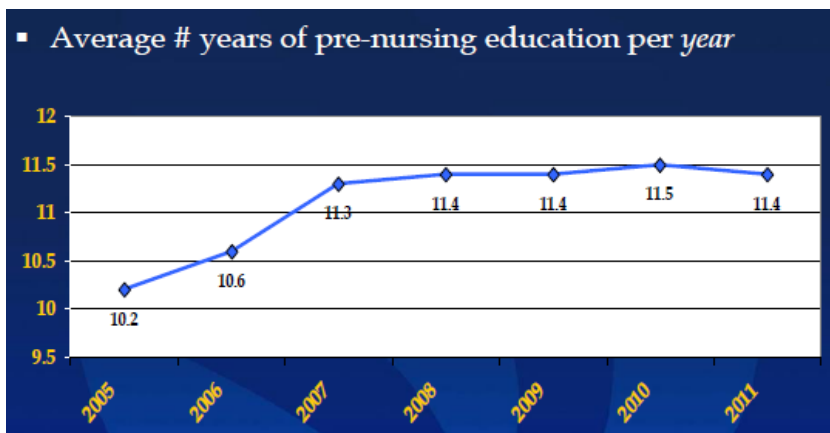
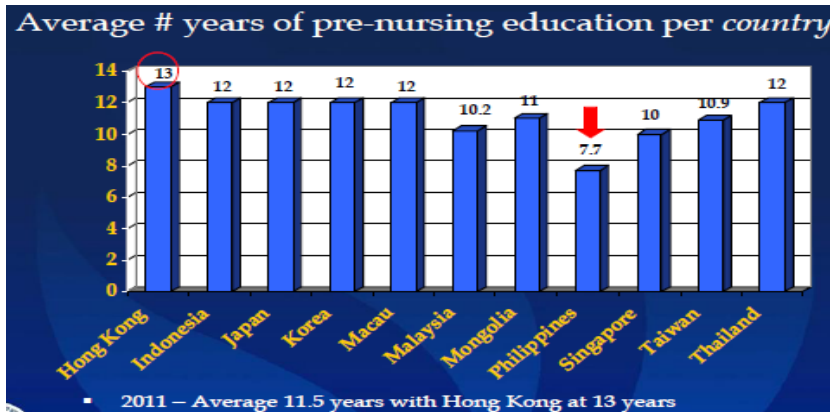

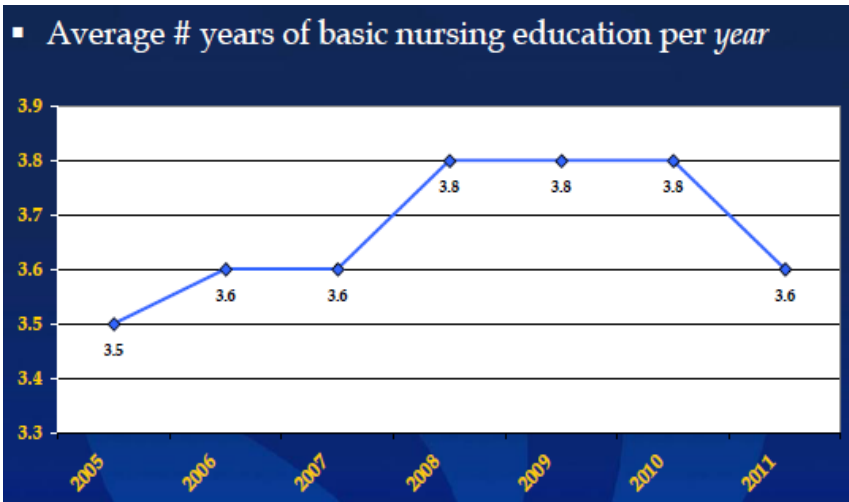

- Number of Nurses per Country (male/female)

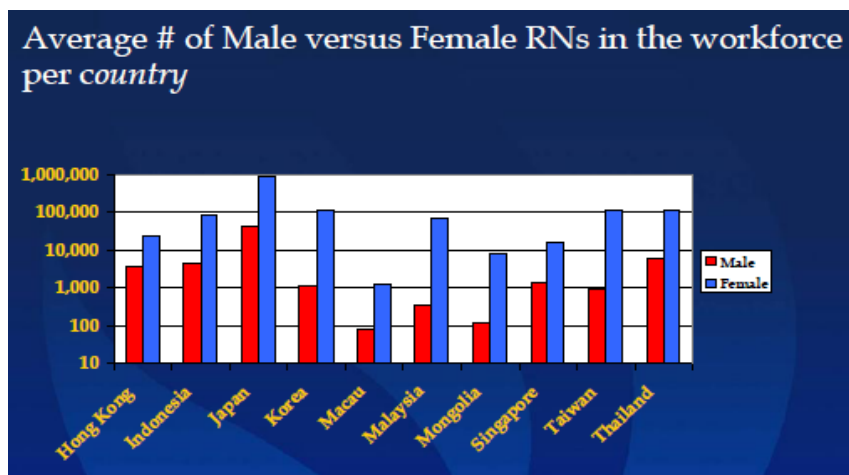

- RN/total population ratio

RN : total population ratio (per 2010 data)

Hong Kong	4.1 : 1,000
Indonesia	.4 : 1,000
Japan	7.4 : 1,000
Korea	3.1 : 1,000
Macau	2.8 : 1,000
Malaysia	2.8 : 1,000
Mongolia	3.2 : 1,000
Philippines (2006)	4.3 : 1,000
Singapore	2.9 : 1,000
Taiwan	4.5 : 1,000
Thailand	2.2 : 1,000

2. Employment Status

- Full-time/Part-time
- Overtime hours
- Employed new graduates

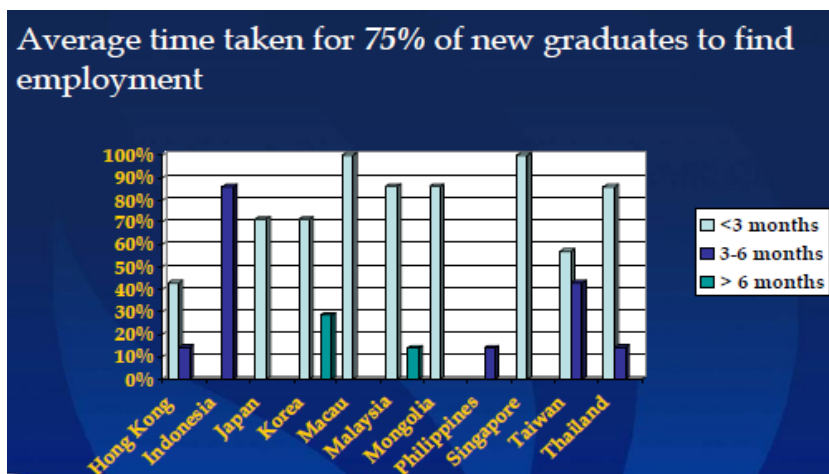
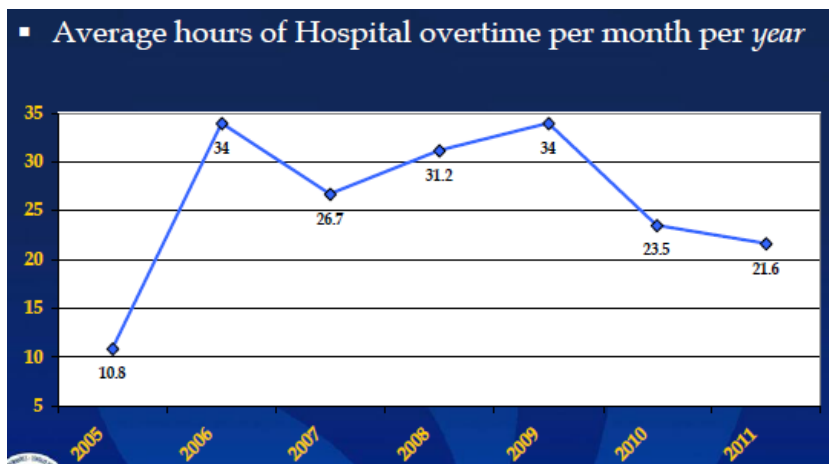
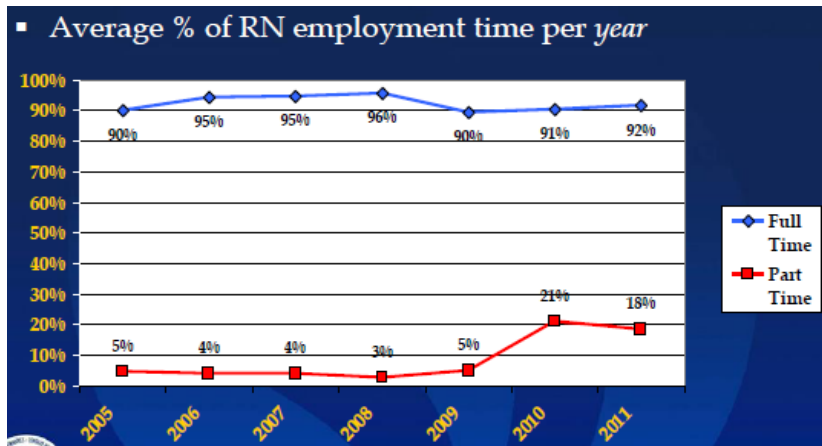

Average hours of Hospital overtime per month per country

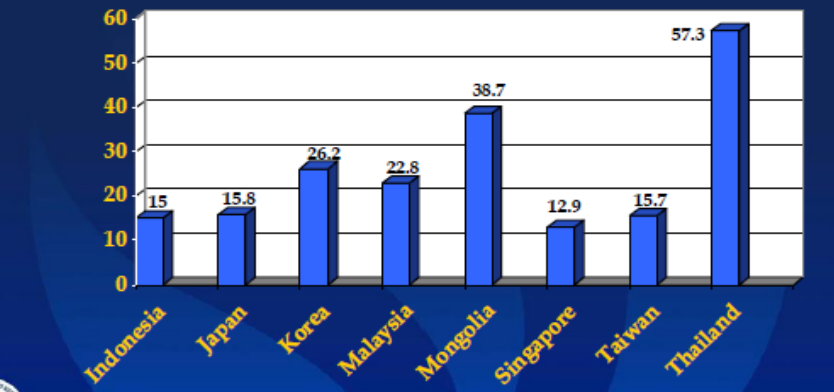

3. Age Profile

- Average age of an employed nurse
- Retirement age: by contract, by law, by practice, and early retirement
- Average professional life in nursing

Average RN employment age per country

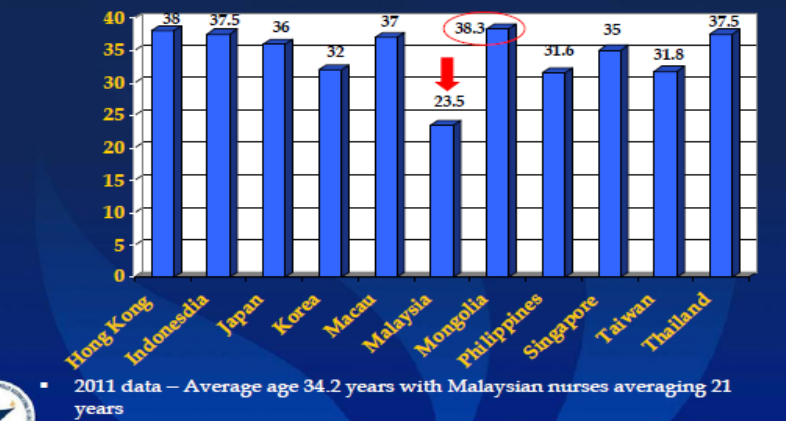

Average retirement age 'in practice' compared to 'by law' per year

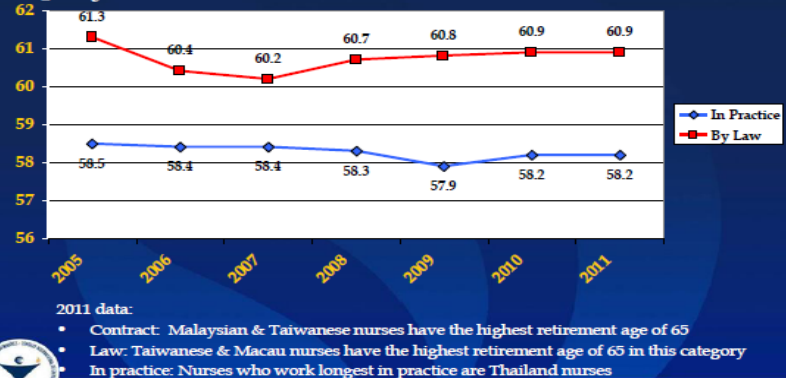



4. Principle Employer

- Private Sector
- Public Sector
- Areas of Employment: Hospital, Nursing Home, Home/Community, Physicians Office, and other

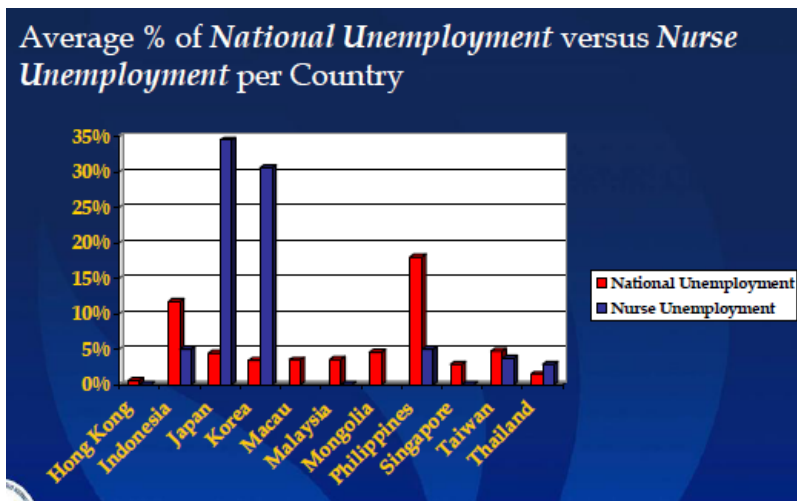
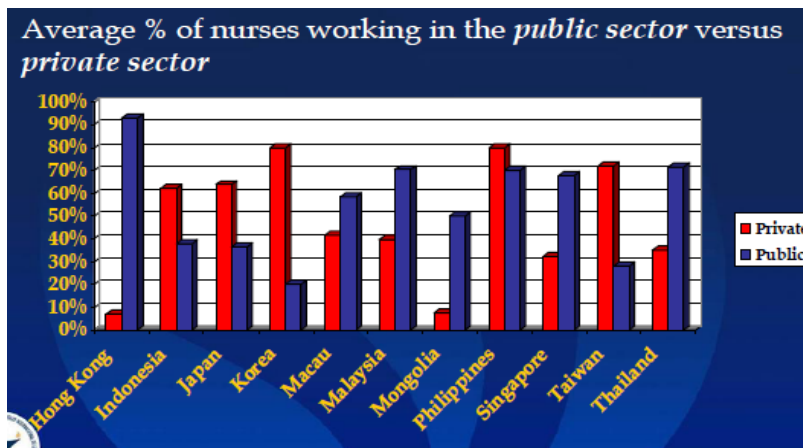

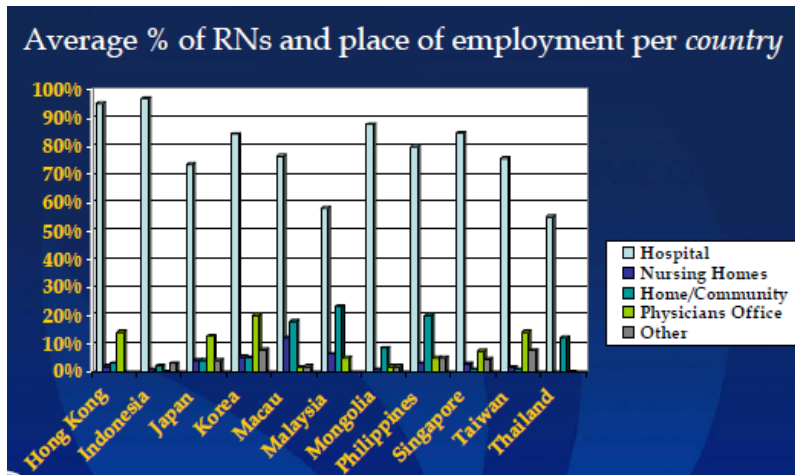

5. Nurse Unemployment

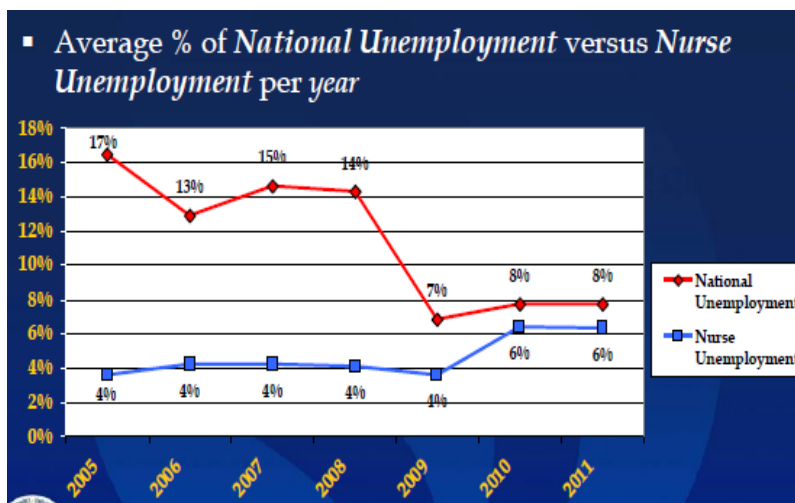

6. Projected Nurse Supply

Examines three different areas: Nurse Supply ‘In Balance’; Nurse Supply ‘In Surplus’; Nurse Supply ‘In Shortage’; 1 year, 5 year, and 10 year increments.

‘In Balance’ (5-10 years): Indonesia, Korea, Macau, Mongolia, Singapore, and Taiwan

‘In Surplus’ (5-10 years): Malaysia, Philippines, and Taiwan

‘In Shortage’ (5-10 years): Hong Kong, Korea, Malaysia, Thailand

7. Nursing Demand

Examines six different areas: Demography, Health Needs, Patient Care, Technology, Government Policy, and other. The most common reason for

changes in nursing demand: Demography, Health Needs, Patient Needs, and Technology

8. Turnover Rate

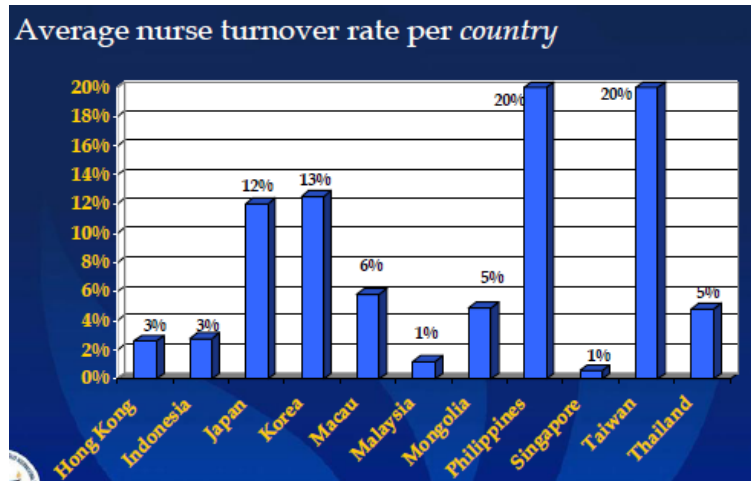

9. Nurse Immigration

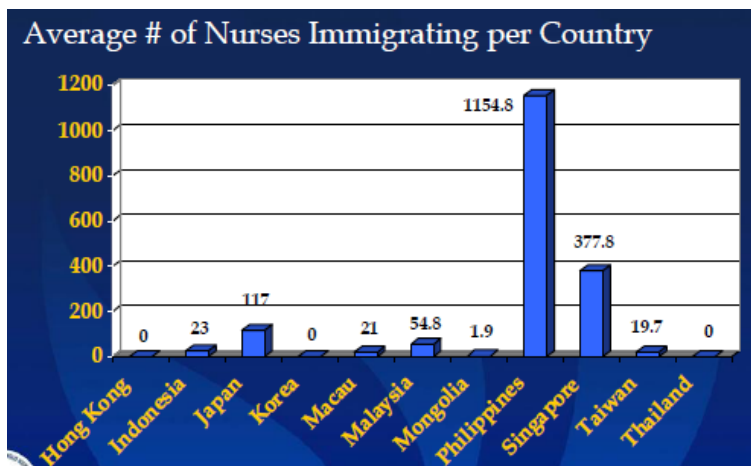

10. Nurse Migration

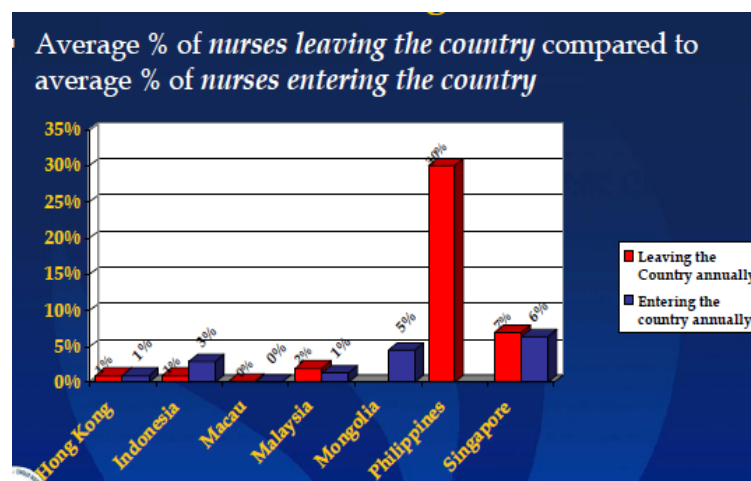

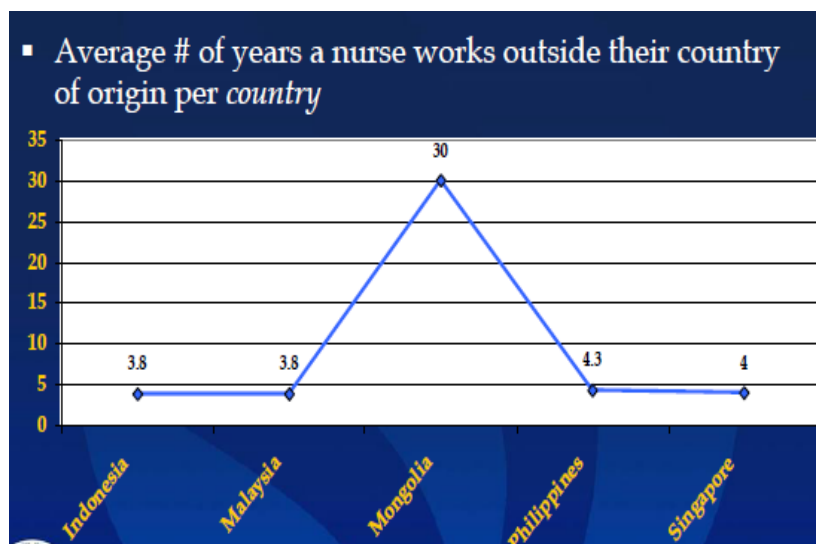

Asian Workforce Forum Nurse Wages :

(Elizabeth Adams; Consultant Nursing and Health Policy International Council of Nurses, and the Asia National Nursing Associations)

Purchasing Power Parity Exchange: All the data used is presented using PPP; The adjustments are meant to give a better picture than comparing gross domestic products (GDP) or salaries using market exchange rates! Please note that this type of adjustment to an exchange rate is controversial; and The most current PPP rates:

<u>PPP</u>	<u>Amount</u>
Hong Kong	5.43 (2011)
Indonesia	5734.2 (2009)
Japan	106.82 (2011)
Korea	809.44 (2011)
Macau	4.05 (2011)
Malaysia	1.85 (2011)
Mongolia	612.72 (2008)
Philippines	24.62 (2010)
Singapore	1.01 (2011)
Taiwan	16.5 (2011)
Thailand	17.64 (2011)

Overview that we need to concern: Average salary, Starting salary within sectors, Comparing salaries, Salary by profession, Number of hours worked, Principal bargaining structure, Inflation rate

1) Average Salary

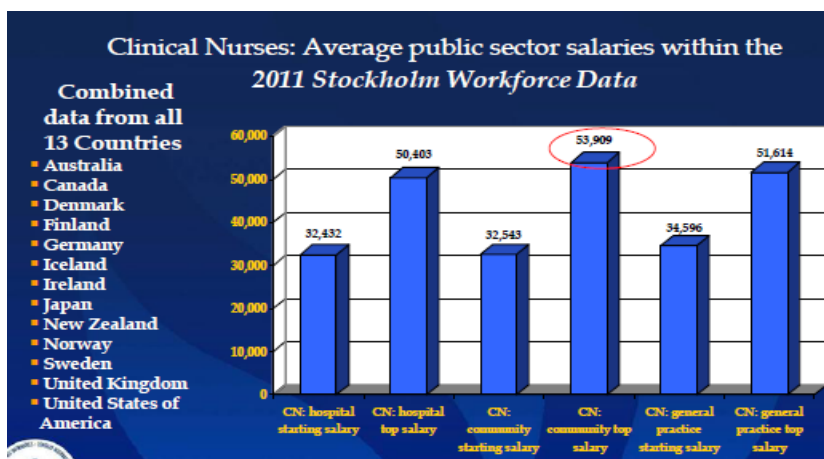
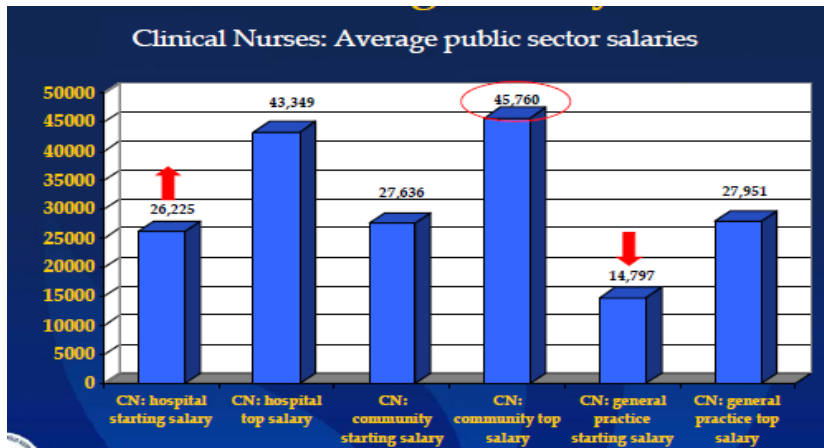

2. Salary within Sectors

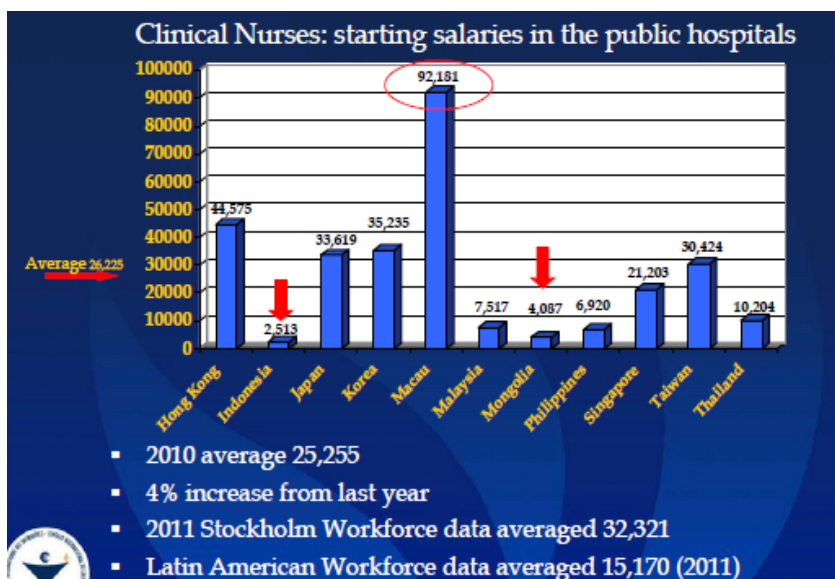

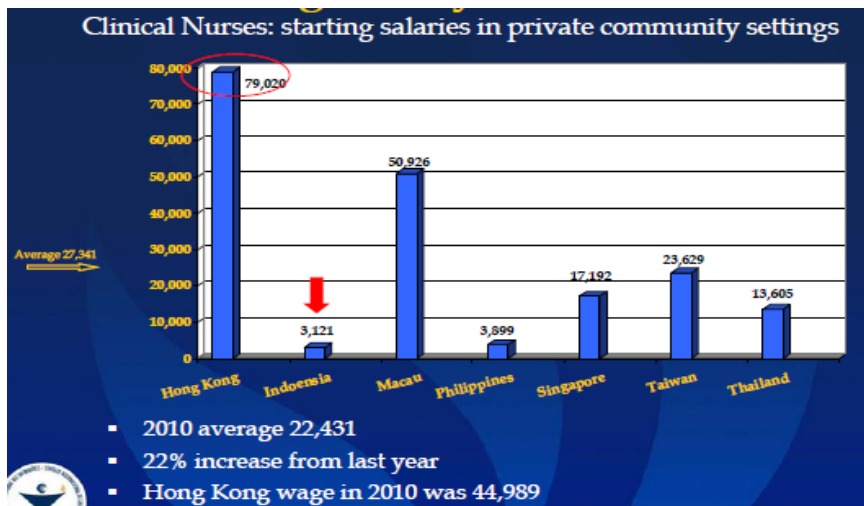
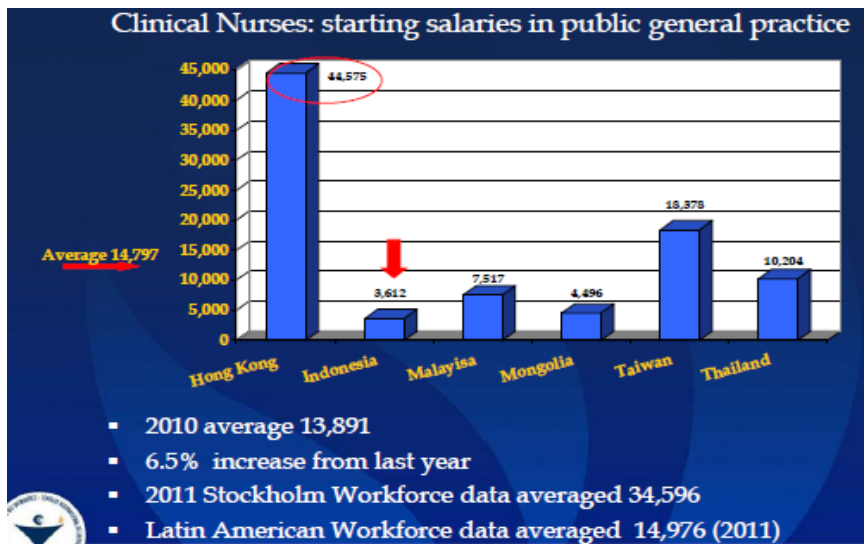
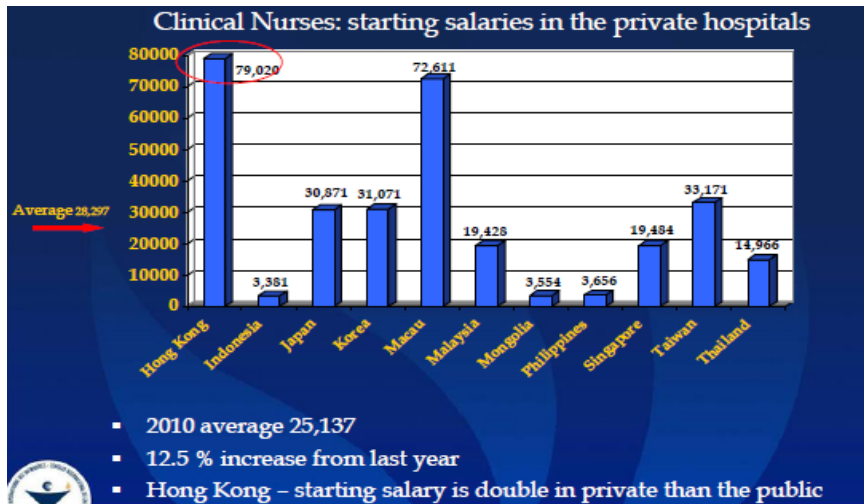

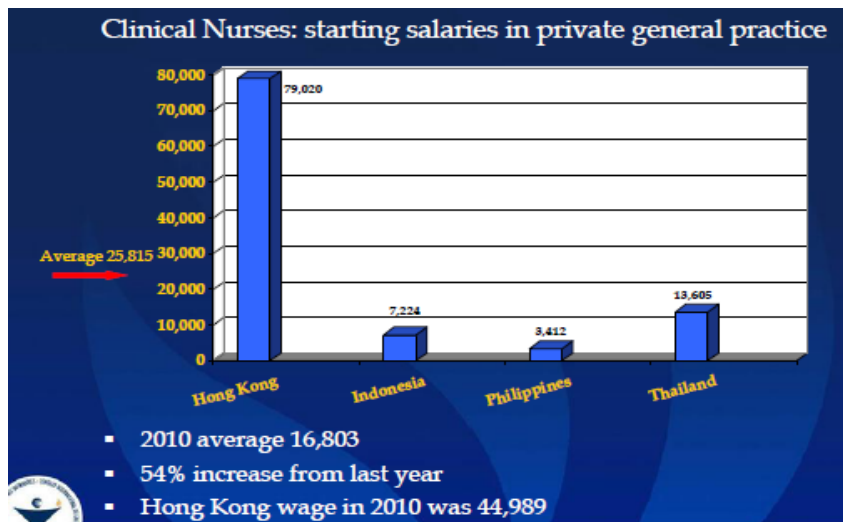
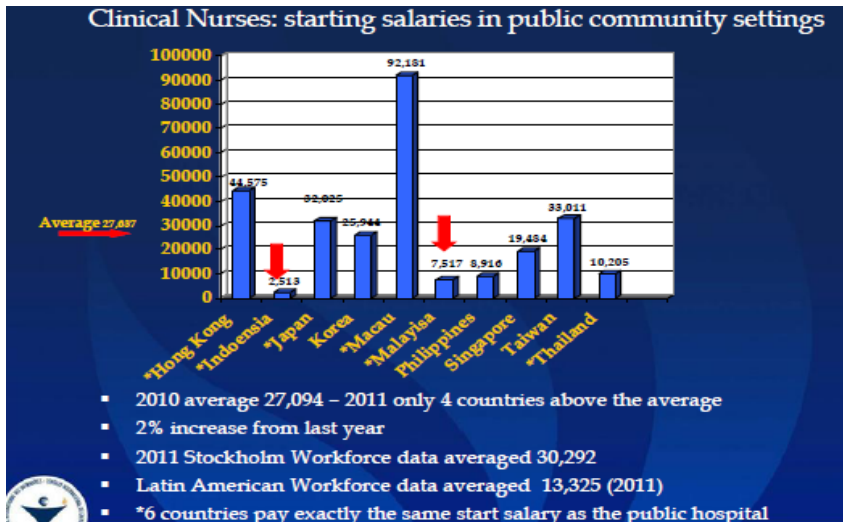

3. Comparing Salaries

Clinical Nurses: Public Hospital, Community, and General Practice

Nurse Managers: Public Hospital, Community Setting, and General Practice

Nurse Educators: Educational Institution, and Clinical Instructors



4. Number of Hours

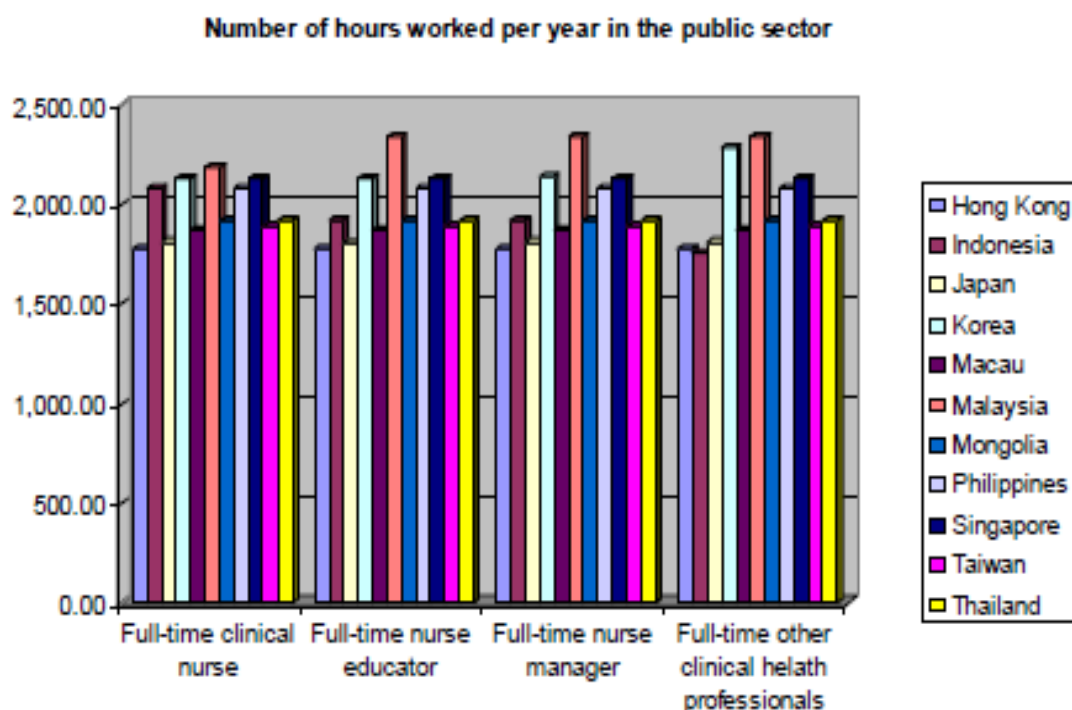

- *Macau nurses work more hours and Hong Kong fewest*
- *Nurses work the same number of hours as other health professionals*

Nursing Contribution to Health Population

1. Critical matters confronting nursing and midwifery services are nursing Workforce and Stewardship.
2. Needed: Highly motivated and competent nursing manpower/workforce with appropriate distribution and workload

How to increasing nursing contribution to health population:

1. Support the provision of quality patient care
2. Improve the motivation, productivity and performance of individuals and organization
3. Ensure the health, safety and personal well-being of staff

PPE = Quality workplaces for quality of care

PPE –Management: 1) Involve employees in planning and decision making; 2) Provide clear and comprehensive job descriptions/specifications; 3) Encourage open communication, collegiality, team work and supportive relationships; 4) Encourage the reporting of professional misconduct or violation of laws/regulations.

PPE - Support Structure: 1) Foster strong employment relationships: employer/employee/coworkers/patients; 2) Engage employees in assessment and improvement of work design and organization; 3) Promote healthy work-life balance by manageable workloads and flexible work arrangements; 4) Regularly review scope of practice and competencies.

Nurses & Nursing organizations: local, specializations, national, regional, and international organizations

Nurses for Nursing: Nursing Unity is key to power; The advancement of nursing education, nursing research must be made to improve nursing services; and “Unity is power: United we grow; Divided we fall”.

PROFESSIONAL DEVELOPMENT THROUGH NURSING REGULATIONS FOR HEALTHY POPULATION: THAI PERSPECTIVE

*Professor Wichit Srisuphan, Ph.D., R.N.
President of Thailand Nursing and Midwifery Council*

The common themes on issues of significance are the scope of practice of health profession council. There are submissions of the various health professions to the Health Professions Council (the "Council"). Certain important distinctions are the key to resolving these issues within the mandate of the Council. For Thailand Nursing and Midwifery Council (TNMC), we have a long journey on the professional development. This was initiated by the year:

1968	All health professions were regulated under the Act of Health Practice
	The regulatory body for all health profession: The Healing Art Council
1968	Medical Act approved
	Medical Council to regulate the practice of medicine
1985	Professional Nursing and Midwifery Act approved
	Nursing Council established as a regulatory body the practice of Nursing and Midwifery
1997	Revised Act Approved
1994	Dentistry Act and Pharmacy Act were established
	Dentistry Council and Pharmacy Council to regulate the practice of the professions.

2004	Medical Technology Act and Physical therapy.
	Act have been enforced, the councils were established to regulate the practices
At Present	Six Health Professional Councils have been established to regulate their own professions

Historical of Thailand Nursing and Midwifery Council (TNMC)

Thailand Nursing and Midwifery Council (TNMC) initiated by Nurses' Association of Thailand in 1968 which established under the Royal Decree of Professional Nursing and Midwifery Act BE 2528, Sept 28, 1985. And revised Act approved by the parliament dated December 23, 1997. The Act was revised in the detail as the following: 1) Definition of nursing and midwifery practice, 2) Scope of practice, 3) Increase number of committee, 4) Nurse as the president of the council, and 5) Renewal of Licenses.

“Professional Practice of Nursing” means practice of nursing to individual, family and the community in the following actions: 1) To provide education, advice, counseling, as well as solving health problems; 2) To act and assist individuals physically and mentally, including their environment, in order to solve problems of illness, alleviate symptoms, prevent dissemination of diseases and provide rehabilitation; 3) To provide treatment, as mentioned in primary medical care and immunization; 4) To collaborate with physicians to perform treatments. These actions shall be based on scientific principles and the art of nursing in performing health assessment, nursing diagnosis, planning, nursing intervention and evaluation.

“Professional Practice of Midwifery” means practice of midwifery to pregnant women, post-delivery women, their newborns and families in the following actions: 1) To provide education, advice, counseling, as well as solving health problems; 2) To act and assist pregnant women, post-delivery women, and their newborns physically and mentally, in order to prevent complications during pregnancy, delivery, and post-delivery; 3) To provide physical examinations,

delivery of the baby and family planning services; and 4) To collaborate with physicians to perform treatment.

These actions shall be based on scientific principles and the art of midwifery in performing health assessment, diagnosis, planning, intervention and evaluation. Thailand Nursing Council (TNC, 1985)

Reasons for the enactment of this Act: 1) To separate the control of the Healing Art Council this included all health professions in modern and traditional practice; 2) The number of the practitioners of nursing and midwifery has increased. It is deemed appropriate the control and set up a Nursing Council with the Committee consisting of representatives from the relevant government units as well as those who practice in the profession and have been elected as Committee Members; 3) The organization will ensure flexibility freedom and efficiency in the control and promotion of professional standards.

The Main TNC responsibilities: to regulate nurses and midwives and their practices in order to protect public and assume a high quality of services “Protecting the public right and safety through professional standards”.

The Act have been divided into 4 chapters: 1) The council: objectives, responsibilities, 2) Members, 3) Committee, and 4) Functioning of the Committees.

Objectives are: 1) To regulate the practice of registered nurses, midwives, or nurse-midwives according to the professional code of ethics; 2) To promote education, service, research and career advancement in the nursing, midwifery, or nursing and midwifery profession; 3) To promote the unity and maintain the dignity of members; 4) To assist, advise, educate, and disseminate information in relation to the scientific knowledge base of nursing, midwifery, and public health to the public and other organizations; 5) To provide consultation and recommendation to the government in relation to the advancement of nursing, midwifery, and towards the achievement of comprehensive health care; 6) To be representatives of nurses, midwives, and nurse-midwives in Thailand; and 7) To maintain justice and provide welfare to members.

Responsibilities are: 1) Register and issue the license for nurses, midwives, and nurse-midwives; 2) Suspend or revoke the license of nursing, midwifery, and nursing-midwifery; 3) Approve the nursing, midwifery, or nursing and midwifery curriculum prior to forwarding to the Ministry of Education; 4) Approve educational programs in nursing and midwifery at the certificate level; 5) Approve training programs in nursing and midwifery; 6) Accredite academic institutions that offer educational and training programs specified in 4 and 5; 7) Approve the degree, certificate equivalent to the degree, certify the certificate of specialization in nursing, midwifery or nursing and midwifery; 8) Issue a certificate of specialization of other forms of certification in nursing, midwifery, or nursing and midwifery; 9) Necessary functions in order to meet the objectives of the Nursing Council.

Members are included: Honorary membership (invited), Individual membership (170,000 members). At least 18 years old, graduated from institutes approved by the TNC with an active license, no record of misbehavior, no record of conviction by a final court judgment or a lawful order to serve an imprisonment sentence in which the committee finds threatening to the honor and reputation of the profession

Nursing Council Committee consisted of 32 members shall serve not more than 2 consecutive terms: 16 Appointed from the Government and organizations, and 16 Elected from members.

Appointed Members (Nurses)

The President of Thai Nurses' Association 5 representatives from the MOPH, 4 representatives from the MOED, 3 representatives from the M of Defense, 1 representative from the M of Interior, 1 representative from the Thai Red Cross Society, and 1 representative from the Bangkok Metropolitan

Nursing Committee Component is consisted of:

President	1 person
Vice Presidents	2 persons
Secretary-general & Vice	2 persons

Public Relations	1 person
Treasurer	1 person
Members	26 persons

Responsibilities of the committee: Administer the TNC according to objectives, Appoint sub-committee, Issue TNC regulations: 1) The attendance of at least half of its members to constitute a quorum, 2) Decision taken at a meeting shall be taken by majority vote, 3) A decision to terminate the membership due to lack of qualifications shall be taken by at least a 2/3 majority vote.

Functioning of the Committees

The Committee meeting shall require the following matters shall be approved by the special President Minister of Public Health before they are implemented: Issuing regulations, Budgeting of the Council, Terminating the membership (Lack of qualification) for a member, Making a final decision on member's conduct.

President has function in: Carry out the functions or resolution, Represent the Council, and Chair the committee meeting

Secretary - General responsibilities: To oversee the personnel of TNC, To oversee the finance and assets, To keep a register of members, and To serve as secretary of the committee.

Standing Committee: Accreditation of Nursing Institution and Recognition of curriculum, Examination for Licensure, Registration and licensing, Credentialing and Certification for Advanced Practice, Journals and Publications, Nursing Ethic and Conduct/Complaints, Professional and standards development, Nursing service development and quality assurance, National Nursing System Research Institute, International Affairs & Research supports, Financing and budgeting, Continuing Nursing/Midwifery Education and Relicensing Board, Continuing Nursing/Midwifery Education Program Evaluation and Approval, Nursing Information System, and Nurse of the year Award.

Moreover, TNC has an important role for protecting the public: Patient safety Through Quality assurance. By this role, TNC takes responsibility on

“Accreditation”. Accreditation on: Nursing educational institutions, and Nursing service in hospitals and primary care units. TNC: selected criteria for accreditation nursing education institutions by focusing on: Structure of Organization; Instructors – students ratio; Qualifications of instructors; Qualification and experience of administrators; Books, Journal in library; Information technology / computer; Curriculum composition; and Student practice / hospital, community.

In addition, the professional organization needs to be concerned on “Ethics and conducts” as following: Professional code of ethics; Rules and Regulations; Complaints of conducts / malpractice; Penalties. And responsibility on “Professional development” includes Formulate policy and planning involvement at all levels; Support the advancement of nurses at Post basic certificate, Master and Doctoral degrees; Leadership and management training; Research - evidence based practices, decision making; Career development / advancement; Planning and evaluation of nursing workforce (Adequacy, Competency, distribution and deployment, and Evaluation); Negotiation for salary, compensation and welfare; Formulate National Development Plan for NM; Propose plans of nursing development to the government.

Structure of TNC is an illustration as the following:

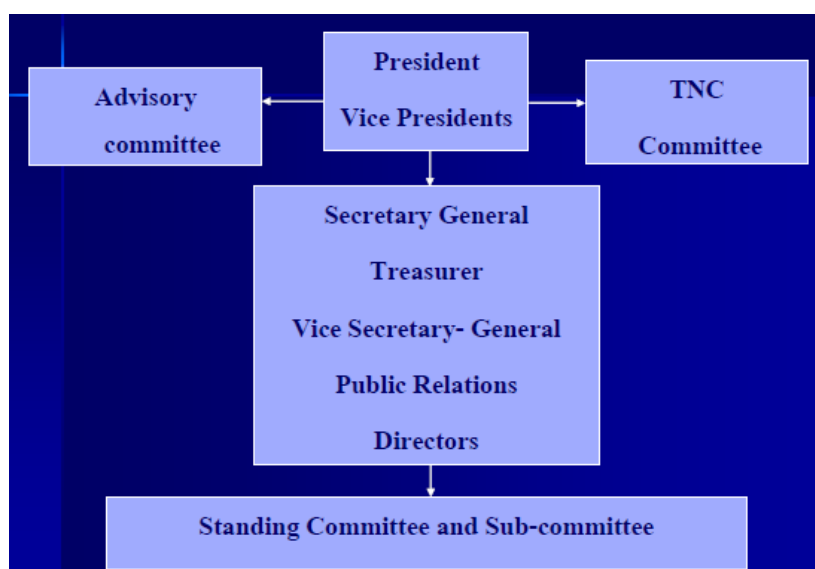

The Challenges in relation to regulatory body are:

The schools have to prepare SAR for QA at least 1 time a year, if the school receive one year of accreditation from TNMC, they have to prepare Self assessment report (SAR) twice in that year, and if the period is the same time as the ONESQA, the Organization has to prepare SAR 3 times a year since some of the criteria are not the same, This will burden nursing colleges and schools a lot.

Problems of shortage qualified nursing instructors and the existing instructors are ageing. Approximately 25% (or 1,173 persons) of 4,417 instructors are over 50 years old. Therefore we need to prepare to replace these instructors.

Shortage of registered nurses working both public and private health service. Currently, Thailand with 81 accredited nursing education institutions produce approximately 8,000 nurses in a year. Due to the expanding of health services to improve equalities of health services, especially after implementation of National Health Security Act in 2002. The shortage of nurses is estimated to be over 40,000 nurses in 2012. Therefore, the increase of production is necessary.

Qualifications of nurse-midwife instructors and research publications are under the requirements set by the Ministry of Education and National Research Council.

Some misunderstanding between the university and the Professional Council.

According to the law, the University Council has an authority to open new programs of education. However, if the new programs related to professional education, the University Council has to regulate the program according to the professional regulations. In some university may create some problems .i.e. open the new programs without accreditation from the professional council. Those who graduate from the program will not be eligible to take licensure examination.

Thailand has the policy to be medical hub of Asia.

Measures are Being Implemented to Improve the Situation

Propose the government to support the recruitment of qualified instructors, by providing fellowship and assistantships for higher education toward Ph.D. to nurses who are interested in the teaching positions and also prepare these instructors with teaching and evaluation strategies and promote the conducting of quality research and publications / dissemination of research results.

To provide information on the process to open the new nursing program for universities. The list of accredited nursing schools for students, teachers, and parent's information are provided through Medias for choices of selection to study.

Propose to increase production of nurses to lessen the shortage of nurses, and nurse-instructors as shown in Table 2 and 3.

Propose the training programs of specialization and advanced practice for nurses to support medical hub and excellent centers and quality of care for the country.

Table 2: Plan to increase production of nurses 2014-2017

Year	2015	2016	2017	2018	2019	Total
Increase students	2520	2536	2536	2536	2536	10,128

Total budget requested 4,456.32 million Baht for 10,128 students. The cabinet approved on May 14, 2013 (Table 2)

Total budget requested 5,716.8 million Baht

*To replace 1,173 aging instructors

* To increase 1,266 for teaching of 10,128 students.

Table 3: Plan to increase qualified 2,439 nurse instructors 2014-2020

Year	2014	2015	2016	2017	2018	2019	2020	Total
Person	435	435	440	445	450	180	54	2,439*

Table 4: Estimated number of qualified professional nurses 2014-2017

Categories	Number
Existing number in 2013	173,456 persons
Regular production (2014-2017) (8,000 persons/year)	32,000 persons
Increase production (2014-2017)	10,128* persons
Total professional nurses	215,584 persons

*Increased production by 53 government institutions.

- Expected number of Professional nurses during 2013-2020
Student admission
At 2017 215,584
Yearly increase 10,500
- MRA on Nursing service (December,2006 Recognition, Qualifications and Eligibility of Foreign Nurses)

1. Recognition of a Foreign Nurse

A Foreign Nurse may apply for registration or license in a host Country to be recognized and allowed to practice nursing in accordance with the laws and regulations of the Host Country concerned, subject to the following conditions:

1.1 Granted a Nursing Qualification

1.2 Possession of a valid professional registration and / or license from the Country of Origin and a current practicing license or certificate or any relevant certifying documents;

1.3 Minimum practical experience in the practice of nursing of not less than three (3) continuous years prior to the application;

1.4 Compliance with satisfactory continuing professional development in accordance with the Policy on continuing Professional Development in nursing as may be mandated by the NRA of the country of Origin;

1.5 Certification from the NRA of the Country of Origin of no record or pending investigation of having violated any technical, professional or ethical standards, local and international, for the practice of nursing ; and

1.6 Compliance with any other requirements, such as to submit for a personal medical examination or undergo an induction program or a competency assessment, as may be imposed on any such application for registration and / or licence as deemed fit by the NRA or any other relevant authority or the Government of the Host Country concerned.

2. Eligibility of Foreign Nurse

Subject to domestic laws and regulations, a Foreign Nurse who satisfies the conditions as stated in Article 3.1 is deemed eligible to work in the Host Country.

3. Undertaking of Foreign Nurse

A Foreign Nurse who is granted registration or license in the Host Country to practice nursing shall comply with following:

3.1 Local codes of professional conduct in accordance with the policy on ethics and conduct on the Practice of Nursing established and enforced by the Host Country;

3.2 Prevailing domestic laws and regulations of the Host Country, including rules and regulations governing the practice of nursing in the Host Country;

3.3 Subscribe to any requirements for an insurance liability scheme of the Host Country; and

3.4 Respect the culture and religion of the Host Country.

4. Nursing Regulatory Authority

The NRA of the Host Country shall be responsible for the following:

4.1 Evaluate the qualifications and experiences of Foreign Nurses;

4.2 Register and / or license Foreign Nurses allowing them to practice nursing in the Host Country

4.3 Monitor the professional practice and conduct of Foreign Nurses who have been registered and / or licenses; and

4.4 Ensure that Foreign Nurses observe and maintain high standards of practice of nursing in accordance with the code of professional conduct of the Host Country

NURSING EDUCATION IN BRUNEI DARUSSALAM

Hajah Salmah Hj Mohd Noor

*Lecturer (Nursing/Midwifery), PAPRSB Institute of Health Science,
Universiti Brunei Darussalam*

Introduction

Around the world, nurses have been traditionally female. Nursing Profession in Brunei Darussalam has continued to be a female-dominated profession. The nursing education in Brunei Darussalam has been through several evolutionary periods since it started in 1946 on an informal basis with no structured curriculum by the early School of Nursing. It became more structured in 1954 leading to a Trained Nurse Certificate Course. The certificate in nursing course was upgraded to the Diploma level in 1999 at the PAPRSB College of Nursing and it gained accreditation at the international level. In 2009, the Bachelor of Health Science (Nursing) Program was developed at the PAPRSB Institute of Health Sciences, University Brunei Darussalam.

The nursing education in Brunei Darussalam is designed to meet the country's prevailing health needs. It consists of the theoretical and practical training provided to the student nurses with the purpose to prepare them for their duties as nursing care professionals. It is essential to ensure that the nursing education in Brunei Darussalam is relevant to the current practice and care delivery standards.

Nursing Educational System and curricula

The education and training paradigms in nursing can be differentiated on the basis of three critical aspects of the curriculum which are highlighted as the extent forms of knowledge, nature of teacher-student relationships and the purposes or outcome of the curriculum (Ferguson,1992). Nursing Education in Brunei Darussalam started as a Hospital based Nursing Schools (Nursing and Midwifery Training Centre) and the students will be employed by the hospital while attending school thus allowing the students to gain valuable experience. The apprenticeship system/hospital based training (on the job training whereby the students are part of the staff in the rota) offered a more intense practical skills base, but emphasized the handmaiden relationship with the physician. It started in 1946 on an informal basis with no structured curriculum (Pengiran Anak Puteri Rashidah Saadatul Bolkiah College of Nursing, 2000). In 1951, a formal programme was introduced to a group of eighteen learners led by a UNICEF /WHO Nursing Sister. The learners were taught basic skills of nursing with emphasis on bedside nursing. It was a three years programme and the learners were awarded the Trained Assistant Nurse Certificate which was equivalent to the Enrolled Nurse Certificate in the United Kingdom. The School of Nursing was responsible for nursing education and the programmes were focussed on preparing the learners to provide care for the sick patients

The programmes for the training of nurses became more structured in the year 1954, and a three year and four months programme was developed leading to a certificate course known as the Trained nurse Certificate. The curriculum developed was based on the General Nursing Council Curriculum for England and Wales. However, it was modified to suit the local needs. Up to 1986, there were two levels of training programmes conducted at the School of Nursing namely, the General Nurse and the Assistant Nurse Training courses. On completion of these courses, the trainees were appointed as Trained Nurse, Junior Hospital Assistant Nurse, Junior Health Nurse and Trained Assistant Nurse. As a result of the review of curriculum, subsequently the certificate in nursing course was upgraded to

diploma level in 1999. This diploma gained accreditation at the International level. It was based at the Pengiran Anak Puteri Rashidah Sa'adatul Bolkiah College of Nursing, the one and only nursing college in Brunei Darussalam under the Ministry of Education. It was established by the gracious consent of His majesty, the Sultan and yang Di-Pertuan Negara Brunei Darussalam. The patron of the College, Her Royal Highness Princess Rashidah Sa'adatul Bolkiah declared opened the premise of the College on 4th September 1986. (Pengiran Anak Puteri Rashidah Sa'adatul Bolkiah College of Nursing,2000).

The aim of the Pengiran Anak Puteri Rashidah Sa'adatul Bolkiah, College of Nursing is to provide courses for the education and training of nurses in producing knowledgeable, analytical, reflective, competent and confident graduates committed to the pursuit of nursing excellence in Brunei Darussalam. (Pengiran Anak Puteri Rashidah Sa'adatul Bolkiah College of Nursing 2001a). Since its inception in 1986, it has provided professional nursing education in Brunei Darussalam in response to the ever increasing manpower demands of the expanding health service sector. The PAPRSB College of Nursing had initially implemented a certificate in nursing courses since its establishment but this certificate was upgraded to a Diploma in Nursing in 1991 which took three and half years to complete. Besides recruiting the local students, the college received students from abroad especially through a scholarship scheme offered to students since 1995 from Commonwealth countries and in addition in 1997 to students of ASEAN nations especially from Thailand.

The PAPRSB College of Nursing developed its own curriculum since its inception. In June 1997, a formal curriculum document with clear theoretical and clinical objectives was published. (Pengiran Anak Puteri Rashidah Saadatul Bolkiah College of Nursing, 1997). In November 2001, a newly revised curriculum was published. This new curriculum was developed following a four days workshop held in July 2000 on curriculum development led by a team of academics from the University of Wales and College of Medicine in the United Kingdom.

The PAPRSB College of Nursing has established a link with the Department of Nursing Studies, University of Wales and College of Medicine in the United Kingdom to ensure international recognition of the Diploma in Nursing Programme. Through the linkage, the students' dissertation were being examined by the external moderator of the faculty. It also act as an advisory capacity to ensure the training enable the students to achieve high level of performance, expertist, knowledge and competence as identified in the Nursing and Midwifery Council for Nursing, Midwifery and Health Visiting in the United Kingdom.

The Diploma in Nursing is designed to prepare the students to become professional nurses and enable them to function in the hospital and community clinics. The curriculum consists of 805 hours in each semester and the programme is conducted over seven semesters with an equal proportion of integration in nursing theory and nursing practicum. The emphasis of the curriculum is on a wide range of scientific knowledge. In the first semester, the subjects taught are anatomy and physiology, psychology, pharmacology, nutrition, nursing and health. This scientific knowledge was meant to equip the student nurses the basics of human body functions and medical needs that are central to clients care and the nursing practice. The third and fourth semesters focused on Nursing and Health, research, transcultural nursing, legal and ethical issues, Islamic religious knowledge and nursing skills. The subjects on the specialised aspects of nursing were introduced in the fifth and sixth semesters which comprised of paediatric nursing, trauma nursing, mental health nursing, occupational health nursing, community health nursing, operating theatre nursing and management. All the subjects mentioned made up 50% of the theoretical input of the curriculum and the 50% were the practicum.

The National Ideology of Malay Islam Monarchy (MIB) to promote peace, stability, discipline and national identity was incorporated in the curriculum of Diploma in nursing to enhance the professional role of nurses in Brunei Darussalam. In August 2009 the nusing education marks another milestone and by the Titah of His Majesty Sultan yang di Pertuan Negara Brunei Darussalam, the

PAPRSB College of Nursing has been upgraded to a University level at the PAPRSB Institute of Health Sciences, University Brunei Darussalam. The University Brunei Darussalam was established on 28th October 1985, opening its door to the first intake of 176 students. Today, the University accommodates over 600 staff and 4,000 students with a vision of “A first class international university and a distinctive national identity. The University Brunei Darussalam’s mission is “to develop the individual and society as a whole through the cultivation and enrichment of the intellect, faith and culture accomplished through the creation of a conducive environment for achieving excellence in teaching, learning, research, scholarship, public services and professional practices.” The academic faculties and centres are Academy of Brunei Studies, Faculty of Arts and Social Sciences, Faculty of Business, Economics and Policy Studies, Faculty of Science, Sultan Hassanal Bolkiah Institute of Education, Pengiran Anak Puteri Rashidah Sa’adatul Bolkiah (PAPRSB) Institute of Health Sciences, Institute of Asian Studies, Sultan Omar’Ali Saifuddien Centre for Islamic Studies, Language Centre and Continuing Education Centre.

The nursing education is located at the PAPRSB Institute of Health Sciences which was formerly known as Institute of Medicine and it offers the undergraduate program for Bachelor of Health Sciences majoring in Medicine, Biomedical sciences, Nursing, Midwifery and postgraduate programs. The undergraduate programs in Nursing and Midwifery were introduced in August 2009 and it recruited 8 students for the first cohort and it has increased to 35 students for the Bachelor of Health Science in Nursing in 2013 including international students.

The Bachelor of Health Science (Nursing & Midwifery) consists of 128 modular credits in total over four years and aim to develop lifelong learners who can adapt effectively to changes in both the theory and practice of nursing. It opens up opportunities for greater career advancement and higher salary options It follows the University Brunei Darussalam GenNEXT education framework consisting of core and breadth modules and is designed for the students to excel

according to their individual learning styles. It ensures that the students emerge from the University Darussalam with a high quality education that is centred for their individual needs as well as the needs of the constant changing world environment. The breadth modules offer the students an opportunity to explore their interests outside their chosen academic discipline and allowing them to develop as well-rounded students. Although the national language in Brunei Darussalam is Malay (Bahasa Melayu, the medium of instruction for all the programs is in English language.

The first Year of the Bachelor of Health Science (Nursing & Midwifery) highlighted the Problem Based Learning pedagogy and is incorporated in the Chemistry of Life and Body Structure and Function modules in the Common Foundation Year. The third year of the program is termed a Discovery year in which the students may undertake a Study Abroad Program (SAP) or internship program. The Study Abroad Program is based upon the students 'grade point average and is offered to those students who achieve the benchmark grade point average and it enables the best students to go abroad for a semester or two semesters to participate in another university program or clinical placement opportunity. The PAPRSB Institute of Health Sciences has sent students to Queens University, Belfast and Universiti Putra Malaysia for their Discovery Year in 2012.

The team of academics from Monash School of Nursing and Midwifery, Australia has been invited in December 2009 for a five days consultancy visit related to curriculum validation, development and implementation of the Bachelor of Health Science (Nursing & Midwifery) and also to build a longer term goal orientated academic and research relationships. Prior to their visit several curriculum documents were sent over to Monash School of Nursing and Midwifery, reviewed and compared against the standards for accreditation of University courses set by the Nurses Board of Victoria (2007) as a baseline for identifying areas for improvement within the course curricula. The review of all these documents enabled the team to identify key factors that required more in-

depth evaluation and clarification for benchmarking with international curricula to occur. A number of important outcomes were achieved during the site visit. Curriculum discussion and facilitation workshops were conducted over a four day period, site visits to the hospital and health services were made. Recommendations were made on curriculum documents, clinical model, teaching and learning resources and workforce development.

Besides the Bachelor of Health Science (Nursing & Midwifery) programs, the PAPRSB Institute of Health Sciences offer the PhD in Health Science, (Nursing), Master in Health Science (Nursing), Diploma in Health Science (Nursing, Midwifery and Paramedic). The Advanced Diploma is a 12 months program that graduates of the Diploma program undertake to extend their knowledge and clinical practice in a speciality area of choice such as Advanced Diploma in Mental Health Nursing, Paediatric Nursing, Emergency Nursing, Cardiac Nursing, Critical Care Nursing, Midwifery which caters to the demands of the workforce development for the Registered nurses in the Ministry of Health who do not meet the criteria for the Bachelor of Health Science (Nursing & Midwifery).

An important concept of the Bachelor of Health Science (Nursing & Midwifery) curriculum is the need for the students to be exposed to the clinical placement early in their programme of studies. Since nursing is a practice discipline, experiential learning through clinical practice is vital in nursing education. Within the structure of the clinical placement practicum, the students are inducted in to the profession of nursing. The aim being to prepare the students to acquire competencies, develop confidence and right attitude so that at the end of the training they are able to deliver high quality nursing care to the clients. The conceptual framework of the clinical practice is based on the development from a novice to a competent practitioner. The duration of the clinical practice is increased as the semester progresses. The students enrolled in the Diploma in Health Science (Nursing, Midwifery and Paramedic) and Bachelor of Health Science (Nursing & Midwifery) are granted supernumerary status similar to other

students in higher education in Brunei Darussalam. Given the privilege of the supernumerary status, they are not included in the work schedule as members of the staff in the clinical placement during their training. Therefore, these provide opportunities for learning in the clinical placement in reducing the burden of the workload and enable the students to achieve the clinical objectives at the end of their training.

Qualifications of nurse educators (current and expected)

Majority of the academic staff have migrated from the PAPRSB College of Nursing to the PAPRSB Institute of Health Sciences, University Brunei Darussalam since July 2010. The Academic staff for the Bachelor of Health Science (Nursing & Midwifery) is predominantly female and 99% are Bruneians. There are 34 academic staff, majority are qualified at Masters Level, 5 were awarded the Brunei Government Scholarship for their PhD abroad. There are no Associate Professors or professors of Nursing or Midwifery employed at this stage. However the PAPRSB Institute of Health Sciences will be expecting an eminent visiting Professor from other countries.

Research development

The University Brunei Darussalam has several thriving research centres open to collaboration and partnership with world class universities. There are five centres focusing in research development namely the Sultan Omar 'Ali Saifuddien Centre for Islamic Studies, Kuala Belalong Field Studies Centre, Institute of Asian Studies, UBD/IBM Centre and eGovernment Centre. At the PAPRSB Institute of Health Sciences, the Global Health Research Cluster started in 2012 which encompassed other research clusters such as cancer, ageing, obesity, youth and occupational health.

Challenges of AEC for nursing education in Brunei Darussalam.

Brunei Darussalam has a population of about 400,000 and the nursing education offered at the PAPRSB Institute of Health Sciences Universiti Brunei Darussalam has made a remarkable progress since it started in August 2009 with an increasing number of the recruitment of students every year under the Brunei Government Scholarships for the local students. To practice as a Registered Nurse in the Ministry of Health Brunei Darussalam, upon completion of their nursing education, the graduates have to be registered with the Brunei Board of Nursing. All programs run by the PAPRSB Institute of Health Sciences have to be submitted to the Senate for approval and accreditation prior to the commencement of the programs.

One of the challenges that the PAPRSB Institute of Health Sciences encountered is not producing adequate number of graduates and diplomas to meet the demands of the workforce in the Ministry of Health. In order to meet the demands of the health care services, the Ministry of Health is still recruiting foreign registered nurses from other countries. It is important that the standard of the Nursing education within the PAPRSB Institute of Health Sciences has to be a quality education and marketable internationally. Together with the nurse educators, curriculum needs to be transformed to meet the international markets.

NURSING SERVICES IN BRUNEI DARUSSALAM

HJH Ramlah Binti Kisut

Senior Staff Nurse (Community Health),

RN. Dip. Nursing, Cert. Midwifery, Dip. Community Health Nursing,

Bachelor of Nursing

Abstract

Nursing services in Brunei Darussalam strive to provide a comprehensive health care services for all through excellent nursing services in supporting the Ministry of Health Vision 2035: Together Towards A Healthy Nation. The Department of Nursing Services establish, maintain and monitor standard guidelines for the nursing and midwifery profession, in areas of practice encompassing clinical management, education and research in order to ensure efficient and high quality care services. The department has made a remarkable progress in term of education and qualification of its nursing manpower as evidenced from the increasing number of nurses with higher qualifications such as Bachelor and Master Degree in various nursing specialties. In area of research development the Department of Nursing Services has set up the Nursing Monitoring and Quality Control Unit to monitor standard of practice within the Department of Nursing Services.

Introduction

Ministry of health is the main agency responsible for direct or indirect delivery of health care, health care information and health care-related services in Brunei Darussalam and is headed by the Minister of Health (Ministry of Health website: www.moh.gov.bn). The organization consists of three major groups of service provider:

- 1) Ministry proper/Central
- 2) The Public Health Services
- 3) The Medical Services

Nursing Services is one of the service providers under the Medical Services which is headed by the Director of Nursing Services.

Nurses and midwives make up the largest health care work force in this country. Nurses and midwives also spend the greatest amount of time in delivering patient care as a profession. Nurses and midwives therefore have valuable insights and unique abilities to contribute as partners with other health care professionals in improving the quality of care and service excellence as envisioned in the Ministry of Health vision 2035 : Together Towards A Healthy Nation.

Health Care Delivery System

The government of Brunei Darussalam provides free medical and health care to all the citizens. The delivery of health care services is provided through two main areas; the Department of Medical Services and the Department of Health Services (Health Information Booklet, 2011). At present, there are four (4) government hospitals i.e one in each districts, sixteen (16) Health Centres, twenty-three (23) Maternal and Child Health Clinics (MCHC), five (5) travelling clinics, and two (2) flying Medical Services to remote areas that are not accessible or difficult to access by land or water.

As an effort towards strengthening health care system in the country, the Ministry of Health has developed new strategy 'Vision 2035:

Ministry of Health Strategy’ in line with ‘Wawasan Brunei 2035’ (Ministry of Health, 2008). Under the vision 2035: **“Together Towards A Healthy Nation”**, five strategic themes are emphasized focusing on:

- Comprehensive healthcare system that emphasizes service excellence
- A nation that embraces and practices healthy lifestyle
- Sustainability through resource optimization, innovation and excellence
- Effective policies and regulations that ensure protection for all
- Transparent and proactive governance

Nursing and Midwifery care in Brunei Darussalam is changing rapidly, with increasing patient expectations and demand for care. Nurses including midwives, Nurse Paramedic, Dental Nurses and Community Health Nurses are expanding their roles and responsibilities in line with the increasingly complex and rapid development in health care system.

Health Care Needs and Nursing Needs

In line with the Ministry of Health vision 2035, the Nursing Services Department plays a major role in providing a comprehensive health care services for all through excellent nursing services. This includes:

Recruitment and deployment of nursing manpower which provides support services and forms the largest group of healthcare workforce in the Ministry of Health.

Establishing policies and standard guidelines for the nursing and midwifery profession, in areas of practice encompassing clinical management, education and research to ensure efficient and high quality care services in supporting the Ministry of Health Vision 2035.

Professional Development which has been acknowledged as vital in updating nursing and midwifery practice towards reinforcing professional standards in influencing effective, safe and quality patient care. Opportunities are provided for nurses and midwives to attend continuing educational programs

locally and abroad, in the form of training, refresher courses, seminars/ conferences and workshops.

Enhancing nursing and midwifery health promotion activities.

Establishing a Unit for continuing nursing and midwifery education which is supportive of the mission that promotes educational activities in strengthening the quality of nursing and midwifery care.

Providing a second level training in Assistant Nurse and Midwifery Courses, to meet the workforce requirement in the Ministry of Health.

Monitoring the nursing and midwifery practices which should be evidence- based and abreast with current best practices.

Nursing Manpower

The total number of nursing manpower as of December 2012 is 2257. which forms the largest group of healthcare workforce in the Ministry of Health. Distribution and deployment of nursing manpower is arranged according to the needs and requirement of services in both hospitals and community setting.

Level of Nursing Manpower

Nursing staff within the Department of Nursing Services, Ministry of Health comprises of: Director of Nursing Services, Principal Nursing Officer, Senior Nursing Officer, Nursing Officer, Senior Staff Nurse, Staff Nurse, Senior Assistant Nurse/ Midwife, Special Grade Assistant Nurse /Midwife, and Assistant Nurse/ Midwife.

Qualification

Department of Nursing Services recruited local nurses with different level of nursing education either from local nursing institution or abroad. Majority of the nursing manpower obtain basic nursing qualification locally. After few years of working experience the nurses are encouraged to upgrade their knowledge and qualifications by undergoing Post-Basic / Post Registration training programs

at Certificate, Diploma, Advanced Diploma and higher qualification at Degree and Masters Level in various nursing specialties such as: Accident and Emergency Nursing, Cardiac Nursing, Intensive Care nursing, Operating Theatre Nursing, Paediatric Nursing, Community Health Nursing, Midwifery, Ophthalmic Nursing, Oncology Nursing, Infection Control, Nephrology Nursing, Orthopaedic Nursing, and Nursing Eductaion and Etc.

Post-Basic / Post Registration and higher qualifications are obtained from local as well as international institution such as Singapore, Malaysia, United Kingdom, Germany and Australia. Another important milestone in the Department of Nursing Services in Brunei Darussalam is the increase number of nurses with higher qualification such as Bachelor and Master Degree. The proportion of nurses with Bachelor Degrees is increasing as shown in figure 1.

Figure 1. Number of Nurses Undertaking Bachelor Degree under Government In-Service Scheme

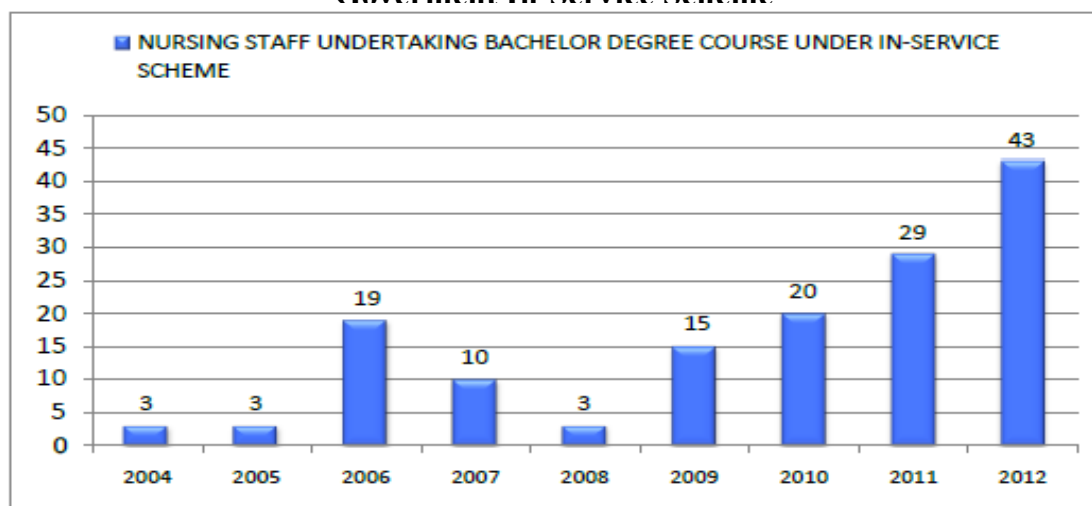

Summary of the Nursing staff qualifications can be outlined as follows:

Basic Nursing Qualification:

- Assistant Nurse Level: Assistant Nurse Certificate (Nursing/Midwifery)
- Staff Nurse Level: Certificate in Nursing, Diploma in Nursing
- Post Basic /Post registration Qualification: Certificate, Diploma, Advanced Diploma
- Higher Qualification: Bachelor degree, Master Degree

Demand and Supply of Nursing Manpower

Most of the nursing manpower is locals which make up 94% of the nursing workforce. Recruitment of nurses and midwives is mostly from the Institute of Health Sciences, University of Brunei Darussalam (UBD). The Department of Nursing services also recruit expatriate nurses from abroad to accommodate the increase demand and expansion of services.

Licensing

Nursing Board for Brunei is a Regulatory Body established under the Nurses Registration Act and Midwives Act as stipulated in the Laws of Brunei that governs and regulate the practice of nursing and midwifery in Brunei Darussalam. The Board came into force in 1988. (<http://www.moh.gov.bn/bruneinursingboard>)

The Board is empowered by the Laws of Brunei Darussalam which can be accessed and downloaded from the Attorney General's Chambers, Brunei Darussalam website at www.agc.gov.bn.

Establishment & Constitution of the Board: 'Nurses Registration' Chapter 140, cited as Nurses Registration Act 1961, and 'Midwives' Chapter 139, cited as Midwives Act 1955.

Functions of the board: 1) To regulate the Standards and scope of nursing and midwifery practice in Brunei Darussalam; and Standards of training and education for nurses and midwives; 2) To establish, maintain and develop acceptable standards of: Knowledge, skills and competencies among its members; Qualifications and practice for the practice of nursing and midwifery; 3) To approve or reject applications for registration of nurses and midwives; 4) To review/re-consider re-registration of nurses and midwives; 5) To issue practicing certificates.

The Nursing Board for Brunei is also an active participant of ASEAN Joint Coordinating Committee of Nursing (AJCCN) since the Mutual Recognition Arrangement (MRA) in Nursing Services was signed in 2006.

Nursing Staff Development

Nursing Services Department continually upgrade core competencies to ensure professionalism and ethical standard by means of continuous professional development. Continuing Professional Development (CPD) for registered nurses and midwives are monitored through the implementation of Continuing Nursing & Midwifery Education (CNME) record booklet under the purview of the Department of Nursing Services, Ministry of Health. All categories of nurses and midwives are required to achieve a minimum of 30 CNME points annually through attending various nursing and midwifery educational activities as part of the requirement for renewal of practicing certificate.

Staff development program conducted by the Department of Nursing Services include structured courses: Assistant Nurse Training [Nursing/Midwifery], and Advanced Diploma in Health Services Management.

Whereas other in-house staff development programs include short courses such as: Refresher Courses (Midwifery, Community Health, Pediatric, Endocrinology, Psychiatric), ECG Workshop, Renal In-House Training, 20-Hour Breastfeeding Course, Advanced Emergency Nursing Course, Coronary Care Nursing Course, Operating Theatre Nursing Update Course, Critical Care Nursing Course, Pain Management Course, Infection Control Link Nurse Course, Ward Management & Leadership Course, and Frontline Nurse Manager Course.

Nurses and midwives are also given the opportunity to go abroad to attend conferences, symposium, workshop, seminar and clinical working attachment to broaden their nursing knowledge as well as to enhance and advancing their clinical skills.

Research Development

The Department of Nursing Services has set up the Quality Control Unit to look into research activity and audit within the department of nursing services as well as to assist nurses in the development of research study and clinical audit in their respective clinical setting.

Challenges of ASEAN Economic Community (AEC) for Department of Nursing Services in Brunei

As one of the members of the ASEAN countries require Nursing Services in Brunei to prepare to develop nursing system applicable to both local and ASEAN population in order to enter AEC 2015. Few challenges that need to be addressed are: Nursing manpower shortage (Development and expansion of services, Retention and recruitment of nursing manpower)

Conclusion

In supporting ASEAN Economic Community (AEC) 2015, the Department of Nursing Services, Brunei Darussalam will continually upgrade nursing education and services in order to promote common core competencies among nursing and midwifery profession in ASEAN countries. Nursing Services in Brunei also strive to contribute as partners with other ASEAN members to enhance nursing education and nursing services for healthy ASEAN population.

Acknowledgements:

- Acting Director of Nursing Services, Department of Nursing Services, Ministry of Health, Negara Brunei Darussalam
- Nursing Board for Brunei, Department of Nursing Services, Ministry of Health, Negara Brunei Darussalam
- Nursing Training and Development Centre, Department of Nursing Services, Ministry of Health.

References

- Continuing Nursing & Midwifery Education (CNME) record booklet (2010).
Department of Nursing Services, Ministry of Health.
- Health Information Booklet. (2011). Ministry of Health. Retrieved June 20, 2013,
from www.moh.gov.bn
- Ministry of Health website www.moh.gov.bn
- Ministry of Health (2008). “Together Towards A Healthy Nation”. Vision 2035:
Ministry of Health Strategy. Ministry of Health, Brunei Darussalam.
- Nursing Board for Brunei, Ministry of Health website. Retrieved June 20, 2013,
from www.moh.gov.bn/bruneinursingboard.

6

NURSING EDUCATION IN CAMBODIA

Virya Koy, RN, MNSc., MHPEd.

*Chief Bureau of Nursing and Midwifery, Hospital Services Department,
Ministry of Health. President of Cambodian Council of Nurses.*

Email: viryakoy@yahoo.com

Abstract

Nursing education in Cambodia is characterized with progress in responding to societal needs of the country. Even though there was decades of civil war devastated Cambodian society. However, it is taken high responsibility to produce competent professional nurses to fulfill the tasks at the clinical sites.

There are two ministerial authorities as Ministry of Health and Ministry of Education and Youth, which manage both public and private universities. The existing programs are primary nurse and midwife; associate degree in nursing and midwifery; and Bachelor of Science in nursing and midwifery.

Problems in matching nurse educators of supplies and demands are found through the country. There are many medical doctors who are still teaching nursing students. Again, most of nursing educators are associate degree in nursing preparation.

Given the nursing education challenges in the context of Asian Economic Community includes lack of higher education faculty, laws, regulations, and cultures.

Introduction

Decades of civil war devastated Cambodian society – its infrastructure, education and particularly the health system. Many health professionals and other intellectuals were murdered or forced from the country, and health professional schools were closed. While health services delivery has been improved, resulting in improved health care for the rural poor and the most vulnerable, with some of the worst human development indicators in South East Asia.

It is the responsibility of all nursing educators and leaders to shape nursing education to produce qualified nurse educators in order to produce nurse leaders and practitioners of tomorrow. Through carefully determined pedagogy and curriculum, nurse educators can engage students in important ways: ways that will fully prepare students to shape and partake in the emerging primary health care system, a system founded on respect, understanding and a keen awareness of the social determinants of health. A system that will rely on nurses that know how to effectively lead change, and truly promote health, healing, and wellness in the diverse populations we serve.

History of Nursing Education in Cambodia

Cambodian has a long history of nursing education since 1950. Recognizing the importance of good nursing care to a patient's well-being, physicians initiated courses for those interested in nursing.

The history of nursing is intertwined with the history of nursing education and nursing's quest for a professional identity. (Allen, 2006) Education has been vital in providing the knowledge, skills, and ability to give quality care to our patients, elevating nursing to a profession and gaining the respect of other professions (Borsay, 2009). Physicians, while recognizing the need for nursing care feared that if nurses were given too much education the nurse would supplant them. These were challenges that nurses needed to overcome; given the enormous challenge, slowly nurses have risen to the challenges thus the profession of nursing was built.

This nursing educational history encourages understanding in defining our professional identity in Cambodia. As such, it is relevant to current nursing practice. In so doing, we will give them a sense of professional identity, a useful methodological research skill, and a context for evaluating information.

Table 1. Historical events in nursing (milestones in the development of nursing (Bureau of Nursing and Midwifery, 2008)

Year	Description of education
1950	A. First Nursing School was founded 2 years General Nursing Course was commenced
1960	- Nursing training Curriculum was expanded to be a 3-year diploma program
1975	1. Nursing school closed down by “Khmer Rouge regime”
1979	2. Primary Nursing started 3. Primary midwife course commenced
1980	1. 3-year program for secondary Nurses and midwifery started
Year	Description of education
1983	1. 2-year bridge course for primary nurse to secondary Nurses started
1989	1. 1- year Primary Nurse and Primary Midwife program were started
1991	• 2- year Anesthesiology course was introduced, closed 1999. • 1-year Dental Nursing Course
1994	1. New 3-year nursing curriculum for secondary Nurse started 2. New 3-year midwifery curriculum for secondary midwives started
1995	3. 3+1-year secondary Nurse and midwife curriculum started.
1997	4. 2-year bridge course from primary to secondary nurse and midwife
1998	1. New nursing curriculum revised for ADN. 2. 1-year program of Basic Eye Nurse started
1999	1. 1.5-year psychiatric/Mental Health nursing course was commenced
2003	2. 1 year program for nurse manager, closed 2006
2008	1. Curriculum of Bachelor of Science in Nursing 4-year program
2013	1. Bridging course from ADN to BSN (2-year program) started.
February	

Nursing educational system and curriculum:

Nursing educational system

The nursing educational institutions are under the Ministry of Health for public nursing school and under Ministry of Education and Youth for the private nursing schools and military school. Since 1950 until 1975, there was only one nursing school around Cambodia. After 1979 the Khmer Rouge Regime collapsed and the new government started the improvement of infrastructures and education systems. Nursing education was the one, which the new government concentrated on and opened. By 1996, approximately 4 regional nursing schools were in operation in the country. These programs followed a fairly typical pattern. Each nursing school was either affiliated with or owned by a physician. Students received two to three years of training. While in the program students carried out the majority of patient care activities offered in the hospital, receiving only a modicum of classroom education in the form of lectures on patient care and related subjects. At the end of the educational program, students received a diploma and were eligible to seek work as a trained nurse.

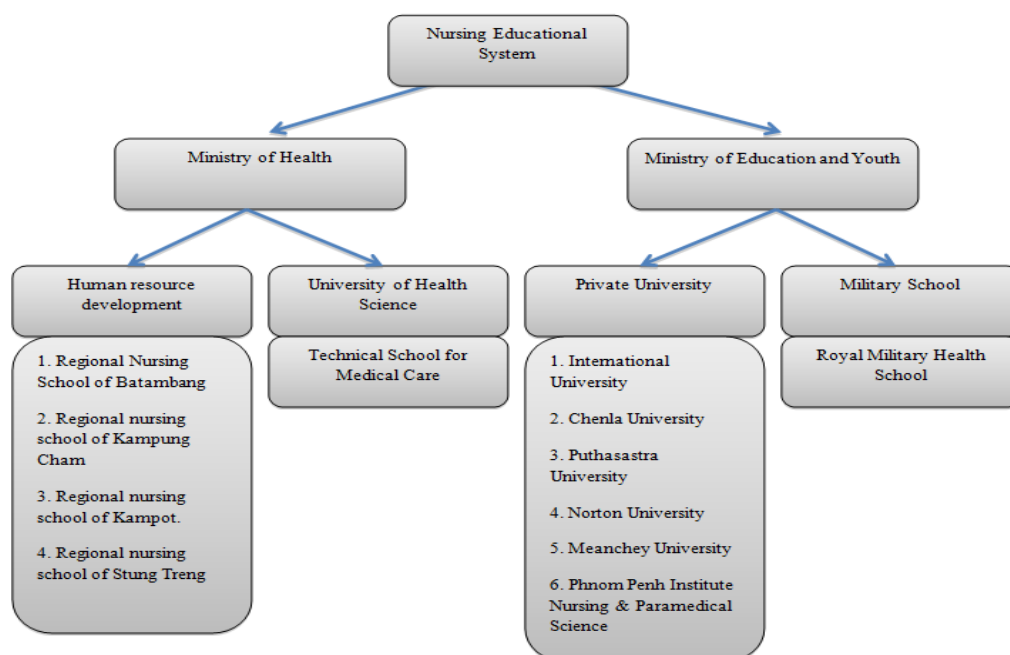

Figure 1: Nursing Education System

Curriculum

Three types of nursing programs prepare students such as primary nurse, associate (ADN), and baccalaureate (BSN). In addition, BSN is divided into 2 programs: (1) student hold diploma of general school, they take national entry exam to study 4-year program, (2) ADN's graduates take national entry exam to enroll for 2-year program. Although, primary nursing program is not mandated to do national exit exam and registration. However, ADN and BSN are mandated to do national exit exam and register for getting license to practice.

On the other hand, Ministry of Health designed nursing educational framework for the higher education in Cambodia. This framework will prepare nurses from BSN to MNS and to PhD program.

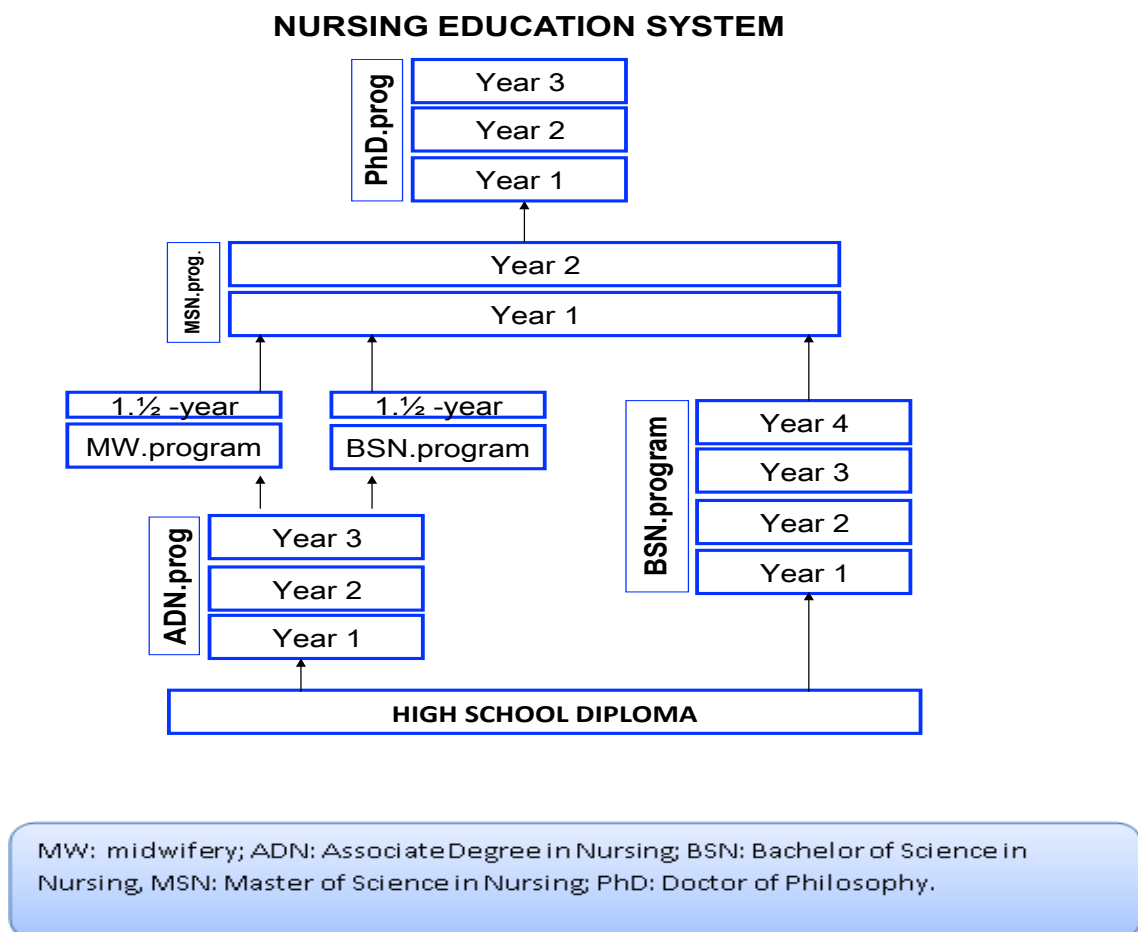

Figure 2: Nursing Educational Roadmap (Joint Ministry of Health and Education and Youth, 2007)

Primary nursing program: (Sub Decree, 2007)

This program is offered 1-year academic program. The students require having diploma of general education. After 2 years of graduation, primary nurse can continue to associate degree in nursing program. The graduates of this program must continue in second year of ADN.

Associate degree in nursing program:

Government and private universities offer associate degree in nursing programs, designed to be completed in three academic years by a full-time student whom has diploma of general education as required (Figure 4 & 5).

Table 2: ADN Curriculum (MOH, 2007)

7. ADN Program Total Credits Hours

Year	Theory (T)		Class Practice	Practice (P)		Field study Internship (*)		Total by Year	
	Cr	Hr	Hr	Cr	Hr	Cr	Hr	Cr	Hr
I	36	539	91	4	180			40	810
II	33	503	52	5	225	1*	90	38+1*	870
III	20	316	104	3	135	6*	540	23+6*	1095
Total	89	1358	247	12	540	7*	630	101+7*	2775

Note:

- DN Program Total Credits = 108 Credits (Included *Credits)
- DN Program Total Hours = 2775 hours (Included *Credits)
 - Theory = 1358 Hr = 48.90%
 - Practice = 1417 Hr = 51.10%

Bachelor of Science in Nursing

The baccalaureate degree program in nursing prepares students for entry level positions in professional nursing practice. This program is completed in 4 academic years full-time, for those who have a diploma of general school as required. Graduates are able to provide nursing care to individuals of all ages and families from diverse cultural backgrounds in any setting offering health care services. Health promotion, health maintenance, disease prevention and teaching are emphasized in all clinical settings. In addition, careful attention is paid to the

skills needed in the treatment of the acutely ill, geriatric populations, and populations at risk.

8. Clinical requirements for ADN Students

No	Nursing Procedures	S2	S3	S4	S5	# Requirement	
						Observe	Perform
	Fundamental nursing I, II						
1	Sterile gloving	x					10
2	Measuring body temperature	x					20
3	Assessing radial pulse	x					20
4	Assessing respirations	x					20
5	Assessing arterial blood pressure	x					20
6	Risk assessment, skin assessment, and prevention strategies of pressure ulcer	x					5
7	Administering intra dermal injections		x				10
8	Administering subcutaneous injections		x				10
9	Administering intramuscular injections		x				20
10	Initiating intravenous therapy		x				20
11	Initiating Blood therapy				x		
12	Monitoring for adverse reactions to transfusion				x		5
13	Applying a wet to dry dressing			x			10
14	Preparing the client for surgery			x			
15	Performing postoperative care of the surgical client			x			5

No	Adult nursing methodology I, II, & III					
1	Care of the client in skeletal traction and pin site care				x	5
2	Performing oro pharyngeal suctioning			x		5
3	Applying nasal cannula or oxygen mask			x		10
4	Caring for clients with chest tube connected to disposal drainage system				x	5
5	Intubating the client with a naso gastric feeding tube			x		5
6	Inserting a indwelling catheter			x		10
7	Performing wound suture				x	5
8	Performing suture removal			x		10
9	Performing Abscess incision				x	5
24						

Figure 3: Clinical Practice Requirements for AND

Demands & supply of nurse educators, nursing school

Problems in matching nurse educators of supply and demand are found throughout the country. Recruitment of nurse educators and their retention, is particularly difficult due to poor salaries, lack of incentives, isolation and poor working conditions. In Cambodia, we need to recruit qualified nurse educators, retention, and promote to higher education.

- In spite of the attention paid to the national nursing shortage, relatively little attention has been given to a related shortage, that of faculty to teach nursing.
- Student recruitment and retention efforts have been shown to be very effective, but successful recruitment is only one part of the solution. Nursing programs must have “seats” for applicants or face the potential of losing them in spite of recruitment efforts.
- To resolve the dilemma, it will be necessary to reestablish a balance between the supply and demand for nursing education resources.

Qualification of Nurse Educators (Current & Expected):

In the current situation, mostly our nurse educators are ADN preparation. Nurse educators are registered nurses with advanced education who are also teachers. There are two different types of faculty who taught at every nursing school, most faculty members work part-time but there is only the government nursing school there are more full-time faculty jobs. Most nurse educators have extensive clinical experience, and many continue caring for patients after becoming educators, especially those working part-time.. This means nurse educators are always on the “leading edge” of clinical practice. With experience, nurse educators may advance to administrative roles, managing nurse education programs, writing or reviewing textbooks, and developing continuing education programs for working nurses.

In addition, as the Ministry of Health (2001) mentioned that nurse educator must have higher degree than the class that they taught. In this regard, nurse educator is at least Bachelor of Science in nursing for associate degree in nursing program. Moreover, this is also mentioned that it should have master preparation to teach bachelor program.

In sum, in the near future, master of nursing science preparation must obtain to meet Ministry of Health requirement. Furthermore, if we can have some

Doctor of Philosophy will help, organize, and prepare other nurses to move to a higher level.

8. BSN Program Total Credits Hours

Year	Theory (T)		Class Practice	Practice (P)		Field study Internship (*)		Total by Year	
	Cr	Hr	Hr	Cr	Hr	Cr	Hr	Cr	Hr
FY**	30	510						30	510
II	33	503	157	6	270			39	930
III	35	546	204	6	270	2*	180	41+2*	1200
IV	16	243	12	4	180	8*	720	20+8*	1155
Total	84	1292	373	16	720	10*	900	100+10*	3285
Total**	114	1802	373	16	720	10*	900	130+10*	3795

Note:

1- BSN program without FY :

- BSN Program Total Credits = 110 Credits (*Credits included)
- BSN Program Total Hours = 3285 hours (*Credits Included)
- Theory = 1292 Hr = 39.33 %
- Practice = 1993 Hr = 60.67 %

2- BSN program with FY :

- BSN Program Total Credits (FY Included) = 140 Credits (*Credits included)
- BSN Program Total Hours (FY Included) = 3795 hours (*Credits Included)
- Theory = 1802 Hr = 47.48 %
- Practice = 1993 Hr = 52.52 %

Figure 4: BSN Curriculum (MOH, 2007)

Nursing Training Course

Nurses are responsible for treating patients, educating patients about medical-related diseases and performing basic medical tests and procedures. Career requirements for nurses vary by position and duties; however, all nurses must receive postsecondary training and clinical experience prior to employment.

Nursing schools play major roles to train nurses in different courses. In order to promote nursing management at all levels of health care facilities, 1-year

chief nurse program was provided to nurses and midwives who had high position in hospitals. Royal Thai Government, through Chulalongkorn University provides scholarship to Cambodian nurses both Master of Nursing Science, and PhD program. WHO provides financial support for upgrade faculty from ADN to BSN. JICA also offer financially support to bring Cambodian nurses to study BSN program at Saint Louis College of Nursing, Bangkok, Thailand.

9. Clinical requirements for BSN Students

	Nursing Procedures	S4	S5	S6	S7	# Requirement	
						Perform	Perform with supervision
Fundamental Nursing I, II							
1	Sterile gloving	x				10	
2	Measuring body temperature	x				20	
3	Assessing radial pulse	x				20	
4	Assessing respirations	x				20	
5	Assessing arterial blood pressure	x				20	
6	Risk assessment, skin assessment, and prevention strategies of pressure ulcer	x				5	
7	Administering intra dermal injections		x			10	
8	Administering subcutaneous injections		x			10	
9	Administering intramuscular injections		x			20	
10	Initiating intravenous therapy		x			20	
11	Initiating Blood therapy				x		5
12	Monitoring for adverse reactions to transfusion				x	5	
13	Applying a wet to dry dressing			x		10	
14	Preparing the client for surgery			x			5
15	Performing postoperative care of the surgical client			x			5
Adult Nursing Methodology I, II, & III							
1	Care of the client in skeletal traction and pin site care				x	5	
2	Performing oro pharyngeal suctioning			x		5	
3	Applying nasal cannula or oxygen mask			x		10	
4	Caring for clients with chest tube connected to disposal drainage system				x	5	
5	Intubating the client with a naso gastric feeding tube			x		5	
6	Inserting a indwelling catheter			x		20	
7	Performing wound suture				x	5	
8	Performing suture removal			x		10	
9	Performing Abscess incision				x	5	
Internship							
1	Medical cases presentation by applying Nursing Process					5	
2	Surgical cases presentation by applying Nursing Process					5	
3	Pediatric cases presentation by applying Nursing Process					5	
Total : 27 Procedures							

Figure 5. Clinical Practice Requirements for BSN (Ministry of Health, 2007)

Nursing Research

Even we know that nursing research is very important to nurses. However, there is limitation of conducting research, especially nursing research on education. However, we have occasionally cooperated with external researchers to conduct some studies in nursing education.

Challenges of AEC for Nursing Education, Cambodia:

1. Aligning education with clinical practice:

As a critical component of the healthcare industry, the nursing profession must keep pace with changes in the healthcare system to insure the continued delivery of high quality, safe, and effective patient-centered care. To stay current, new nurses must be educated and equipped with relevant and appropriate competencies, knowledge, skills, and attitudes. In order to plan for the future, it is first necessary to assess requirements for the workforce, based on expectations of the work environment, and develop the education required for nurses to fill those roles. It is almost the same statement with ANA, which stated, “The public has a right to expect registered nurses to demonstrate professional competence throughout their careers. ANA believe that it is the nursing profession’s responsibility to shape and guide any process for assuring nurse competence. Assurance of competence is the shared responsibility of the profession, individual nurses, professional organizations, credentialing and certification entities, regulatory agencies, employers, and other key stakeholders.” (American Nurses Association, 2008)

2. Improvement of nursing educators

Quality education depends on well-prepared faculty members. Faculty development and faculty vacancies are critical challenges in nursing education. The nursing shortage poses a significant threat to healthcare delivery in the future. Insufficient capacity in nursing schools is a major contributor to the shortage of nurses and the shortage of nursing faculty is a major cause of the capacity constraints.

In addition to increasing both quantity and quality the number of faculty members are able to incorporate evidence-based teaching practices more effectively and teach nursing students the skills that will be required. Nursing schools require faculty who are experts in nursing education and who must possess the knowledge to serve in an advanced practice role. Furthermore, deans of schools of nursing are needed to complement these experts and act to create systems that value and reward expertise in nursing education. Finally, we need to prepare faculty members to retain clinical skills therefore they can guide nursing students to practice accordingly to the school learning goals.

3. Promote BSN, Master and PhD level:

Across the nation, the employ BSN level's nurses at each level of health care facilities, which increase the numbers of baccalaureate nurses rather than ADN nurses. In order to achieve this promotion, each health facilities have to facilitate nursing staff, which they want to seek bridging course from ADN to BSN. Furthermore, the acceleration of baccalaureates to Master and PhD of Science in nursing programs is much needed. Therefore, we can have expert nurses that can work at specialty areas of practice.

4. Improvement faculty shortage:

The current nurse faculty shortage is very crucial. One of the challenges is that hospital director may send some staff to nursing school, and then that nursing school teaches these staff nurses how to be clinical faculty members. This kind of academic practice exchange is gaining prominence in nursing education as a vehicle for bridging educational preparation and professional practice. Collaboration between academic institutions of nursing and hospitals or clinical agencies is a means of solving critical problems facing educators and clinicians (Horns, et al., 2007). They believe that academic-practice exchange can be an effective means for helping to address workforce shortages and that policymakers should foster such partnerships.

5. Regulation and laws:

A common thread of most approaches to nursing education involves

existing laws and regulations. The reflection on language and cultural diversity are the means to develop understanding of values and beliefs.

Conclusion

As part of the ASEAN economic community Cambodia faces an even greater challenge to ensure the demand for quality nurse education is met in the years to come. The first priority is ensuring there are sufficient nurse educators who have the skills and knowledge themselves. This, in turn, requires that nurse educators continue to pursue their own education to make sure they have the higher level qualifications now required. In addition attention to retaining these highly qualified nurse educators is vital.

It is only by meeting the demand for qualified nurse educators that Cambodia will be able to continue to educate nursing students as competent professional nurses with the right skills and knowledge to meet the demands of the profession and provide high quality nursing care in the future.

References

- American Nurses Association. (2008). "Position statement: Professional role competence". Retrieved June 25, 2013, from <http://www.nursingworld.org/MainMenuCategories/HealthcareandPolicyIssues/ANAPositionStatements/practice>.
- Allen, M. (2006). "Mapping the literature of nursing education". Journal Medical Library Association.
- Borsay, A. (2009). "Nursing History Review; role of nursing history in preparing nursing for the future". <http://www.aahn.org> (Retrieve 2013).
- Bureau of Nursing and Midwifery. (2008). "History of Nursing Education. Sub Decree". (2007). Health Professional Training.
- Ministry of Health. (2007). "National Curriculum for AND".
- Ministry of Health. (2008). "National Curriculum for BSN".

NURSING SERVICES IN CAMBODIA

Manila Prak BSN, RN

Director of External Program Department, Chairperson of Local Boards,

Angkor Hospital for Children, Siem Reap, Cambodia

pmanila@angkorhospital.org

Background

Cambodia is located in Southeast Asia bordered by Thailand to the northwest, Laos to the northeast, Vietnam to the east and the Gulf of Thailand to the southwest. Its total landmass is 181,035 square kilometers and has a population of over 14.8 million people. Approximately 95% of the population practices Buddhism (Wikipedia, 2013a).

Civil war engulfed Cambodia from 1975-1979 when the Khmer Rouge regime took power. After the Khmer Rouge fell from power in 1979 the country started from zero. Many health care professionals including nurses were killed during that time. Proper nursing schools but initially with only limited nursing education were started in the 1980's.

Table 1. Total population and their characteristics (WHO Statistic 2009)

Total Population	14, 138, 000
Gross national income per capita (PPP international \$)	2, 230
Life expectancy at birth m/f (years)	64/66
Probability of dying between 15 and 60 years m/f (per 1 000 population)	260/220
Probability of dying under five (per 1 000 live births)	43

Total expenditure on health per capita (Intl \$, 2011)	135
Total expenditure on health as % of GDP (2011)	5.7

The department of nursing services in Cambodia is under the supervision of the Hospital Services Department which is within the Ministry of Health and is called the “Nursing and Midwifery Bureau”.

The Functions of the Nursing and Midwifery Bureau are:

- To operate and develop nursing standards, a nursing service system and models for health care facilities
- To promote nursing service development by using nurses knowledge and expertise. In addition to monitoring nursing service standards in health care facilities of all levels
- To collaborate with nursing organizations and other health development partners in order to strengthen nursing practice
- To support nursing system networks in all health care facilities

Responsibilities of the Nursing and Midwifery Bureau are:

- To formulate policy and to direct nursing services for the whole country
- To undertake manpower planning in the nursing profession in collaboration with expert organizations and related institutions
- To innovate models of nursing services and quality systems
- To instruct and develop the standards of nursing services, nursing management and staff development
- To promote the quality of nursing services
- To upgrade the standard of nursing practice in the country
- To encourage nursing education

Health Care Needs

The Ministry of Health’s Strategy Plan 2008-2015, describes the health program priority areas and essential services for Cambodia, these are listed in table 2.

Table 2. Health priority areas, Ministry of Health’s Strategy Plan 2008-2015

Reproductive, Maternal, Newborn and Child Health	Communicable Diseases	Non Communicable Diseases and other health problems
Family planning and birth spacing Safe abortions Maternal and child nutrition Antenatal care PMTCT Skilled birth attendance Emergency obstetric care Integrated postnatal care of mothers and newborns Immunization including measles & tetanus elimination and introduction of new vaccines IMCI Essential pediatric care Adolescent / youth health Key family practices	Reproductive tract infections HIV/AIDS/STI TB Leprosy Dengue Fever Malaria Helminthiasis Schistosomiasis Emerging and reemerging diseases International Health Regulation implementation	Diabetes Cancer Cardio-Vascular Diseases (CVD) Mental illness, including substance abuse Blindness and deafness prevention Oral health Environmental health risks Injury, accident Occupational health Rehabilitation Elderly Food safety Tobacco control

Nursing Needs

Due to the country’s turbulent history, the needs of the nursing profession in Cambodia are great. They include building up the profile of the profession, creating infrastructure, strengthening education, national protocols and guidelines and establishing an ethical framework. Excellent progress has been made and work on these needs has begun.

In 2010, in response to the health care needs described above, the Bureau of Nursing and Midwifery sought financial and technical support from a few health care, non-governmental organizations. The aim was to help improving health concerns, which has seen as significant from a nursing point of view. Subsequently one such project “Better Health Services” was funded by USAID and implemented by the University Research Corporation (URC) and Angkor Hospital for Children. This project supported the Nursing & Midwifery Bureau through the Hospital Services Department of Ministry of Health. The overall project goal was, with the Ministry of Health “to provide stewardship for the

entire health sector and to ensure a supportive environment for increased demand and equitable access to quality health services in order that all the peoples of Cambodia are able to achieve the highest level of health and well-being”.

The project committee is led by the Chief of Nursing & Midwifery Bureau and members include senior nurses from national hospitals, regional hospitals, where nursing schools are located, stand-alone nursing schools, Angkor hospital for children, University Research Corporation, Volunteer Services Overseas and giz. Below are listed a selection of projects started since 2010.

1. Development of national nursing and midwifery protocols as a guidance for all health care facilities in Cambodia. In total 28 protocols were developed and these were finalized by the Ministry of Health and were implemented, with training, in January 2013 (Table 3).
2. Development of the Code of Ethics for Cambodian Nurses. The final draft of the code has been approved by MoH and is now with the Council of Ministry waiting for final approving.
3. The National Nursing Conference; this conference has been conducted every year since 2008. From 2013 it will be held every the other year.
4. The International Nurses Day: this event has been conducted yearly since 2011 and will continue to do so in the future.

Table 3. The 28 protocols developed by the Project Committee

	Vital Signs
1	Axillary Temperature
2	Oral Temperature
3	Rectal Temperature
4	Radial Pulse
5	Apical Pulse
6	Blood Pressure
7	Respiratory Rate
8	Oxygen Saturation

	Drug Administration
9	General Drug Administration
10	Oral Drug Administration
11	Intramuscular Injection
12	Intravenous Injection
13	Intradermal Injection
14	Sub-cutaneous Injection
15	Eye Drug Administration
16	Ear Drug Administration
17	Nose Drug Administration
18	Nebulizer Therapy
19	Sublingual & Buccal Administration
20	Patch Administration
21	Topical Administration
22	Rectal Administration
23	Vaginal Administration
	General Protocols
24	Oxygen Therapy
25	Oral/Nasal/Pharyngeal Suction
26	Nasogastric Tube Insertion
27	Indwelling Catheter Insertion
28	Wound Care

Health Care and Nursing Systems

The Cambodian Ministry of Health (MoH) is solely responsible for all the country's health needs.

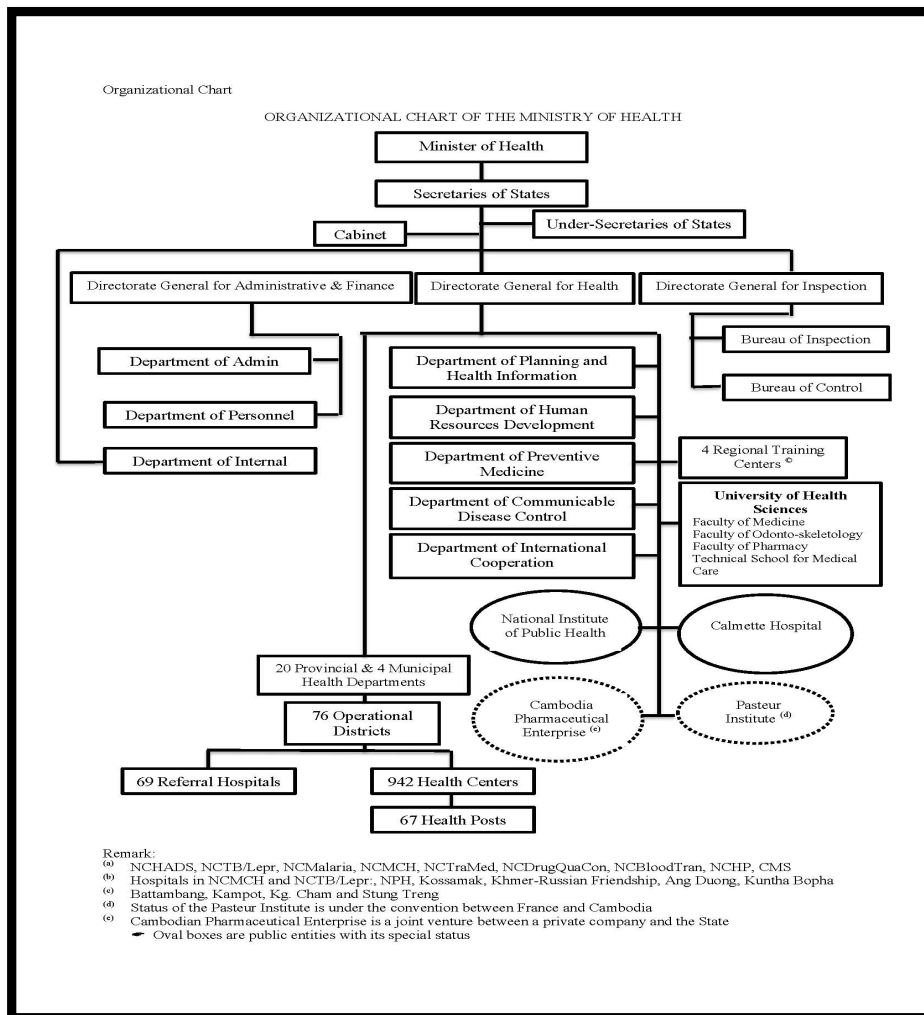

Figure 2: Organizational chart for the Cambodian Ministry of Health

These include the development of strategic plans and the implementation and evaluation of public health services in Cambodia (MOH, 2009b). The mission statement of the MoH is “to be the leading government institution responsible for administrating and managing health services in Cambodia”. The organization chart is seen in figure 2 (MOH, 2009a).

Provision of Medical Services

The Operational District (OD) is the basic functional unit for the provision of medical services. The first contact for the public is the health center, which provides a minimum package of activities (MPA). The second level is a referral hospital, providing a complementary package of activities (CPA). A provincial

hospital has a special status as it plays both a role for a referral hospital in an OD in which it is located and also for other ODs within the province (MOH, 2010).

Referral hospitals are classified into 3 categories based on number of staff and physicians, a number of beds, medicines and medical equipment, and clinical activities.

CPA 1: a referral hospital that has no grand surgery (without general anesthesia) but at a minimum should have an obstetric service

CPA 2: a referral hospital which has more activities than the first category but less than the third one, namely it has emergency care services and grand surgery (with general anesthesia)

CPA 3: a referral hospital with the highest level of activities, namely it has grand surgery (with general anesthesia) and more activities (both number of patients and activities) than the second category, in addition it also has specialized services.

Level of Nursing Staff Including Level of Education and Competency

In Cambodia the nursing and midwifery professions are split. The Nursing & Midwifery Bureau within the Ministry of Health is ultimately responsible for all nursing and midwifery duties. However there are separate councils for both professions. These councils have different associations, regulations and code of ethics.

Although nursing and midwifery education occur separately, they follow the same standards. One challenge is that midwives are only now recognizing and understanding the concept of nursing process, when the concept has already been introduced. It has taken time and effort to obtain understanding that both professions are derived from the same basic principles; that of caring.

Our caring professions, nursing and midwifery, would stronger if they worked together to make two in one.

There are three levels of staff nurses in Cambodia (Table 4). All three levels of nurses work in every type of hospital or health center. Only graduate

nurses with an associate degree or bachelor degree can work in nursing education or administration institutions.

Table 4. Grades of nursing staff within Cambodia

Grade	Length of nursing education	Competency
Primary Nurse	Study 6 months to one year	Provide routine care with health teaching to patients. Able to perform non-complicated nursing procedures. Work under the supervision of professional nurses.
Associate Degree in Nursing	Study 3 years	Provide routine care with health teaching to patients. Can work as manager, chief nurse and be involved with the continuing education program
Bachelor of Science in Nursing	Study 4 years	Provide routine care with health teaching to patients. Can work as manager, chief nurse and be involved with the continuing education program

Manpower

The hospital nursing structure is good; however the role of nurse is not yet independent. In terms of providing care to patients, nurses usually follow doctor's orders. There is one nursing unit in each hospital that responsibility of which falls under a nurse in the position of Chief of Nursing. In each ward there is a head nurse and deputy head nurse. In some hospitals nurses hold the position of deputy director or chief of the technical. In the Ministry of Health nurses hold positions such as the chief of the Nursing and Midwifery bureau and its officers. Within the nursing council all positions are held by nurses including the president of the council. In nursing schools, nurses hold positions which include the chief of the

technical bureau, clinical instructors and administrators. All directors of the nursing schools are medical doctors. Due to the shortage of nurses and the fact that the nursing process is not well known, the quality of care and independence of the profession are limited.

Demand and Supply of Nursing Staff

Nursing shortage refers to a situation where the demand for nursing professionals, exceeds the supply, either locally (e.g. within a given health care facility), nationally or globally. It can be measured, for instance, when the nurse-to-patient ratio, the nurse-to-population ratio, or the number of job openings necessitates a higher number of nurses working in health care than currently available (Wikipedia, 2013b)

Globally, the World Health Organization (WHO) estimates a shortage of almost 4.3 million nurses, physicians and other health human resources worldwide - reported to be the result of decades of underinvestment in health worker education, training, wages, working environment and management.

Nursing shortage is a global shortage (Walker, 2011) but rich countries can recruit nurses from less wealthy countries that option is not opened to poorer countries. In addition to this so called “brain drain” many of the population living in these countries cannot afford the cost of training to be a nurse. Low wages paid to the nursing profession globally mean that they do not cover the cost of three or four years studying.

Cambodia faces a desperate nursing shortage. Using Department of Personnel data (table 5) Cambodia has 0.9 nurses per 1000 population this is 10 times less than countries such as the United Kingdom and Australia (ilibrary).

In most hospitals and clinics in Cambodia the team nursing method is used to provide care for patients. The estimated nurse-patient ratio in Cambodia is 1:16-20. Nurses are overwhelmed with too many patients and are therefore unable to provide quality care. Nursing shifts in most hospitals are 24 hours long. Angkor Hospital for Children and a few NGO hospitals are the only places which

have shifts lasting eight or 12 hours. Nursing process is being used at AHC to provide holistic care for patients as well as to strengthen nursing professional autonomy. AHC works closely with the MOH to achieve this mission.

Table 5. Numbers of practicing nurse in Cambodia

Grade	Number
Primary Nurse	3407
Primary Midwife	1829
Associated Degree in Nursing	5198
Associated Degree in Midwifery	1882
Total	12, 316

Licensing and registration

To practice nursing in Cambodia any graduates from either Cambodia or from abroad need to pass the national exit examination and to receive the Professional License of Nurse certificate which is issued by the Ministry of Health. To pass the national exit examination license of nurse the following must have:

- A diploma of the nursing national exit examination
- Have no record of misconduct that would be considered threatening to the honor of the profession
- Have no criminal record
- Have health certification

The Ministry of Health is responsible for the registration and for the professional license of nurses. Foreign nurses who work as technical advisors or those who perform nursing practice must bring their local professional license.

Under the financial and technical support of the URC and AHC, the Bureau of Nursing & Midwifery works closely with hospitals chief nurses to aid the continuing education of nurses. The team including members from MOH, URC, AHC and the local hospital meet to discuss and ensure that the training happens at the hospital level. The ongoing training programmes are: Nursing protocol training of trainer, Nursing protocol training for staff nurses, Nursing

process training of trainer, Nursing process training for staff nurses, Infection control.

Research development

Nursing research is limited in Cambodia. At Angkor Hospital for Children, nurses are involved in research projects with medical doctors or nurses from overseas such as England, United States and Australia. We also use evidence based practice to improve the quality of patient care. In addition the Chief of the Bureau of Nursing & Midwifery of the MOH committed to make research projects available for all Cambodian nurses after he gained his PhD from Chulalongkorn University. The Cambodian Oxford Medical Research Unit is a partnership between Oxford University, England and AHC. The unit is conducting many clinical research projects and is dedicated to assisting all nurses who wish to be involved in research.

Challenges of Asian Economic Community for Nursing Services in Cambodia

The Association of Southeast Asian Nations or ASEAN was established on 8 August 1967. The ASEAN is a regional association composed of the ten countries situated in a region covering an area of 4.46 million km² (equivalent to approximately 3% of the total land area of the earth) figure 3. These countries are home to 600 million people, which is nearly 9% of the world's population. ASEAN was formed under the "3 pillars" of regional cooperation: security, socio-cultural integration, and economic integration. In 1997, ASEAN leaders declared the ASEAN Vision 2020, which aimed to transform ASEAN into a "stable, prosperous and highly competitive region with equitable economic development, and reduced poverty and socioeconomic disparities." Building on this vision, at their 2007 Summit ASEAN leaders affirmed their strong commitment to accelerate the establishment of an ASEAN Economic Community (AEC) by 2015 (Pornavalai, 2012). As a single market and production base, the AEC comprises

the following five core elements: Free flow of goods, services, investment, capital, and skilled labor

The Objectives of ASEAN Mutual Recognition Arrangement on Nursing Services

The objectives of the mutual recognition are summarized below (ASEAN)including: Facilitate mobility of nursing professionals within ASEAN; Exchange information and expertise on standards and qualifications; Promote adoption of best practices on professional nursing services; and Provide opportunities for capacity building and training of nurses.

The mutual recognition arrangement on nursing services introduces great challenges for nursing services within Cambodia as the following conditions exist: 1) There is a lack of nursing resources for both service provision and education in Cambodia; 2) Nurses do not have fully independent roles in performing their work and in decision making within the profession or in communication with other disciplines; 3) There are a shortage of nurses which means that holistic nursing care cannot be carried out; 4) Knowledge of continuing educational development for nurses is limited; 5) There is a lack of commitment and motivation due to the lack of support from those at the management level; 6) Nursing is not seen as a profession within Cambodia; 7) The quality of patient care in some health care settings still does not meet the professional standard required.

Conclusion

The mutual recognition arrangement on nursing services could be a great opportunity for the nursing profession within Cambodia. Increased support from the ASEAN countries could help to improve the points listed above. Nursing should reach the same high standards no matter which county.

“Nursing is an art. It is one of the fine arts: I had almost said, the finest of arts.” (Florence Nightingale)

References

- ASEAN. "ASEAN Mutual Recognition Arrangement on Nursing Services". Retrieved 25th June 2013, from <http://www.asean.org/communities/asean-economic-community/item/asean-mutual-recognition-arrangement-on-nursing-services>
- Library, OECD. Nurses Retrieved 29th June 2013, from <http://www.oecd-ilibrary.org/sites/factbook-2011en/12/03/02/index.html?contentType=&itemId=/content/chapter/factbook-2011-111en&containerItemId=/content/serial/18147364&accessItemIds=&contentType=text/html>
- MOH. (2009a). MOH Departments Retrieved 25th June 2013, from http://www.moh.gov.kh/?page_id=1413&lang=en
- MOH. (2009b). "Strategic Plan". Retrieved 25th June 2013, from http://www.moh.gov.kh/?page_id=1413&lang=en
- MOH. (2010). "National Guidelines on Complementary Package of Activities for Referral Hospital Development (2nd ed.)".
- Pornavalai, Cynthia. (2012). "Thailand: ASEAN Economic Community 2015 and Thailand". Retrieved 25th June 2013, from <http://www.mondaq.com/x/166614/International+Trade/ASEAN+Economic+Community+2015+and+Thailand>
- Walker, Jennifer. (2011). "The Global Nursing Shortage". Retrieved 29th June 2013, from <http://magazine.nursing.jhu.edu/2010/08/the-global-nursing-shortage/>
- Wikipedia. (2013a). Cambodia Retrieved 29th June 2013, from <http://en.wikipedia.org/wiki/Cambodia>
- Wikipedia. (2013b). "Nursing shortage". Retrieved 25th June 2013, from http://en.wikipedia.org/wiki/Nursing_shortage

NURSING EDUCATION IN INDONESIA

Dewi Irawaty, MA., PhD.

Faculty of Nursing Universitas Indonesia,

UI Campus Depok 16424 – Indonesia

Email: d_irawati@ui.ac.id

Abstract

Indonesia nursing education was transformed to be tertiary education on 1985 in order to fulfill demand of professional nursing services. In respond to national development in education under the Higher Education Act 2012 nurse educators qualify minimal is a master/ specialist in nursing. It is also regulated that the registration status has to extend by fulfilling the 25 professional credit hours including working experience and continuous professional development provided by nurse group interest.

Introduction

Indonesia is an archipelagic island country in Southeast Asia, lying between the Indian Ocean and the Pacific Ocean. It comprises five main islands: Sumatra, Java, Borneo (known as "Kalimantan" in Indonesia), Sulawesi, and New Guinea. Indonesia is the world's most populous Muslim-majority nation, with almost 86.1% of Indonesians declared Muslim, 8.7% of the population is Christian, 3% are Hindu, and 1.8% Buddhist or other.

Rapid changes in the health care development have forced the Indonesian government to make changes in the health care improvement including. Since the

early 2000 it was set that the minimum standard for nursing entry to practice in the health care system in Indonesia is diploma level. The Indonesia government is committed to increasing the quality of nursing care through improvements in nursing education. The health services need nurses with quality knowledge and skills who are able to cope with the increasing complexity of health care. Thus, nursing education must provide students with a firm foundation for lifelong learning on which nurses can continue to build throughout their professional careers.

However, at present there is a gap between nursing education and health care needs because the improvement in the nursing educational level has not been followed by improvement in the quality of teaching and learning.

Indonesia health services relies upon nurses to provide health care in a variety of settings. The Ministry of Health employs about 60% of nurses while the remainder work in the public sector. While there is a need for quality nurses, the limited funds available for health care has created limited support for nurse development.

Nursing Education in Indonesia

Nurses comprise the largest health worker category in Indonesia, accounting for roughly 44 percent of health staff in government hospitals. Around 50 percent of Indonesia's nurses graduate from "Sekolah Perawat Kesehatan" (a three year basic nursing course at senior high school level), which they enter following completion of junior high school. This three year basic nursing program was initiated in 1975. Right now, Indonesia has three type of nursing education:

- Diploma Nursing Education
- Bachelor (undergraduate) of nursing
- Graduate Nursing Education

Diploma nursing program: this is a three year nursing course that is conducted in school of nursing and students come from senior high schools. The diploma nursing program was initiated in 1962 and most nursing schools are in the

large cities and regional capitals. Graduates from the diploma of nursing are the second largest group of nurses and account for 40 percent of all nursing graduates.

The bachelor (undergraduate) of nursing (tertiary degree): this is four-year nursing course that students in take is from high school and offered at state and in private universities in Indonesia. Admission is based on a national examination and all the bachelor programs use the same core curriculum. The Bachelor of Nursing degrees were established in 1985 under the jurisdiction of the Ministry of Education and Culture. The graduates of bachelor nursing courses account for 5 percent of the nursing workforce.

Graduate nursing education: since 1998 was established the Master/ Nurse Specialist Education area of community health nursing and master in nursing leadership and management of nursing. In the later year followed by pediatric nursing, maternity nursing, psychiatric nursing, and medical surgical nursing. In 2008, Doctor in Nursing education was started in Universitas Indonesia.

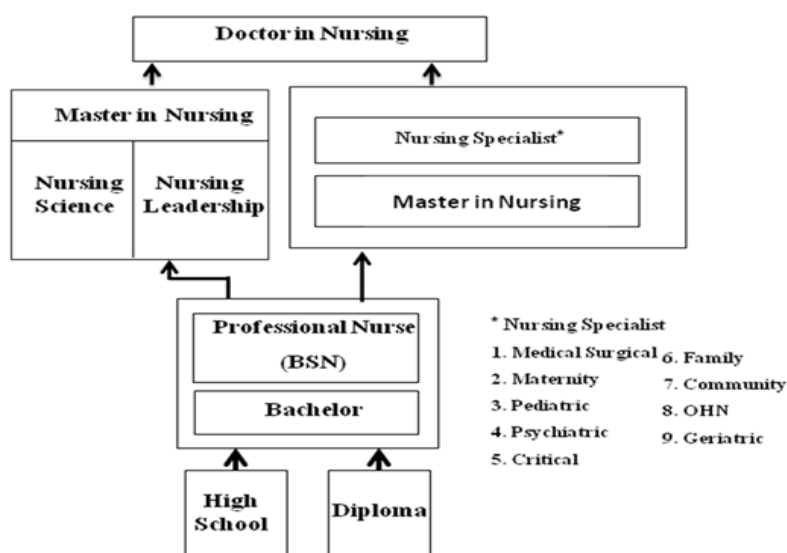

Picture 1. Nursing Higher Education System

The academic year starts in September and ends in December with a month break and the second semesters begins in February and ends in June with 2 months break. Degree completion programs are also provided for technical nurses who want to further their education and study for additional 2 years.

Nursing Curriculum

Diploma

All diplomas nursing in Indonesia are based on a national nursing curriculum for diploma nursing courses. The content of the diploma nursing curriculum is 80 percent of the national content, which means that all nursing schools in Indonesia provide the same content and 20 percent of local content so each school can provide different content depending on local/ regional needs. The diploma nursing curriculum document states that the curriculum is guided by the goal of national education, rules, norms and ethics of science, community needs, and considerations of personal interest, capability and initiative. The diploma nursing curriculum is used for all nursing education in Indonesia. The aim of the specification is to standardize nursing education to a certain level throughout the country. The diploma nursing curriculum is a very specific document that describes the number of credit points, subjects, objectives and structure of the courses. This curriculum is six semester in length and consist of 40 subjects. The subjects in the nursing curriculum can be divided into three major areas: supporting theoretical science, professional nursing subjects and clinical nursing subjects. The semesters are 20 weeks in duration, including the examination period. The semesters are structured such that the first two semesters have a higher theoretical load than clinical load, with student spending about six to eight hours a week in clinical learning. Much of the theory is given prior to the clinical component.

Bachelor

The first pathway is Regular BNS for students who have graduated from senior high school. It takes 10 semesters to get a bachelor degree (144 credits for academic stage and 25 credits for professional stage). Another BNS pathway is Extension program (including morning and evening classes) for students who have completed a Diploma of Nursing. It takes 5 semesters to get the bachelor degree which requires completing 62 credits for academic stage and 25 credits for professional stage.

Master

Master education in Nursing offers programs of study for student with prior nursing experience and for registered nurses who want to gain specialty practice skills with a component of thesis and other health care professionals who want to commence or develop research careers. The program offered, as the following: 1) Master programs, with one the following streams; leadership & nursing management, maternity nursing, pediatric nursing, adult nursing, psychiatric nursing, and community health nursing; 2) Nursing specialists programs, with one of the following one of the following specializations; maternity nursing, pediatric nursing, adult nursing, psychiatric nursing, and community health nursing. It takes 4 semesters to lead the award of Master of Science in Nursing and 2 semesters to lead the award of nurse specialist.

Accreditation

After the National Education Act No. 20/2003 and the Directorate General Directive of Higher Education Long Term Strategy 2003 – 2010, and then the Government Regulation for the National Standards for Education No. 19/2005, a new Ministerial Decree has given a new mandate for Accreditation Board for Higher Education to improve and implement the accreditation system for higher education institution. The mandate is also given to any other independent self-supporting accreditation board which until know still in the preparation stage. The intention and readiness of the existing independent professional and education association are progress to setup such board. In health education, the government has issued an Act on National Health that given mandate to certificate health workers and to develop and implement accreditation for health education programs. Following the act, preparation to setup an accreditation board for health education programs is in process. The Indonesian Health Committee organizes the development of the accreditation system for health education including the accreditation board so called Independent Accreditation Board (LAM). It is the commitment of the Government of the Republic of Indonesia to support all the

cost needed for higher education accreditation process. Any program that applies for accreditation must satisfy the eligibility requirement. Programs that are eligible to apply for accreditation must be able to present their legal status and operational license issued by the Directorate General of Higher Education (DGHE) of the Ministry of Education. The current accreditation instrument is developed based two groups of standards, the first group reflects components of leadership and institutional development and the second group reflects components of quality, efficiency, and effectiveness of the program. The following lists are the standards used for accreditation. Standards reflecting components of leadership and institutional development are:

1. Integrity, 2. Vision, 3. Governance, 4. Human Resources, 5. Facilities and infrastructure, 6. Funding, 7. Information System, 8. Sustainability. Standards reflecting components of quality, efficiency and effectiveness are 1. Students, 2. Curriculum, 3. Methods of learning, 4. QA mechanisms, 5. Management, 6. Academic atmosphere. The standards are reviewed based on nine aspects that are (1) appropriateness, (2) adequacy, (3) relevancy, (4) academic atmosphere, (5) efficiency, (6) sustainability, (7) selectivity, (8) productivity, and (9) effectiveness. The assessment relies on quantitative approach by scoring and weighting the standards.

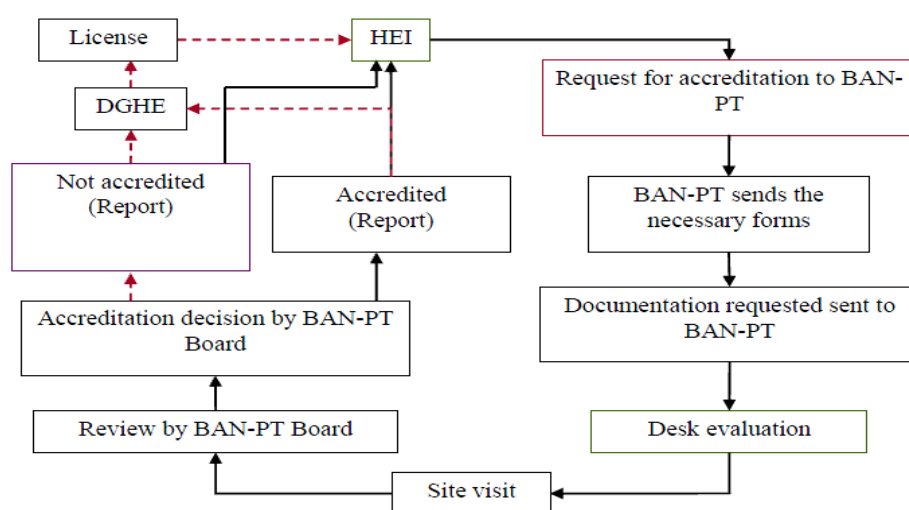

Picture 2. Accreditation process in Indonesia

AN-PT has no authority give any sanction to the programs. The sanction is given by the DGHE through access restriction to some incentive scheme for program development. The DGHE offers some competitive grant schemes for program development based on the level of accreditation obtained. Moreover, by law, according to the National Education System Act No. 20/2003, Article No. 61, certificate only can be issued by accredited programs. Hence, the accreditation becomes mandatory and by now awareness of most HE Institution to apply accreditation keeps increasing.

The accreditation is granted for 2 – 5 years. The review includes the curriculum, numbers of faculty and their qualification, infrastructure, to support the educational programs, and financial resources available to provide quality educational offerings.

Credentialing

In 2011 the first national examination nursing graduates was administered by the Health Workforce Council (MTKI). Prior to this time graduation from an approved school of nursing or university was all that was required for licensing. The license is renewed every 5 years. The examination covers six areas and is administered three times a year. The student must pass each individual section.

The MTKI has decided on conducting 3 national competency examination per year, starting with nursing and midwifery. Because of time constraints, there will only be one examination for 2013. The methodology will be a MCQ Knowledge Based test (Computer Based Test for profession level (Nurse/Ners) and Paper Based Test for D3 level). The schedule is 12-13 October 2013 for professional nurse, 2 November for vocational nurse (D3), and 9 November for vocational midwife. This first national examination will take advantage of two national examination trial runs to be organized by the LPUK in July and September this year. The purpose of the trial runs is to test the examination system, examination items, examination management, and unit cost simulation.

Nurse Educator

In relation to teacher or faculty member is under the teacher and faculty act publish in 2009. It is regulated that the qualification to be faculty in higher education should be minimum graduate of master education related and also have been holdings teacher certificate. According to that act, the nursing education standard was also regulated the minimum qualification is master education or more specific is a nurse specialist in the same area he/ she going to teach. The teaching certificate should be updated every year by fulfilling the portfolio which mentions that he/ she successfully accomplished total 12 – 14 credits hours, including teaching, research, and conducting community services. Unfortunately, almost half of teaching staff in nursing education have not holding the master/ specialist in nursing. According to the existing regulation that qualification should be fulfilled by every teaching staff by 2015. Therefore the government, together with the nurse association and nursing education association are looking very hard all possible opportunity for solving the problem. For time being only 12 nursing higher education provide the master education for those unqualified staff to achieve the master education background.

Some nursing education institution sent their staff to study abroad. Unfortunately nor every teaching staff could participate with this program since they have some initiation such as family problem, language, etc. Government through Ministry of Education provide special financial aid for overcome those problem and encouraging those staff who have fulfilled the requirement to study in master education. In specific it is required by the year 2015 at least 6 teaching staff in a bachelor program are holding master/ specialist in nursing.

Continuous Professional Development

Nurse is a professional health worker therefore like others professional he/ she have to maintain his/ her professionalism. One activity he/ she have to attend is in continuous professional development program (CPD). Under Indonesia National Nurses Association (INNA) there are several committees with the

specific activity and responsibility. One of the committee is specific area/ group interest with the main responsibility is to conduct the CPD program mainly for their members. It is regulated that the registration status should be extended by submitting the recommendation from the INNA. This recommendation given based on the achievement made in CPD, working experience, participate in related scientific program and participate in professional activity such as board member nursing association program or attending related activity. Therefore the specific interest group in every year has to prepare a program to be observed by their member in specific or to others who are also interested to participate.

Conclusion

It is certainly that every member country responsibility to make the ASEAN Economic Community (AEC) 2015 successful. Nurses as one professional in health team and comprised as larger number supposed to contribute to those success. Many activities should be created to achieve the goal including any activities related to Nursing Education. Indonesia as one of ASEAN Community in the preparation stage specially in maintaining the high quality of Nursing Education.

NURSING SERVICES IN INDONESIA

*Rita Sekarsari SKp., Sp KV., MHSM.,
Cardiac Centre Hospital, Jakarta, Indonesia
S Parman Kav 87. Jakarta Barat – Indonesia
Email: ritaakbar@yahoo.com*

Abstract

Nursing services is an integral part of the health care. Its implemented by various levels of vocational competence and professional nurses, which can be obtained through various forms of education-training and additional ways, such as through certification and continuing education programs in the Higher Education System of Nursing. In maintaining and increasing quality of nursing services and patient safety, all of nurse delivering care in clinical areas must have licence, as it stated in Hospital Act No 44/2009 and Health Law No. 23/1992 and several other health related laws. There are a few factors influencing the quality of nursing services in Indonesia such as: ratio of bed and nurse, education qualification, distribution, the career ladder and reward system, facilities as well as the nursing regulation.

Introduction

Indonesia's development strategies in health sector are alongside with the long term plan development. In the National Long Term Development Plan (RPJP-N) from 2005 to 2025, stated that in the realization of human resources (HR) quality and competitive, then together with health education and increased

purchasing power of families / communities are the three main pillars for improve the quality of human resources. In RPJP-N, also stated national development in the health sector aimed to increase awareness, willingness and ability of healthy life for every person in order to increase the degree of the highest health can be realized.

A range of geopolitical factors has affected the economy in Indonesia. Current poverty estimates suggest that almost a third of Indonesia's population still living below the World Bank poverty line, with all the implications this has for their health status. Poverty levels have contributed to a number of serious health problems such as: sharp rises in communicable diseases, including TB, cholera, malaria and acute respiratory illness; compromised nutrition leading to Vitamin A and Iron deficiencies, goitre and xerophthalmia; and diabetes. Not only do these problems pose serious risks for the population's health and the country's economic viability, they also present a significant challenge for the health service.

The health care system, widely accepted to be underfunded, with just 2% of the GNP being spent on health care, has created an obvious shortfall in equipment, supplies and health care personnel; moreover, it has affected their education and training. On 2010, an estimated 56 percent of Indonesian, mainly state employees, low-income earners and those with private coverage have some form of health insurance. It will boost to 100 percent with a system of universal social health insurance coverage in place by 2014. The aim is that everybody doesn't have to pay when they are hospitalized in basic/class-3 hospital beds. Indonesia's health care is delivered through an extensive primary care system which relies heavily on nurses and midwives for its efficacy and success, it seems self-evident to note that the preparation of these personnel is crucial to the effective functioning and delivery of clinical services. Moreover, because of the pressure on services and the wide variations in terrain and population levels, continual updating of health care professionals is required if they are to meet very specific local needs. Consequently, nurses must not only develop the clinical skills to manage serious diseases, but also must be sensitive to the cultural needs of the

patient and family, while simultaneously operating in adverse environmental conditions with limited equipment and resources.

Regarding that situation above all health stakeholders should support each other in improving and enhancing the quality of health status. Nurse in this regard has a pivotal role due to its position (always contact with patient) and its great contribution to achieve this objective.

Health Care Needs & Nursing Needs

Currently about 237.5 million of Indonesia population is served by 220,004 nurses. In term of the ideal proportion Indonesia should have 117 nurses for every 100 000 population. According to the Ministry of Health (2013), currently there is 2138 hospitals (1648 general hospitals and 490 specialist hospitals) served by Medical Specialist Doctor 16,802, General Practitioner 33,30, Nurse 220,004 and Midwife 122,4000.

In Indonesia there is a shortage of nurses at health-care facilities but, in contrast with other countries, there are also many unemployed nurses. “The problem here is connected with mismanagement of nurse hiring and placement due to lack of resources. According to the Ministry of Health (2013), greatest shortage for nurses, which reached 7,180 due to until the end of 2012 there are 105 419 new nurses, are the needs in this 2013 reached 112 599 nurses. Indonesian nurses are currently working in various health facilities, ranging from nurse executive and nurse manager at the hospital or clinic. Highly demand of quality nursing care is boosted by the outstanding economic growth (6-7%) in the last ten years (Indonesia statistical bureau 2012) and relatively stable of politic and substantial growth of middle class economy. The high demand of quality health services not only impact internal, but also regional and international. Indonesia is one of the big spender on health sector and make a lucrative market for Singapore and Malaysia health providers.

At the national consultation of INNA (2010) there is some strong recommendation for Nursing which are need to: established nursing practice act

and functioning of nursing council to protect the public, nurses are united and committed with strong leadership to bring change in nursing education & services, establish reward system & professional career ladder for nurses supported by a strong CNE system, develop a center of Indonesia information system, improved social and professional image of nurses.

Health Care & Nursing Systems

The healthcare system in Indonesia consists of public and private healthcare systems. The public healthcare system is centrally organized under the Ministry of Health with funding for public healthcare expenditures coming mainly from the central government's total annual budget. About 51 percent of the healthcare facilities come under the domain of the public sector. Public hospitals in Indonesia are categorized by the area they serve, specifically categorized as one of this following:

- District hospital: public hospital and clinic provides general and specialized medical care
- Sub District & Village: "Puskesmas and Posyandu" provide basic medical care

While the private sector accounts for 49 percent of Indonesia's hospitals, it plays an important role in Indonesia's healthcare system and is a rapidly growing segment.

Public Hospitals, Private Hospitals and Clinics. In Indonesia, hospitals are categorized into one of two types: general hospital or specialist hospital (specializing in one particular medical field, including mental hospital). Based on their management or ownership, a hospital is established either as a public hospital or a private hospital. Hospital Classification General hospitals have four classification levels, A to D, depending on their facilities and their capability to serve patients. Hospitals with advanced facilities and higher capability are classified as level A. Hospitals with minimal facilities and less capability are

classified as level D. Specialist hospitals classification is based on a similar structure with only three levels, A to C. Details of the specific obligations incumbent upon hospitals in each of these classifications are yet to be seen and are to be further regulated by the Minister of Health.

Classification for Public Hospitals:

- Hospital Level A: this type of hospital houses extensive specialist medical services and extensive sub-specialists.
- Hospital Level B: this type of hospital houses extensive specialist medical services and limited sub-specialists.
- Hospital Level C: this type of hospital at least houses a minimum of four basic specialist medical services (surgical, internal, child and maternity) and
- Hospital Level D: this type of hospital houses at least basic medical facilities

Classification for Private Hospitals:

- Private General Hospital at level Priority: this type of hospital houses general medical services as well as specialists and sub-specialists,
- Private General Hospital at level “Madya”: this type of hospital houses a minimum of four specialist medical services and
- Private General Hospital at level “Pratama”: this type of hospital provide general medical service.

Nursing services exist in all level of health providers and play as major concern on health careservices. Qualifications and competence of them depend on their experiences, education and CPD followed by them. The composition of the nursing staff should comply to the government regulation and in accordance with the level or class of the hospitals and level of service provided, for instance, the ratio between bed and nurse at the hospital level A and B is 1:1 and at the Hospital level C and D is 2:3.

In term of nursing care delivery system, most of the hospital using nursing team method. furthermore, at several hospital nursing care delivery system

applied the primary nursing method, such as at private hospital and hospital level A or B.

According to Directorate Nursing Ministry of Health (2013), The need of qualification of nurse related to level services can be seen in table 1.

Table 1. Level of services

Level of Services	Nurse Qualification
Primary	Ns Sp Community + Skill Certification Diploma Nurse + skill Certification
Secondary	Ners spesialist Ners + Certification Diploma Nurse + Skill Certification
Tertiary	Ners Consultant Ners Specialist + Skill Certification Ners + Skill Certification Diploma Nurse + Skill Certification

Level of Nursing Staff

The educational profile of nurses mostly that clinical standards are often suboptimal, in that the majority of health delivery is undertaken by nurses educated to diploma (D-III), more specialist qualifications being delivered by educators with restricted clinical experience. The current situation with regard to nursing provision in Indonesia is, however, further complicated by a number of factors. First, there is no statutory regulatory authority for nurses, and consequently there are no regulatory standards for education and clinical competence (although work is in progress to develop these authorities). As already noted, the vast majority of nurses (60%) have inadequate training and preparation for the role, which creates the potential for substandard care delivery. Second, there are a number of different grades of each profession, but these are defined inconsistently and the role responsibilities attached to each grade are variably discharged.

In Indonesia, the prediction of nurse production are approximately 30,000 persons per year. The total absorptive capacity by public health sector within this five year of health development period is in exceed of 2000-3000 persons per

year, while the total absorptive capacity by private health sector is vary and depend on situation with approximately 1000 – 2000 persons per year. Unequal distribution of nurses in Indonesia is still a serious problem in Indonesia. Difficulties of geographic with lack of transportation and infrastructure facilities in most areas outside of Java, Bali and Sumatra islands cause rejection of nurses to be placement in those areas. The composition of level education of nurses in clinical areas can be seen in tabel 2* Future Composition of Nurses (2014-2019)* Future Composition of Nurses (2020-2025)*.

Tabel 2. The composition of nurses in clinical areas, based on level education

Nurse Qualification	N
1. SPK (a three year basic nursing course at senior high school level	73.994
2. Diploma III	127.096
3. Diploma IV	921
4. Bachelor / Ners	10.031
5 . Master / Ners Specialist	412
7. D-III Anesthesi Nurse	1.177
8. D-IV Anesthesi Nurse	35
9. Others	6.338
TOTAL	220.004

*Directorate Nursing Ministry of Health 2013

Table 3. Future Composition of Nurses (2014-2019)*

Nurse Specialist (5%)	Nurse Generalist plus Advance Skill Certification (15%)
Nurse Generalist + Skill Certification (20%)	
Vocational Nurse (Diploma) plus Skill Certification (60%)	

*Directorate Nursing Ministry of Health 2013

Table 4. Future Composition of Nurses (2020-2025)*

Nurse Specialist (10%)	Nurse Generalist plus Advance Skill Certification (20%)
Nurse Generalist + Skill Certification (30%)	
Vocational Nurse (Diploma) plus Skill Certification (40%)	

*Directorate Nursing Ministry of Health 2013

In regarding with providing nursing service, Indonesia has developed and implemented the clinical ladder system. It is divided into 5 level, beginner, advanced beginner, competent, proficient, expert. The purpose of this system is to train nurses to become leaders, consultant from PK 1 through PK 5. However, the problem is that not all hospitals implementing the career ladder system, may be due to ignorance and level of qualification of the education and composition are not met with requirements. All these level based on the qualification and competencies required. The diagram of nursing clinical ladder system can be seen belows.

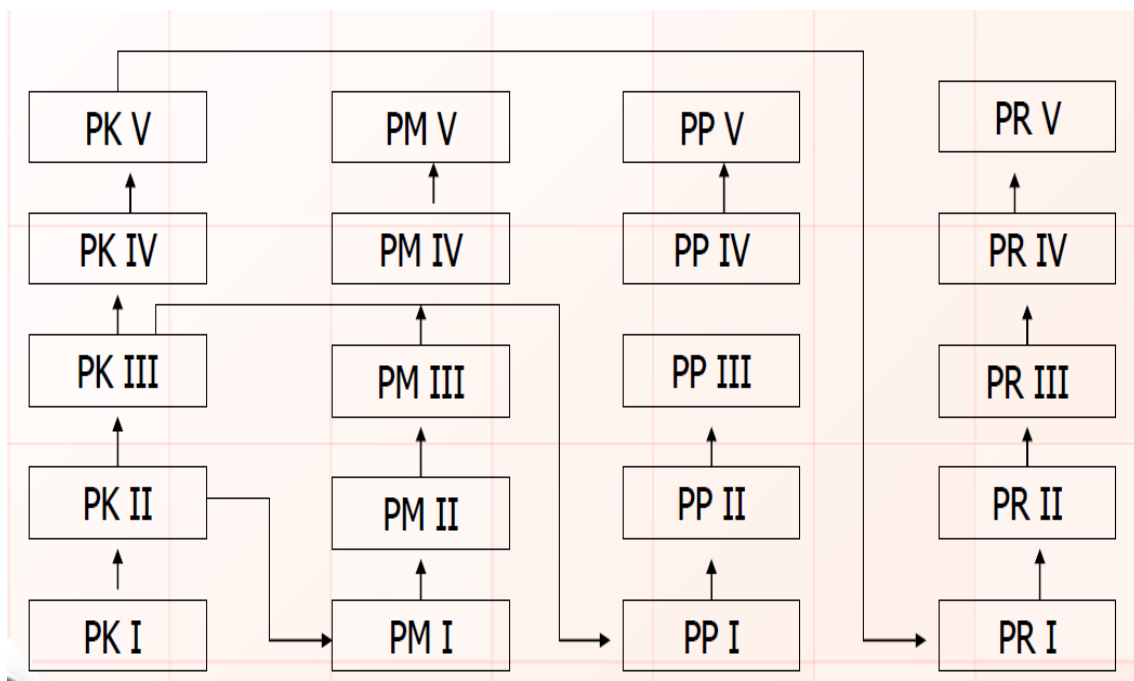

Picture 1. Diagram of nursing clinical ladder system in Indonesia

Licencing

The policy of health development in Indonesia is based on the Health Law no. 23/1992 and several regulations or decrees based on this law as well as other health related laws. Historically, only physicians and midwives have had a limited regulatory role, given by Ministerial Decree. Regarding with licence for nurses the Ministry of Health issued its first nursing decree and Nursing Practice Act No.1239/2001. In addition, in 2011 the Ministry of Health issued No 1796/2011 about registration of health workers. Its stated that all health workers undertaking their work must have the Certificate of Registration (STR) and health workers should have a diploma and a certificate of competence. Diploma and certificate of competence are given to learners after passing the educational program and competency test. Furthermore, The certificate of competence is valid for 5 (five) years and may be renewed once every 5 (five) years.

Certificate of competence that has expired may be extended by nurse through participation in educational activities and / or training, and other scholarly activities in accordance to their tasks or profession. The participation of nurse can be used as long as they meet the requirements of acquisition of Profession Credit Units (SKP). Acquisition of Profession Credit Units should reach at least 25 (twenty five) Profession Credit Units within 5 (five) years. Number of Profession Credit Units for any educational activities and / or training as well as other scientific activities is as determined by the Professional Organizations. The Professional Organizations will determine the Profession Credit Units based on: subject matter presented in an activity; presenters / speakers at the activity; level of the activity (local / national / international); number of hours / day of the activity, and role of the participant (participant / moderator / presenter).

Research development

It has been known that research development has important role in improving the quality of skill among nurses, quality of care, quality of education and/or training. Only educational institute which has post-graduate program runs

researches on nursing. Our problem concerning research development in nursing is attributed to lack of human resources, lack of financial resources. In the future, we would like to develop networking with other research institutes or universities to increase and collaborate researches on nursing.

Challenges of AEC for nursing services in Indonesia

The Protocol to Implement the 8th Package of Commitments under the AFAS (ASEAN Framework Agreement on Services) was signed in 2010. The health sector is one of the identified priority areas under AFAS and a Healthcare Services Sectoral Working Group was subsequently set up. In Indonesia, in 2006, a Mutual Recognition Agreement (MRA) was signed on nursing services and in 2009, in line with the AEC Blueprint, on medical practitioners and dental practitioners.

Challenges of AEC for nursing services could be:

- Different standards of curriculum and educational institutes
- Different professional definitions and scopes of practice
- Different levels of education to enter into professional education programmes
- Different standards of regulatory systems and licenses to practice
- Differences in continuing education and training
- Professional conservatism and protectionism
- Language barriers and cultural sensitive

Conclusion

It is clearly to achieve successful of the ASEAN Economic Community (AEC) 2015, all ASEAN Countries, public, private and community should be in synergizing optimally, efficiently and effectively. All the stakeholders such as Ministry of Health, Ministry of Trade and related Ministry and Health Professional Organizations should be closely working to achieve this goal. Importantly, in Indonesia, nurses have a pivotal role in the preparation of AEA in

improving, maintaining and increasing the quality of nursing services. In my point of view there are some strategic improvements concerning AEA, which are, nurse improvement plan, nurse training improvement, nurse placement improvement, empowerment of nurse profession and improvement of integration management of nurse among the ASEAN countries.

References

- Departemen Kesehatan RI.(2000). “Kebijakan Pengembangan Tenaga Kesehatan Tahun 2000-2010. (‘Policy of HRH Development 2000-2010’)”. Jakarta.
- Indonesia Country Report The 9th Asean Japan High Level Official Meeting On Caring Societies 2011
- Indonesia Ministry of Health. (2011). “Annual report”.
- Indonesia Ministry of Health. (2012). “Annual report”.
- Regulation of the Health Minister of The Republic of Indonesia No1796/ Menkes/ per/VIII/2011, Regarding Registration of Health Workers By the Grace of God Almighty The Minister of Health of the Republic of Indonesia.
- Regulation The Republic of Indonesia No 23. (1992). Regarding Manpower of Health Care.
- Regulation of The Republic of Indonesia No44/ / 2009, Regarding Hospital Act
- Website State Secreatry, <http://www.setneg.go.id/> National Long Term Development Plan (RPJP-N) 2005 to 2025
- Website BPPSDMK <http://bppsdmk.depkes.go.id/sdmk/>,2013
- Website World Bank, Indonesia health, <http://www.worldbank.org/en/country/indonesia>, 2013

NURSING EDUCATION IN LAO PDR

Souksavanh Phanpaseuth

Vice Dean for Academic Affairs, Faculty of Nursing Sciences,

University of Health Sciences. Vientiane Capital, Lao PDR

Email:soukphanpaseuth@yahoo.com

Nursing Education

The Ministry of Health (2011) determines the categories of health personnel needed to provide health care services. The categories of staff are classified according to level of education, the utilization of staff and professional disciplines (p.15).

The classification of the workforce according to level of education attained ;

- Post Graduate (including, PhD, Master degree and Specialist training)
- Graduate (Bachelor degree)
- Higher Diploma (Vocational High and Mid Level Professional)
- Mid-level Diploma (Vocational Mid Level professional)
- Low-level Diploma or Certificate (Vocational Low Level health worker)
- No professional recognition

Basic nursing education

The Ministry of Health is responsible for authorizing the establishment of basic nursing Institutions, while the educational programs are determined by the

institutions administration. The Ministry of Education and Sport is responsible for approval and authorization of nursing curriculum.

Qualifications for admission include the completion of 12 years of general education and pass the entrance examination which is organized by University of Health Sciences and Department of Educational and Research, Ministry of Health. The entrance examination is conducted one a year nationwide. Four subjects are examined, such as Mathematics, Chemistry, Biology and Lao language. The contents of the examination are based on Ministry of Education and Sport regulations and students can select their preferred school, college, university and program.

Nursing program

The nursing programs provided in Lao PDR are seven types such as:

- Diploma in Technical Nursing program.
- Diploma in Technical Nursing program (Continuing Education)
- Higher Diploma in Nursing program
- Higher Diploma in Nursing program (Continuing Education)
- Bachelor in Nursing Sciences Program
- Bachelor in Nursing Sciences Program (Continuing Education)
- Bachelor in Nursing Anesthesia Program (Continuing Education)

The teaching and learning consists of lectures and demonstrations in general education, basic and social sciences, nursing and medical subjects. All are given in the Institutes. Practical training, such as clinical teaching, nursing procedures, is provided also in hospitals , health centers and communities. Facilities for spots and field visits are provided.

The Midwifery program provided in Lao PDR are five types such as :

- Community in Midwifery program
- Community in Midwifery program (Continuing Education)
- Higher Diploma in Midwifery program
- Higher Diploma in Midwifery program (Continuing Education)

- Bachelor in Midwifery program

Table 1. Number of Institutions and Nursing program

Name of Institution	BNS	BNS (CE)	BN Anesth (CE)	Higher Diploma Nurse	Higher Diploma Nurse (CE)	TN	TN (CE)	BM	Higher Diploma Midwife (CE)	Community Midwife	Community Midwife (CE)
Faculty of Nursing Sciences, UHS	✓	✓	✓	✓				✓	✓		
Luangprabang College of Health Sciences				✓	✓		✓				✓
Savannakhet College of Health Sciences				✓		✓					✓
Champasack College of Health Sciences				✓	✓	✓	✓				✓
Oudomxay Public Health School						✓	✓			✓	✓
Xiangkuang Public Health School						✓	✓			✓	✓
Khammuan Public Health School						✓	✓			✓	✓
Salavan Public Health School							✓				
Vientiane Nursing school						✓	✓				

Nursing Educational System & Curriculum

System of Nursing Education

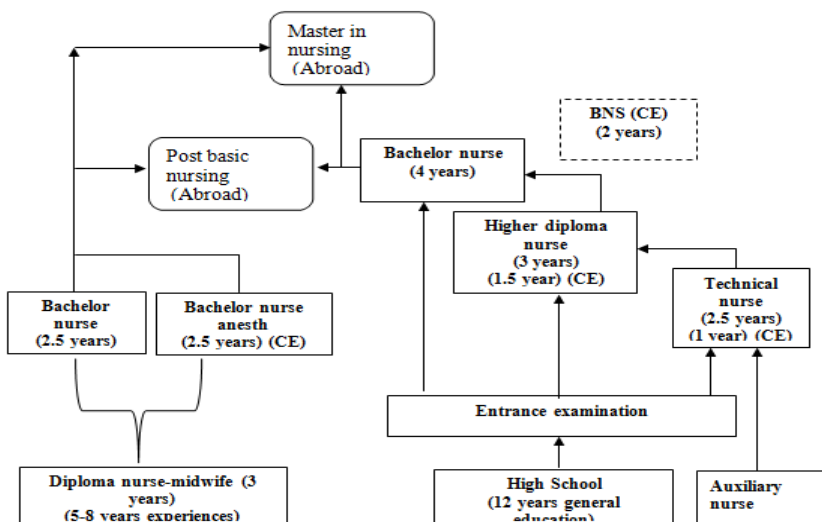

Currently, There is a unified nursing curriculum for the schools, colleges and university. There are 7 kinds of nursing curriculum and 5 kinds of midwifery curriculum issued by the MOH. Even though curriculums belong to the MOH, they need approval by the MOE.

Table 2. The Nursing curriculum

Curriculum	Duration of Study	Total of Credit
Bachelor of Nursing Sciences	4 Y	142
Bachelor of Nursing Sciences (Continuing Education)	2.5 Y	94
Bachelor of Nursing in Anesthesia (Continuing Education)	2.5 Y	76
Higher Diploma of Nursing	3 Y	107
Higher Diploma of Nursing (Continuing Education)	1.5 Y	59
Technical Diploma Nursing	2.5 Y	102
Technical Diploma Nursing (Continuing Education)	1Y	35

Table 3. Subjects of study in the 4 years Baccalaureate nursing program

Structures	Subjects	Credits
Common Subjects	CS.7101 Biochemistry	2(2-0-0)
	CS.7102 Physics)	1(1-0-0)
	CS.7103 Biology	2(2-0-0)
	CS.7104 Lao Culture	2(2-0-0)
	CS.7105 Lao Culture	2(2-0-0)
	CS.7406 Politics	3(3-0-0)
	CS.7107 General Psychology	2(2-0-0)
	CS.7108 English I	3(2-2-0)
	CS.7209 English II	3(2-2-0)
Nursing Foundation Courses	NF.7110 Nursing theory	3(3-0-0)
	NF.7211 Nursing Ethics and Regulation	3(3-0-0)
	NF.7412 Seminar in Nursing	1(0-2-0)
	FN.7413 Nursing Trend	2(2-0-0)
	NF.7214 Teaching - Learning and health Education	2(1-2-0)
	NF.7415 Leadership and Team work	2(2-0-0)

	NF.7216 Developmental Psychology	2(2-0-0)
	NF.7117 Microbiology	2(1-2-0)
	NF.7118 Parasitology	2(1-2-0)
	NF.7119 Anatomy	4(4-0-0)
	NF.7120 Physiology	3(2-2-0)
	NF.7421 English for Nursing	3(2-2-0)
	NF.7222 Nutrition	1(1-0-0)
	NF. 7223 Diet therapy	2(2-0-0)
	NF.7224 Pharmacology	3(3-0-0)
	NF.7225 Herbs	1(1-0-0)
	NF.7326 Pathology	3(3-0-0)
	NF.7327 Epidemiology	2(2-0-0)
Professional Nursing Course	NU.7129 Nursing Therapeutic	4(2-4-0)
	NU.7230 Practice in Nursing	4(0-0-16)
	NU.7331 Obstretic Nursing I	3(2-2-0)
	NU.7332 Obstretic Nursing II	3(2-2-0)
	NU.7433 Practice in Obstretic Nursing	3(0-0-12)
	NU.7234 Pediatric Nursing I	2(2-0-0)
	NU.7335 Pediatric Nursing II	3(3-0-0)
	NU.7336 Practice in Pediatric Nursing II	3(0-0-12)
	NU.7237 Adult Nursing I	3(3-0-0)
	NU.7338 Adult Nursing II	3(3-0-0)
	NU.7239 Practice in Adult Nursing I	3(0-0-12)
	NU.7340 Practice in Adult Nursing II	3(0-0-12)
	NU.7341 Gerontological Nursing	2(2-0-0)
	NU.7142 Community Health Nursing	2(2-0-0)
	NU.7343 Community Health Nursing I I	3(3-0-0)
	NU.7344 Practice in Community Health Nursing	3(0-0-12)
	NU.7345 Psychiatric Nursing	3(3-0-0)
NU.7346 Practice in Psychiatric Nursing	2(0-0-8)	

	NU.7447 Nursing Administration	3(2-0-4)
	NU.7448 Nursing Research	3(3-0-0)
	NU.7249 Basic Medical Care I	2(2-0-0)
	NU.7350 Basic Medical Care II	2(0-0-8)
	NU.7451 Disaster Nursing	2(2-0-0)
	NU.7452 Comprehensive Nursing Practicum	4(0-0-16)
Elective Course	El.7153 French	2(1-2-0)
	El.7154 Computer and Literacy	2(1-2-0)
Project	P.7455 Project Study	4(2-4-0)
Total Credits		142

Table 4 Subjects of study in the 3 years Higher Diploma Nursing program

Structures	Subjects	Credits
Common Subjects	CS. 3301 Politics	3(3-0-0)
	CS. 3302 Ethics and Nursing Regulation	3(3-0-0)
	CS. 3103 General Psychology	2(2-0-0)
	CS. 3104 Principle and Concept in Nursing	2(2-0-0)
	CS. 3105 Developmental Psychology	2(2-0-0)
	CS. 3206 Health Education	2(2-0-0)
	CS. 3107 English 1	2(1-2-0)
	CS. 3108 English 2	2(1-2-0)
	CS. 3209 English 3	2(1-2-0)
	CS. 3110 Mathematic	2(2-0-0)
	CS. 3111 Physic in Nursing	2(2-0-0)
	CS. 3112 Chemistry	2(2-0-0)
Nursing Foundation Courses	NF. 3113 Anatomy 1	2(2-0-0)
	NF. 3114 Anatomy 2	2(1-2-0)
	NF. 3115 Physiology	2(2-0-0)
	NF. 3116 Basic in Nursing 1	2(2-0-0)
	NF. 3117 Basic in Nursing 2	3(1-4-0)

	NF. 3218 Pathology	2(2-0-0)
	NF. 3119 Pharmacology	3(3-0-0)
	NF. 3120 Microbiology and Parasitology	2(1-2-0)
	NF. 3221 Nutrition	2(2-0-0)
	NF. 3222 Diet therapy	2(2-0-0)
	NF. 3123 Basic Medical Care	3(3-0-0)
	NF. 3124 Infection Prevention control	1(1-0-0)
	NF. 3125 Communication in Nursing	1(1-0-0)
	NF. 3326 Nursing Administration	2(2-0-0)
	NF. 3327 Epidemiology	1(1-0-0)
	NF. 3228 Public Health Sciences	2(2-0-0)
Professional Nursing Course	NU. 3229 Basic in Nursing 3	3(1-2-3)
	NU. 3230 Basic in Nursing 4	3(0-0-9)
	NU. 3131 Mother and Child Nursing 1	2(1-2-0)
	NU. 3232 Mother and Child Nursing 2	2(1-0-4)
	NU. 3233 Mother and Child Nursing 3	2(1-0-4)
	NU. 3334 Mother and Child Nursing 4	2(0-0-8)
	NU. 3235 Pediatric Nursing 1	3(3-0-0)
	NU. 3236 Pediatric Nursing 2	3(0-0-9)
	NU. 3237 Adult Nursing 1	2(2-0-0)
	NU. 3238 Adult Nursing 2	2(0-0-8)
	NU. 3239 Adult Nursing 3	2(2-0-0)
	NU. 3340 Adult Nursing 4	2(0-0-8)
	NU. 3341 Adult Nursing 5	2(2-0-0)
	NU. 3342 Adult Nursing 6	2(0-0-8)
	NU. 3243 Community Health Nursing 1	2(2-0-0)
	NU. 3344 Community Health Nursing 2	2(2-0-0)
	NU. 3345 Community Health Nursing 3	3(0-0-9)
NU. 3346 Mental Health and Psychiatric Nursing	3(3-0-0)	
Elective Course	El. 3347 Computer	2(0-4-0)
	El. 3248 French	2(0-4-0)

Project	P. 3349 Project Study	4(2-0-6)
Total credits		107

Graduation

In Lao PDR, there is no licensing system for nurses based on national qualified examinations. After graduation from the course, graduated nurses can obtain the qualification of nurse. Only the community midwife and higher diploma of midwifery have a national examination and if passed, a qualification is issued. In the nursing course, the graduation certificate is issued based on the results of the examination of all subjects including theory, demonstration, and practice and project study. The contents of the examination are dependent upon subject teachers and the examination style is combined by multiple choices, essay, matching, true or false. Then the CGPA (Cumulative Grade Point Average) is used. The criterion of graduation is 2.00 (CGPA) as a minimum requirement. There is no system to ensure the quality of the examination. Plan for a national licensing system is being considered.

Qualification of Nurse Educators (current and expected)

Teachers Qualification

Regarding full-time teachers, their educational background is required higher level than teaching level however in some public health school there are some teachers who are low level midwifery-nursing. When it comes to visiting teachers, provincial hospital staff is the main resource and they account for approximately 70-80% of all visiting teachers. Medical doctors with a bachelor degree, master or above are largest number among visiting teachers at the hospital and take general and professional fundamental subjects as well as professional subjects. By contrast, nurses with bachelor degree are few at hospital and it can be said that many of nurses with a bachelor degree are working at school, college and university.

Table 5. Number of staff

Name of Institution	No of Total staff	No of staff on study leave	No of existing staff	Teaching staff (also work for admin)	No of admin staff	No of visiting teachers
Faculty of Nursing Sciences, UHS	45	4	41	34	7	80
Luangprabang College of Health Sciences	44	5	39	21	18	46
Savannakhet College of Health Sciences	34	6	28	19	9	44
Champasack College of Health Sciences	38	6	32	28	10	82
Oudomxay Public Health School	26	5	21	20	1	69
Xiengkouang Public Health School	23	7	16	12	4	46
Khammuan Public Health School	33	6	27	22	5	21
Salavan Public Health School	12	1	11	8	3	48
Vientiane Nursing school	19	2	17	14	3	28

Table 6. Teachers' Qualification

Name of Institution	Master nurse	Bachelor nurse	Diploma nurse	Technical nurse
Faculty of Nursing Sciences, University of Health Sciences	8	10	0	3
Luangprabang College of Health Sciences	5	8	0	0
Savannakhet College of Health Sciences	4	2	0	4
Champasack College of Health Sciences	3	8	0	11
Oudomxay Public Health School	1	3	3	9
Xiengkouang Public Health School	2	5	0	11

Khammuan Public Health School	0	3	3	13
Salavan Public Health School	0	1	0	1
Vientiane Nursing school	0	6	0	10

In the health personnel development strategy plan, the MOH will strengthen and build capacity of health professional education institutions and upgrade the skills and knowledge of health professional teachers and technical officer nationwide. These efforts will include: 1) Formulation of annual plan on HRH capacity building of health personnel teachers and health personnel students; 2) Revision of curriculum to focus on essential competencies; 3) Strengthening the Complex Hospital Institution Project University (CHIPU); 4) Strengthening health personnel training in rural areas aiming at improving the quality and effectiveness of health care services.

Capacity building of technical officers

Target to be achieved by 2015. By 2015, technical officers will be upgrade as follow: 1) Educational background: at least 70% of technical officers would have attained high school educational background; 2) Professional background: technical officers with post graduate degree: 50% of technical officers of the Ministry, central hospital, university and institution; 27% of regional/provincial hospital and public health colleges; and 15% of public health schools. Reduce number of unqualified health personnel by upgrading their qualification to diploma or higher diploma; 3) Foreign language ability: able to read, listen, writing and discuss at least 1 language:25% with basic level and 12% with intermediate level; and 4) At least 2 years working experience in rural area; 5) Should have 60% of female health personnel, 18% of ethnic minorities and 0.8% of disabled officers.

Demand and supply of nurse educators

The classification of staff based on professional disciplines is clustered into four major areas, as follows: Medical Doctor and Dentist; Nurses and Midwives; Paramedical and allied health staff; Professional, managerial and support staff.

Nursing, Midwifery staff will include:

- Nurses with graduate and higher degree qualifications (Bachelor Nurses and beyond)
- Nursing Clinical Specialist determined by the MOH according to service needs (such as, Medical, Surgical, Pediatric, Intensive care, Community, Mental Health etc)
- Registered Nurses (higher diploma)
- Registered Midwives (Normally RN with Post Basic qualifications in Midwifery) and Community Midwife (Direct entry or retrained Auxiliary Nurses)
- Nurse Technicians (to be upgraded over time to RN)
- Auxiliary Nurses (to be upgraded to mid level categories such as Community Midwife)

Recruitment and distribution of health personnel

The Ministry of Health will make priority for recruitment and distribution of health personnel in accordance with legislation, government regulations and other relevant decrees.

Targets for recruitment and distribution of health personnel

Target to be achieved by 2015: Achieve recruitment of 1,041 new health personnel annually. Health centers should have at least 50% mid level health personnel including a midwife, nurse and/or medical assistant and high diploma health personnel to respond to emergency obstetric and new born care.

Nursing Training Course

Post-graduate education

At present time, the post-basic nursing course is not introduced, but the qualified nurses have the opportunities of going abroad for specialization after showing good aptitude and interest in their work. The Ministry of Health has given opportunities to a number of nurses to go to abroad (Thailand, Singapore, Japan, and India) to specialize in various fields of nursing under the technical cooperation programs, such as:

Special course training (non-degree): Pediatric nursing, Adult nursing, Geriatric nursing, Community health nursing, Basic medical care, Psychiatric nursing, Adult critical care nursing, and Obstetric nursing

Master degree of nursing: Nursing administration, Nursing education, Pediatric nursing, Adult nursing, Advance obstetric nursing, Geriatric nursing, Public health nursing, Family nursing, and Psychiatric nursing

Research development

At present, the nursing research is not widely engaged. There is only thesis of master degree graduation. The main constraints of research development are: 1) Lack of qualified faculty members (bachelor, master degree nurses, 2) Insufficient faculty competence in conducting individual research and in collaborating with other discipline, and 3) Financial resources available for nursing or health research are inadequate.

Challenges of AEC for nursing education

The Main Challenges:

Faculty Challenges: Shortages of qualified nursing instructors, Language issues, and Diversity in Nursing.

Nursing educational strategies: Deficiencies in the quality of education and training of nurses; Lack of educational monitoring and evaluation (Nursing Educational Quality Assurance); Deficiencies in infrastructure: classroom,

demonstration room, equipment (teaching, practice equipment in the school should be similar to the hospital); IT challenges; teaching-learning models changing; Academic policies/procedures

Clinical Challenges include: Fewer Clinical Placement Opportunities; More students = more demand; Shortages of qualified clinical instructor-Unit Fatigue;The theory and practice do not link

Employment Challenges: Insufficient quota to recruitment new staff

References

- JICA. (2010). “Lao People` s Democratic Republic Project of Medical Education and Research for Setthathirath Hospital Final Report”. Vientiane Capital:JICA
- Ministry of Health.(2007). “Executive Summary of Sixth Five-Year Health Sector Development Plan”. Vientiane Capital: MOH.
- Ministry of Health. Department of Organization and Personne. (2008). “Nursing and Midwifery Regulations”. Vientiane Capital: Department of Organization and Personnel.
- Ministry of Health. Department of Organization and Personnel. (2009). “Higher Diploma of Nursing Program”. Vientiane Capital: Department of Organization and Personnel.
- Ministry of Health. Department of Organization and Personnel. (2011). “Health Personnel Development Strategy By 2020”. Vientiane Capital: Department of Organization and Personnel.
- Department of Organization and Personnel. Ministry of Health. (2012). “Handbook of Health Professions and Educational Program in Lao PDR”. Vientiane Capital: Department of Organization and Personnel.
- Ministry of Health. (2008). “2008-12 SBA Development Plan of Lao People` s Democratic Republic”. Vientiane Capital: Ministry of Health.

NURSING SERVICES IN LAO PDR

Lamngeun Silavong

Nurse Supervisor, Nursing Department, Mahosot Hospital

Country background

Lao People's Democratic Republic (Lao PDR) situation: The Lao PDR is a small country located in the South-East Asia with an area of 236.800 square kms. The Lao PDR is a land locked country sharing its borders with the other countries as: an Eastern border with Vietnam, a western border with Thailand, a southern borders with Cambodia, a Northern border with China and Myanmar. Although Lao PDR is has no access to the sea. The forest, which covers approximately 47 percent of the country, consists of wide variety of species, including an abundance of valuable hard woods. Lao PDR has 16 provinces and plus Vientiane city, 138 distcits, 11.640 villages. 15% of the population is living in urban and 85% in rural area. The agriculture production is low and scattered. The population of approximately 6.385.057, life expectancy at birth 64.7 Number of Medical Practitioners Total 21.000, Post Graduate 1.400, Doctor 3.800, Physician 7.500, Physician Assistance 7.900, (Ministry of Health 2011), The major public health problem are malaria, dengue, acute respiratory infection, gastro - enteritis, maternal and child emergencies. Traffic accident, sexually transmitted diseases (STD) including HIV/AIDS and diseases related to smoking and excessive alcohol consumption are increasing.

Health care need and Nursing needs

Both of health-care and nursing care need to improve the quality of care and the accessible and affordable to population. Lao PDR has made great progress to promote health care service to the Lao people, nationwide. During 35 years after the revolution, there is evidence of increases in health awareness of the populations, resulting improvement of the situation system, family planning coverage, HIV/AIDS and sexual transmitted diseases prevention, identification and treatment of tuberculosis case and utilization of treatment mosquito bed net. The health care utilization also has been continually increasing. The major achievement includes, 67% immunization coverage and 95% coverage of measles vaccination during mass.

Health Care and Nursing Systems

Health care system

The health-care system of the Lao PDR comprises of 1) the public health-care system, and 2) The private health-care system

The public health-care system

There are four levels to the public health-care systems: Primary health-care services, Intermediate level health-care service, High-level health-care services, and Advance health-care service.

Primary health-care services correspond to the medical care provided by the village drug kits and health centers. The village drug kits are premises on which essential drugs are available and which provide medical care for the population of village in which there are no health centers. Village drug kits are staffed by village assistant physicians or village public-health volunteers and traditional birth attendants and possess basic medical instruments. They provide drugs and offer consultations and treatment for benign seasonal illnesses and in particular diarrhea, malaria, flu and minor wounds. They also assist with home births. A health center is a public place providing treatment in a village and which possesses consultation rooms, and accommodation, which is staffed by a

physician, an assistant physician, nurses and midwives and which possesses basic medical instruments and materials and is able to provide essential procedures and techniques. Health centers are able to provide consultations and higher-level treatment than that provided by the village drug kits, such as treatment for chronic diarrhea, prolonged flu, wound suture, vaccination and assistance with childbirth.

Intermediate level health-care service corresponds to the medical care provided by the district and municipal hospitals. District and municipal hospitals are staffed by physicians and assistant physicians, dentists and assistant dentists, nurses, midwives and medical technicians. they possess medical material and equipment and employ the necessary techniques and technologies. there are responsible for providing consultations and treatment in the four basic disciplines: medicine, surgery, gynecology obstetrics and pediatrics.

High-level health-care services correspond to the medical care provided by the provincial and regional hospitals. Provincial and regional hospitals are staffed by physicians, dentists, nurses, midwives and the different medical technicians. They possess medical material and equipment and employ modern procedures and techniques. They are capable of providing consultations and higher-level treatment than that provided by the district and municipal hospitals.

Advance health-care service correspond to the medical care provided by the central hospitals and specialized care centers. Advance health-care services are staffed by specialists, physicians, dentists, nurses, midwives and the different medical technicians. They possess medical material and equipment and employ modern procedures and techniques. They are capable of providing consultations and higher-level treatment than that provided by the provincial and regional hospitals.

The private health-care system

The private health-care system comprises private hospitals, clinics, physiotherapy practices, saunas, traditional massage practices and traditional medicine practices. Private hospitals, clinics, physiotherapy practices, saunas and traditional massage practice much possess medical facilities, staff, material and

equipment and employ procedures and technology in accordance with the regulations of the Ministry of Health Clinics:

A health-care professional may have only one clinic, which he may neither rent out nor lend. If the health-care professional authorized to operate the clinic dies or is unable to practice, no other person may practice in it without the prior authorization of the Ministry of Health.

Nursing system

Nursing system is supervised by nursing unit, Ministry of Health, in accordance with Nursing and Midwifery Regulation, Guidelines for scope of nursing practice, Guidelines for scope of midwifery, Clinical standard of midwife practice. Regarding nursing services, the nursing unit developed job description of head nurse and staff nurse who worked at hospitals. The Ministry of Heal has been making efforts to develop competency regulatory framework. As the first step, National Competencies for Licensed Nurse was established in 2013. The total number of health personal is 21.000 people are deployed at the central level 1.33% level at the provincial prefecture 48.7% at the district level and below 2.1% are on study leave within Lao PDR and in foreign countries.

Table 1. Total Number of bed in Lao PDR

Item	Unit	2011	2012
Central hospitals	beds	856	840
Curative Centers at central level	beds	120	120
Regional hospitals	beds	675	675
Provincial hospitals	beds	930	930
District hospitals	beds	1 845	1 859
Dispensaries	beds	2 281	2 280
Total	beds	6 707	6 704

The major public health problems are malaria, diarrhea, dengue, tuberculosis, acute respiratory infection, gastro-enteritis, maternal and child emergencies, Traffic accident, sexually transmitted diseases (STD) including HIV/AIDS and diseases related to smoking and excessive alcohol consumption is increasing.

Table 2. Level of nursing staff including level of Education, Competency, etc

Category	Entry requirement	Length of training	Level
2 years program for nursing /midwifery	11 years school	2 years	Certificate low level
Registered or Diploma nursing /midwifery	11 years school	3 years	Diploma middle level
Technical nurse	11 years school	2.5 years	Diploma middle level
Bachelor of nurse	12 years school	2.5(CE)/ 4 years(DE)	Bachelor of nursing

Demand and Supply of Nursing Staff

Target for recruitment and distribution of Health personnel.

Target by 2015: Achieve recruitment of 1,041 new HP annual; at health center level should have at least mid-level HP. HP at health center level should include midwife, nurse or medical assistant, and high diploma medical HP to respond to emergency obstetric and newborn care.

Targets by 2020:

Continue to recruitment of 1,136 new HP annually

Health center level should be staffed with mid level PH including; midwife, nurse or medical assistant, and high diploma medical HP to respond to emergency obstetric and new newborn care.

Utilization of multi-discipline HP at district hospitals and health centers such as family doctor, high diploma and diploma HP and PHC practitioners

Expand health system network through outreach medical team from central level, provinces, districts and health center as well as international experts in communicable disease surveillance, natural disaster, health promotion, health check-up, treatment and on-site training for rural and remote HP.

Continue to produce and upgrade HP in specific areas focusing on gaps such as integration of PHC and resuscitation.

Licensing

Developing Licensing system is one of urgent needs for the Ministry of Health in order to regulate quality of health care professional under Health Care Reform linked with Integration of ASEAN economic community. Ministry of Health established

Nursing staff development/Training course include: Improving knowledge, Short Course Training (Local and Overseas), Long Term Study (Local and Overseas)

Research development

Areas of research: Clinical Research, Health System Research (focused on healthcare delivery quality), Bio-medical Research, Collaboration institutions, International and regional research collaboration (Wellcome Trust, SEATCA), Outstanding national research projects (STEP Survey on NCD risk factors, Tobacco related diseases etc), End of course research projects carried out by fellows, residents, medical students supervised by our staff.

Challenge of AEC for nursing services include: ASEAN Mutual recognition Arrangement on Nursing, Review nursing and midwifery competency, Set up registration system for nurses and midwives, Set up national examination for

nurses and midwives, Licensing system on nursing and midwifery, and Establish regulatory body for nurses and midwives

References

Ministry of Health. (2006). “Law on health care”. Vientiane Capital: MOH

Ministry of Health. Department of Organization and Personnel. (2010). “Health personal Development Strategy by 2020”. Vientiane Capital: MOH

The Workshop on Nursing and Midwifery in Southeast Asia. (2012). “National Center for Global Health and Medicine”.

NURSING EDUCATION IN MALAYSIA

*Associate Professor Khatijah Lim Abdullah, Ph.D.
Head of Department of Nursing Sciences, Faculty of Medicine,
University of Malaya*

Introduction

In the 50 years since Malaysia became an independent nation, it has undergone enormous change. Impressive skyscrapers and luxury resorts sit adjacent to shantytowns. Malaysia is a multicultural melting pot, with half the population being Malay, almost one fourth Chinese, 11% indigenous and 7% Indian (Central Intelligence Agency 2007).the state religion of Malaysia is Islam, although the constitution ensures freedom of workshop. This provision is essential in a country of such cultural diversity. The role of Syariah courts in controlling issues pertaining to Islamic faith is nonetheless enshrined in the constitution of Malaysia (Economic Intelligence Unit 2006). Malaysia is moving towards a developed country status and it is imperative that the healthcare provided be at a higher standard than it is today. As members of the healthcare team, nurses play an essential role in the provision of healthcare. As such it is timely that nurses' education be upgraded.

Nursing in Malaysia

The nursing workforce in Malaysia is composed almost exclusively of women. Although the number of male entering a career in nursing is increasing, men currently represent less than 0.3% of the total nursing workforce (ICN 2006).

Nursing , however, is not held in high regard as an occupation with many parents discouraging their children from pursuing this as a career. Often the women will enter a career in nursing because the current system offers them a chance to move away from home. Most hospitals provide accommodation and an allowance during the period of training. In most cases these graduates are bonded to their training hospital for a period of up to 5 years.

Development of nursing education

Nursing in Malaysia, along with the health system generally, evolved from and has remained similar to the British system that was introduced during the colonial times. Malaysia nursing education began in hospital based settings like most other countries. Before the enactment of the Nurses Act (1950) three regional school of nursing were established: School of Nursing Hospital Johor Baharu (1946), School of Nursing Hospital Pulau Pinang (1947) and School of Nursing General Hospital Kuala Lumpur (1948). All the three schools were headed by English tutors. At this time, education of nurses was based on the job training approach where lectures were given by the matron, ward sisters and doctors. In 1952, the training became more formalised using a curriculum based on the General Nursing Council (GNC) of the United Kingdom. The block system curriculum was adopted comprising of 20% theory an 80% practicum for the duration of 3 years and 4 months. The ultimate aim of the training at this point in time was to obtain reciprocity with hospitals in England and Wales to enable Malaysian nurses to continue their studies in countries abroad that have reciprocity with England and Wales. During this period, many nurses were sent for nurse tutor course.

The first private school of nursing was the Tun Tan Cheng Lock School of nursing established in 1967 at the Assunta Hospital PJ. In 1968 the first teaching hospital, University Hospital, School of Nursing Kuala Lumpur was setup. Both schools were subjected to the 1950 Nurses Act regulations and procedures. Up til 1992, the graduates of nursing program on passing the final nursing board exam

receive a certificate in general nursing. By late 1992 the certificate curriculum was upgraded with more theoretical input (up to 50%) to become a diploma curriculum. Year 1993 marked the beginning of tertiary education for nursing. The first university program started in 1993 at the University of Malaya, admitting diploma graduates to prepare them to be nurse educators and nurse administrators. It was a 3 year program awarding a Bachelor of Nursing Science (BNSc) with honours.

In 2003, the Quality Assurance Division, Department of Higher Education, Ministry of Higher Education (MOHE) through a high level committee including member of the Nursing Board develop guidelines for a 4 year Bachelor of Nursing (Hons). Currently at least seven public universities are conducting the 4 year program : University Malaysia Sarawak (UniMas), University Science Malaysia (USM), University Putra Malaysia (UPM) , International Islamic University (UIA), University Technology Mara (UiTM) , National University Malaysia (UKM) and university of Malaya (UM).

The 21st century also mark the beginning of the establishment of the postgraduate program in nursing at various public institution namely University of Malaya, University Technology Mara (UiTM), National University Malaysia (UKM). The emphasis on postgraduate education in nursing must be clinical to enable graduate to use the content and experience as experts in order to be able to teach at undergraduate level and also to manage acute care institution. This clinical postgraduate nursing education is seen as another positive milestone for nursing. Being a practice profession, nursing must be practiced by nurses at all levels. The three public universities offer Masters of Nursing degrees in various specialities for example Critical Care, Mental Health, Community Health, Orthopaedics and Trauma from UKM, while UiTM only offer Women Health and Critical Care. University of Malaya offer their students most of the specialities depending on the availability of the clinical supervisors and the clinical facilities. Several private institutions of higher learning, namely MAHSA University

College and Open University Malaysia (OUM) offer nursing related courses at Masters level.

The latest development in nursing records the following events :

At the end of year 2008, there were about 70,000 nurses registered with the Nursing Board. The nurse patient ratio was 1:375 where the target by 2015 should be at least 1:200 to meet the standards set by the World Health Organisation (WHO). There were 17 public colleges of nursing, 10 public universities and 54 private colleges. Together, they produced 6000 diploma graduates (2500 from Ministry of Health and 3500 from private colleges).

By 2009, the number of private colleges has increased to 70 and the number of graduates has been doubled (12000 including community nurses). By the end of 2009 there were nearly 80000 nurses in the country.

These events lead to the question whether it increases fix the shortage and add to the improvement of health care. In response to the concerns raised in regards to the quality of the graduates , the Ministry of Higher Education in 2010 stated that ‘ the mushrooming of private nursing colleges will soon be a thing of the past. Applications to set up new institutions will not be accepted.’ He continued to say that institutions of higher learning should concentrate more on degree courses. A moratorium was placed on new nursing courses and institutions so that importance can be placed on the quality of the courses and the performance of students.

Nursing curriculum

As we all know to be classified as a profession, the first criterion is for nursing to have an extended education for its member as well as a basic foundation. Guidelines in curriculum design for a four year Bachelor of Nursing (Hons) was developed in 2003, spearheaded by the Quality Assurance Division, Department of Higher Education, Ministry of Higher Education. The members involved comprised of nursing members of public and private universities

The proposed curriculum design is comprehensive yet proportionately balanced between three major sciences (Medical sciences, nursing sciences and social sciences).

Basic Medical Sciences	15-20%
Core Nursing Sciences	55-65% of which 45-50% must be practicum
Humanities and Social Sciences	15-25%
Scientific (research)	4-7%
Electives	2-7%

The entry requirements for the Bachelor of Nursing include Sijil Tinggi Pelajaran Malaysia (STPM) which is equivalent to the ‘A’ level or matriculation or its equivalent with minimum pass in Biology and Chemistry or Biology and Physics or a recognised diploma in nursing with transfer of credits to the appropriate level of a four year programme AND credits in Mathematics and Bahasa Malaysia at Sijil Pelajaran Malaysia (SPM) level and Malaysia University Entrance Test (MUET) Band 3 or 4.

These standards and criteria including those of the Malaysia Qualification Framework (MQF) mark the beginning of an upgrading of nursing education in Malaysia. These have helped placed nursing at par with other professional programs such as medicine, dentistry, pharmacy , where pure sciences became the major criteria for admission. These standards and criteria mark the beginning of a true upgrading of nursing education in Malaysia. The entry requirements have placed nursing at par with other program such as medicine, dentistry, pharmacy where pure sciences subjects became the main criteria. The current scenarios in faculties of medicine where both nursing and medical students co exists and where sharing of resources is inevitable, the outcome not only competitive but also synergistic in nature.

The importance of pure sciences is unquestionable. Nurses are confronted with numerous literacy, scientific issues at every facet of their professional life for example in the implementation of nursing process for both degree and diploma programmes. In Malaysia there are two education preparations for registered nurse: diploma and bachelor of nursing. In addition, there are post basic courses, continuing and in service education for practicing nurses.

Diploma program

All the colleges that conduct the diploma in nursing programme follow the requirements stipulated by the Nursing Board of Malaysia, which comprises the following: 1) Total credits of 90-110 in three years based on the credit system ie 14-16 hours of face to face teaching hours; 2) Curriculum components must consists of three (3) core sciences: Nursing Sciences (60-80%), Health Sciences (10-20%) and Behaviour Sciences (10-20%) . in addition there must be at least be 45-55% theory and 45-55% practical; 3) Student assessment; continuous assessment (30-40%) and summative (60-70%) in the form of exam; and 4) Practical log.

It should be noted that the Nursing Board Malaysia also establishes the criteria or standards for nursing training. Their five major functions include: Development of syllabus and curriculum for the Basic Nurse Training; Regulation for the conduct of final examination; The Regulation to control the practice of nursing through registration and issue of Nursing Registration Certificate and Registration Badge; and Annual Practicing License (introduced in 1998)

Post basic courses

For more than 25 years, the Ministry of Health has offered excellent post basic courses ranging from six months to one year, in all aspects of clinical nursing. This certificate has been widely accepted by universities as part of entry requirement into the degree programme or meeting conditions fro clinical requirement in the academic setting.

The Degree Program

The Department of Public Services (JPA) is expecting a degree nurse to function in the clinical setting , not just teaching and managing. A degree nurse is also a first line nurse. She is a skilful nurse, someone who is able to assess what patient needs and plan for care with the full knowledge of all other aspects (such as psychologically and social components) and to do it in a caring way. It is the ability of the nurse to be a critical thinker, to work well in a team and to think on her feet that makes a difference. The student should be assessed in clinical knowledge, clinical competence and clinical performance. Clinical knowledge can be assessed through objective ad subjective written examination whereas clinical assessment can be assessed through objective structured clinical examination (OSCE) . clinical effectiveness can be assessed through giving direct care to a patient using technical procedures and nursing process. Skills assessed include management, communication, team capabilities, leadership skills in addition to basic nursing skills. All the clinical assessment must be clinical based and student must have direct access to a regular clinical setting, where continued learning can occur. This mean the college or university msut be attached or an affiliate of a hospital with at least 250 beds as specified by the Higher Education Department.

Teacher qualification

To teach in a diploma programme , the nurse teacher needs a nursing degree and a specialised area of nursing. Teaching skills qualification must be obtained as an addition requirement. Similarly to teach in a degree programme, the lecturer must have at least a masters degree with teaching skills qualification. MQA advocates the use of content experts for each course/subject or content area. Thus a lecturer with a Bachelor of Nursing and a Masters degree in education for example, is nt qualified to teach mental health nursing unless she has in depth knowledge obtained via a post basic certificate or extensive experience in the speciality (in this case, mental health).

Graduate education

The minimum requirement for graduate education is the Bachelor of Nursing degree. Nurses can pursue graduate education leading to Postgraduate diploma, Masters degree, and Doctoral degree

Postgraduate diploma

Currently , UKM and MAHSA University College have such a programme, namely postgraduate diploma in nursing (midwifery). The programme is one yaer (two semesters) course worth a minimum of 30 credits.

Masters degree

The Masters programmes cover core courses in research (statistic and research methodologies) , nursing theories, beside the clinical speciality so that upon graduation, they can use the speciality knowledge and skills to teach, manage a facility/service and conduct research. The minimum credits is 40 credits and the duration of the program is between one to two years full time or two to four years part time.

Some of the subjects offered in the program :

Nursing Research I – Qualitative Method

Nursing Research II – Quantitative Method

Medical Statistics

Principles & Methods of Epidemiology

Statistical Computing Module

Health Assessment

Issues & Trends in Nursing & Health Care

Reflection in Nursing Practice

Health Promotion

Practicum in Nursing

Nursing Research Project I

Nursing Research Project II

Doctoral degree in nursing

The need for nurses with doctoral degrees is increasing. Expanding clinical roles, continuing demand for well educated nursing faculty and new areas of nursing specialities, and the need to conduct research in nursing are some of the reasons for increasing the number of doctorate nurses. The department of higher education has clearly stipulated that by 2020 there should be 30-50% PhD holders in a nursing faculty.

In nursing, there are two ways in which nurses can gain a doctoral degree: one is through professional doctoral programmes eg Doctor of Nursing Science (DNS). The programme prepares graduates to apply research findings to clinical nursing. At present only Open University Malaysia (OUM) offers such program. Most of the public universities offer the traditional Phd by research which emphasises more basic research and theory.

Other educational programmes

The Nursing Board of Malaysia in 2007 had produced 'Guidelines on Standard and Criteria for Approval of Nursing Programmes' and one of the programme mentioned was the 'Post Registration Degree'. The Post Registration degree programme has 80 credits and admits diploma graduate for two years full time. This programme is mostly offered by private institutions which include Open University Malaysia (OUM), MAHSA University College, Masterskill University College, and SEGI University College. It should be noted that the post registration program offered by the University of Malaya in 193 till 2010 differed from the current post registration offered by the current institution. This is due to the fact that it was offered at a time when the duration of a undergraduate degree program was 3 years. It also had a different program objectives whereby the students graduated with a major either in teaching, management or clinical speciality. This is made possible due to the admission criteria that required a 6 months post basic course in addition to diploma in nursing.

Research development

The Department of Nursing Sciences has set up a Research and Innovation Unit to look into research and publication. The University has several research clusters - one of which is Health and Translational Medicine. Within this cluster there are different centres: Centre Of Excellence Research in AIDS (CERIA); Centre for Population Health (CePH); Centre for Clinical Epidemiology and Evidence -Based Medicine (Julius Centre); Oral Cancer Research And Coordinating Centre(OCRCC); UM Eye Research Centre (UMERC).

All academic staff must register to one of the different centres. Promotion incentives are based mostly on number of publication and the amount of grant. As for the masters students' research project, they are required to prepare manuscript and submit for publication. Evidence of acceptance of at least 2 ISI articles is a requirement before they can submit their thesis for assessment.

Challenges of AEC for nursing education in Malaysia

Training quality

For many years now, the production of nurses has become a competitive venture among businessmen. The nursing shortage is being seen as a number game. However, the question is, will these numbers add to the improvement of healthcare, or the caring that nurses have been entrusted by society to provide. Nursing's plan must include the notion that by 2012, all universities must cease to prepare diploma graduates and that only recognised colleges with affiliate hospitals will continue to prepare nurses. The number of graduates must be determined based on future service requirement.

Conclusion

There is a need to have a paradigm shift in nursing education. For as long as the entry into nursing service remains at diploma level, leadership will evolve from these diploma graduates, and the outcome of changes made will remain at diploma thinking level. Nurses in leadership positions arising from such a system may not be ready enough to make profound, sustainable change in nursing culture.

NURSING SERVICES IN MALAYSIA

*Associate Professor Khatijah Lim Abdullah, Ph.D.
Head of Department of Nursing Sciences, Faculty of Medicine,
University of Malaya*

Introduction

The Malaysian population is estimated to be 28 billion and the area of Malaysia is 330,000 Km². For health care system of Malaysia, universal healthcare system co exists with private health care system. Hospitals have three types including general hospitals, district hospitals, and special medical institutions. There are 20 general hospitals averaging 600 - 1,000 beds each. Moreover, health clinics are categorized into six types according to number of beds in the following Table 1.

Table 1. Health clinics according to number of beds

Health Clinics	Type 1	Type 2	Type 3	Type 4	Type 5	Type 6
Work load (Number of beds)	800	500-800	300-500	<300	<150	>50

Nursing staff in Malaysia

Nursing staff in Malaysia comprises of public sector and private sector. The most registered nurses and nurses with specialization have been worked in

public sector. Number of registered nurses and nurses with specialization in each sector is shown in Table 2. Moreover, there are information regarding number of foreign nurses working in Malaysia and it is shown that number of those is fluctuation as Table 3.

Table 2. Number of Registered nurses and number of nurses with specialization in Malaysia

Description	Number of Registered Nurses	Number of nurses with specialisation
Public sector	46,254	21,814 (49%)
Private sector	23,251	1,192 (5.1%)
Total	69,505	23,006 (33.06%)

Table 3. Number of foreign nurses working in Malaysia

Year	2002	2003	2004	2005	2006	2007	2008	2009	2010	2011	2012 (Feb.)
Number of foreign nurses	549	635	538	555	740	856	1,052	1,317	1,011	852	834

Nursing Personnel:

Each state has a state matron assisted by general hospital or district hospital matron, and each ward in a hospital has a ward sister and staff nurses. Majority are diploma trained nurses and female. The information of nursing personnel showed that less than 5% of those are degree trained nurses and less than 2% of those have master degree. In addition, less than 1% of nursing personnel has doctoral degree.

Nursing Board Malaysia (NBM):

The agency that establishes criteria or standards for nursing training is nurse act in 1950 and nurse registration regulations in 1985. The aims are 1)

standards and professional conduct, 2) policy device, and 3) developing and promoting patient care.

Nursing Board Malaysia is responsible for curriculum guidelines, curriculum accreditation, registration, examination, and practice certificate. For functions of NBM are 1) training that includes approval and accreditation, 2) registration, 3) discipline, 4) examinations, 5) annual practice certificate/ license / retention, and 6) professional conduct.

Guidelines on standards and criteria have eight standard including governance and management, programme resource, human resources, the curriculum, admission policy, student assessment, programme evaluation, and continuous improvement activities.

Legislation

Nurses Act and Nurses Registration were established in 1950 and then Nurses Registration Regulations and the Annual Practicing Certificate (APC) was implemented in 1985.

Malaysia Qualification Framework (MQF): as the following Table 4.

Table 4. Level of Qualifications

MQF levels	Qualifications	Minimum credit
8	Doctoral	No given credit value
7	Research Masters	No given credit value
	Fully or partly taught Masters	40
	Postgraduate Diploma	30
	Postgraduate certificate	20
6	Bachelors	120
	Graduate Diploma	60
	Graduate Certificate	30
5	Advanced diploma	40
4	Diploma	90

MQF levels	Qualifications	Minimum credit
1-3	Certificate Skills certificate	60 According to skills and levels

Issues

For nursing services, the most of nursing personnel in Malaysia have graduated in diploma (less than 5% are trained nurse, less than 2% has master, and less than 1% has Ph.D.)

NURSING EDUCATION IN MYANMAR

Daw Aye Nyunt
Assistant Director
Executive Member of Myanmar Nurse and Midwife Council
The Republic of the Union of Myanmar

Abstract

Nursing service is an integral part of the health care. The efficiency and capability of nurses and midwives is important for delivery of quality health care to the population. In Myanmar, the training of nurses began since 1922 with a curriculum. The curriculum was reviewed and revised regularly and constantly to meet the current health needs and demands from the society and the country, under the guidance of the Ministry of Health and the Department of Medical Science is mainly responsible for it. The Institute of Nursing, Yangon, with the aim to produce qualified and competent nurses, was established in 1991 and started producing the B.N.Sc (Bridge) graduates. There was also the faculty development programs in order to keep nursing education and training in harmony with the changing health care system and to improve Myanmar nursing education system in line with the regional and international nursing standard as well as nursing practice. With recent advances in biomedical sciences and Medical Technology, capacity building for educators is needed from time to time in order to provide high quality nursing education and service.

Introduction

The Republic of the Union of Myanmar is the largest country in South-East Asia, located on the Bay of Bengal and Andaman Sea. It is bordered on the east and north-east by the Lao People's Democratic Republic and the Kingdom of Thailand, on the north and north-east by People's Republic of China, on the north west by the Republic of India and on the west by the People's Republic of Bangladesh. Myanmar covers an area of (676,578) square kilometers of Indo-China peninsular. It lies between 09°32' N and 28°31'N latitudes and 92°10' E and 101°11' E longitudes. It stretches 2200 kilometers from north to south and 925 kilometers from east-west at its widest point. It is approximately the size of France and England combined. Myanmar is bounded by Bangladesh, India, China, Laos and Thailand on the landward side, 1760 miles of the coast line is bounded on the west by the Bay of Bengal and on the south by the Andaman Sea.

The country is divided administratively, into Nay Pyi Taw Union Territory and (14) States and Regions. It consists of (70) Districts, (330) Townships, (84) Sub-townships, (398) Towns, (3063) Wards, (13,618) Village tracts and (64,134) Villages. Myanmar falls into three well marked natural divisions, the western hills, the central belt and the Shan plateau on the east, with a continuation of this high land in the Tanintharyi. Three parallel chains of mountain ranges from north to south divide the country into three river systems, the Ayeyarwady, Sittaung and Thanlwin.

Myanmar has abundant natural resources including land, water, forest, coal, mineral and marine resources, and natural gas and petroleum. Great diversity exists between the regions due to the rugged terrain in the hilly north which makes communication extremely difficult.

The population of Myanmar in 2011-2012 is estimated at 60.38 million with the growth rate of 1.01 percent. About 70 percent of the population resides in the rural areas, whereas the remaining are urban dwellers. The population density

for the whole country is 89 per square kilometers (Ministry of Health (MoH)2012 pg. 2-3).

Myanmar Health Care System

Myanmar Health Care System evolves with changing political and administrative system and relative roles played by the key providers are also changing although the Ministry of Health remains the major provider of comprehensive health care. It has a pluralistic mix of public and private system both in the financing and provision. Health care is organized and provided by public and private providers (MoH, 2012.pg.6).

Nurses and Midwives are largest in number among all categories of health personnel in the health sector. The efficiency and capability of nurses and midwives is important for delivery of quality health care to the population. The training of nurses began since 1922 with a curriculum. The primary focus of the educational process is the health of the community. The curriculum is drawn especially for the purpose of promotive, preventive, curative and rehabilitative health care in the clinical setting (Department of Medical Science (DMS, 2010.pg.1)

Ministry of Health/ Health Organization

The Ministry of Health is the major organization responsible for raising the health status of the people and accomplishes this through provision of comprehensive health services focusing on promotive, preventive, curative and rehabilitative measures.

The Ministry of Health has eight functioning Departments headed by Director General. They are Department of Health Planning, Department of Health, Department of Medical Science, Department of Medical Research (Lower Myanmar), Department of Medical Research (Upper Myanmar), Department of Medical Research (Central Myanmar), Department of Traditional Medicine and Department of Food and Drug Administration. All these departments are further

divided according to their functions and responsibilities. Maximum community participation in health activities is encouraged. Collaboration with related departments and social organizations has been promoted by the ministry. Considering health sector as a whole the MoH is strengthening the Public private partnership for health development. The ministry also has close collaboration with other sectors to take into account issues that are beyond the scope and capacity of the health sector.(MoH, 2012, pg.27)

Department of Medical Science

Human Resources for Health are the most important resources for successful implementation of National Health vision and mission. The Department of Medical Science is responsible for carrying out this duty of training & production of all categories of health personnel with the objective to appropriate mix of competent human resources for delivering the Quality Health services.

The Department has seven divisions which are Graduate Training Division, Postgraduate Training Division, Nursing training Division, Planning and Statistics Division, Foreign Relation Division, Administrative & Budget Division and Medical Education Centre. The Department also has one community field Training centre for practicing the community Medicine and Field Training.

Reviewing, revising and updating of educational programs and supervision of training processes for Quality assurance, management of faculty development and infrastructure development are the major activities of the Department of Medical Sciences. (MoH, 2012, pg.30).

Criteria for Selection of Basic Nursing (Diploma Students)

The criteria for selection of basic nursing diploma students are as passed B.E.H.S program attaining upper ranking in B.E.H.S Examination mainly Myanmar, English and Mathematics courses of the respective State and Region. Age limitation also set within 18 to 25 years, with good physical and mental

health. The selection criteria and policy was laid down according to the departmental requirements.(DMS.2010.pg.1).

Nursing and Midwifery Curriculum

Emergence of Curriculum Development

1922 The training of nurses began since 1922 with a curriculum, which is mainly **hospital based**, three-year general nursing program up to 1979.

1977 Due to changing trend of diseases as well as the health needs of the country the curriculum was first revised in 1977 according to the four years People Health Plan.

1980 The revised curriculum expanded to become a three and half year course, which comprised of the three years general nursing and six months of midwifery training began in 1980 up to 1991.

1992 The curriculum was reviewed for the second time which based on **community oriented** , which included some major changes to the existing curriculum.

2001 Under the guidance of the Department of Medical Science and working in collaboration with W.H.O, reviewed of the curriculum was carried out for the third time with an aim to develop a revised curriculum which is relevant to the changing health needs of the country. The curriculum was changed into three years including nursing and midwifery training.

2010 The nursing curriculum was revised for the fourth time due to changing trend of diseases and the health needs of the country (DMS,2010.pg.1).

B.N.Sc Curriculum

Objective

The primary focus of the educational process is the health of the community. The curriculum is drawn especially for the purpose of promotive, preventive, curative and rehabilitative health care in the clinical setting as well as in the community.

Course offered

a) B.N.Sc (Generic) Course

Course offered for B.N.Sc (Generic) program in first year are Myanmar, English, Chemistry, Physics, Anatomy and Physiology, Biochemistry, Community Health Nursing, Fundamental Nursing, Nursing Concept and Theory and Behaviour Science.

Pathology, Microbiology, Pharmacology, Fundamental Nursing , Maternal and Child Health Nursing, Adult Health Nursing, Community Health Nursing, and Behaviour Science subjects are taught in second year.

Maternal and Child Health Nursing, Adult Health Nursing, Community Health Nursing, Mental Health Nursing and Research subjects are taught in third year.

Maternal and Child Health Nursing, Adult Health Nursing, Community Health Nursing, Mental Health Nursing and Nursing Administration and Management subjects are taught in fourth year.

b) B.N.Sc (Bridge) Course

Course offered for B.N.Sc (Bridge) program in first year (Term I) are Myanmar, English, Chemistry, Physics, Physiology, Biochemistry, and Behaviour Science. Maternal and Child Health Nursing, Adult Health Nursing, Community Health Nursing, Mental Health Nursing and Nursing Administration and Management and Nursing Research subjects are taught in Year I Term II.

Maternal and Child Health Nursing, Adult Health Nursing, Community Health Nursing, Mental Health Nursing and Nursing Administration and Management, Nursing Research and Pathology subjects are taught in Year II

c) Diploma in Nursing and Midwifery Curriculum

Course Description

This academic program is of three years duration for basic nursing students and prepare the students for entry into professional nursing practice. It

includes selected subjects in the Biomedical Sciences to provide background knowledge and foundation for subsequent nursing courses.

The program prepares students for nursing practice at all level of health care and for both promotive and preventive purposes. Knowledge concerning nursing sciences is structured in a systematic way with emphasis on core concepts. This formal program of study is viewed as the beginning of a life long process of learning whereby students are encouraged to be responsible and accountable for their development as individuals and as nurses.

This program is organized into three levels (year one, two and three), each comprising of nursing and biomedical Science courses. Students have to complete all requirements before graduation with a diploma in nursing (DMS, 2010.pg.1).

Curriculum Content

Course offered in Year I Term I are Nursing Foundation I, Community Health Nursing I, Communication Skill, Psychology, Human Biology I, Physics and Chemistry, English and Myanmar.

Course offered in Year I Term II are Nursing Foundation 2, Community Health Nursing 2, Maternal Health Nursing I, Sociology, Human Biology 2, Nutrition I and Microbiology and Parasitology.

Course offered in Year II Term I are Pharmacology, Community Health Nursing 3, Maternal Health Nursing 2, Adult Health Nursing, Nursing Research and Nutrition 2.

Course offered in Year I Term II are Community Health Nursing 4, Adult Health Nursing 2, Mental Health Nursing I, Maternal Health Nursing 3 and Child Heath Nursing I.

Course offered in Year III Term I are Community Health Nursing 5, Adult Health Nursing 3, Child Health Nursing 2, Mental Health Nursing 2 and Maternal Health Nursing (Domiciliary).

Course offered in Year III Term II are Nursing Administration and Management, Community Health Nursing 6 and Adult Health Nursing 4. (DMS, 2010.pg.3).

Course Assessment

The student assessment consist of both formative and summative aspect, aimed at determining the student's progress as she/he under goes the designed learning experiences. A variety of assessment methods will be used. The student will be assessed at the end of each term on the subject taught during that term. The assessment of students will be weighted for courses having no clinical/ practical, Theory 70%, Class work 30% including Completion test 20% and Practical/Assignment 10%.

For courses having clinical/ practical, Theory 40%, Practical 30%,Class work 30% will put into account.

For each of the above area, the student needs to obtain 50% in one compartment (final theory or practical) in order to pass a course.

Written test will use MCQ, MSQ. Assessment tools for students in clinical/ field practice are Checklist and Observation Rating Scale.

Class work includes Case Studies, Research Studies, Term Paper, Logbook System and Written Assignment. (DMS, 2010.pg.218).

d) Diploma in Midwifery Curriculum

Recent changes not only in community health service provision within the country, but also general advances in midwifery and midwifery related subjects, must be included in midwifery curriculum to prepare competent midwives capable of meeting existing and future needs of the country. This is particularly important in Myanmar where midwives are at the forefront of health care and have a crucial role in health promotion and education.

In 2010, the midwifery curriculum was critically reviewed and was upgraded from 18 months certificate course to 2 years diploma course to meet the

needs of the nation and changing trends. The curriculum was implemented in 2012.

The revised curriculum places a greater emphasis on demonstrating competence in knowledge, skills and attitudes of midwives. These competences depend mainly upon the area of effective and comprehensive care for maternal and child health and current health information. (DMS, 2011.pg.1).

Course Description

This academic program is of two years duration for basic midwifery students and prepare the students for entry into professional midwifery practice. It includes selected subjects in the Biomedical Sciences to provide background knowledge and foundation for subsequent midwifery courses.

The program prepares students for midwifery practice at all level of health care and for both promotive and preventive purposes. Knowledge concerning nursing sciences is structured in a systematic way with emphasis on core concepts. This formal program of study is viewed as the beginning of a life long process of learning whereby students are encouraged to be responsible and accountable for their development as individuals and as midwives.

This program is organized into two levels (year one and two), each comprising of midwifery and biomedical Science courses. Students have to complete all requirements before graduation with a diploma in midwifery. (DMS, 2011.pg.1-2).

Curriculum Content

Course offered in Year I Term I are Basic Midwifery concept and standards, Basic Nursing Procedures, Essential Science including , Human Biology, Nutrition, Microbiology, Basic Pharmacology, Immediate Care and Behavioral Science.

Maternity and Essential Newborn Care, Child Health Nursing, Nursing Care in Illness and Emergencies subjects are taught in Year I Term II.

Course offered in Year II Term I are Complication of Antenatal, Intrapartum, Postnatal and Newborn, Gynaecology, Community Health Nursing I.

Course offered in Year II Term II are Community Health Nursing II, Mental Health Nursing, Introduction to Midwifery Research, Domiciliary Midwifery Care and Management of Home Delivery and Management of Rural Health Centre/ Sub Centre (DMS, 2011.pg.3).

Demand and Supply of Nurse Educators, Nursing Schools

Demand and supply are to be balanced in according with health care needs of population and health care facilities (Hospital and Community setting) both in public and private sectors under the Ministry of Health as well as other related Ministry.

Nursing Academic Education Programs

The University of Nursing (Yangon and Mandalay) and Nursing and Midwifery Training Schools (in all States and Regions) are provided with the following academic programs. These programs are of “ 4 years Bachelor of Nursing Science (B.N.Sc. Generic) , 2 years Bachelor of Nursing Science (B.N.Sc. Bridge Course). The (B.N.Sc. Bridge Course) is designed for nurses who are working in the service areas. The main aim is to upgrade the education of nurses for the provision of quality services to the population. Master of Nursing Science (M.N.Sc.) 2 years program also designed for faculty development. The University of Nursing offered post basic Diploma in Specialty Nursing including “Orthopedic Nursing, Pediatric Nursing, Mental Health Nursing, Critical Care Nursing, Eye, Ear Nose, Throat Nursing, and Dental Health Nursing”. The 3 years program of “ Diploma in Nursing, 2 years Program of Diploma in Midwifery and 1 year program Certificate for Lady Health Visitor” are conferred by Nursing and Midwifery training schools.

Table 1. Existing Nursing & Midwifery Educational Institutions

S.No	Categories of Institutions	Number
1	University of Nursing, Yangon	1
2	University of Nursing, Mandalay	1
3	Nursing Training Schools (All states & regions)	23
4	Midwifery Training Schools (All states & regions)	20
5	Lady Health Visitor (LHV) Training School	1
6	Field Training School	1
7	Domiciliary Training School	1
	Total number of Nursing and Midwifery educational Institutions	48

Institutional Development

The University of Nursing, Yangon was first Institute of Nursing in Myanmar and it was formerly called Nurses Training Centre (NTC), constructed with the support of the Government of Japan in 1986. NTC was upgraded to the Institute of Nursing in 1991 and offered 2-year B.N.Sc (Bridge) program for in service nurses who were working as the government employees. This is the first nursing degree program in Myanmar. In 1994, in order to accomplish the urgent needs and demands for the qualified and competent nurses who are able to provide better quality nursing care to the population served and the society, the ION, Yangon was honoured to produce the B.N.Sc (Generic) (four year course) graduates for individuals who passes Basic Education High School freshly and who were entitled for the University entrance. Thus, the curriculum for B.N.Sc (Generic) program was firstly developed and implemented in 1994. In 1996, the Institute conducted the Master of Nursing Science program through distance education with the University of Adelaide, Australia for three consecutive years and produced thirty M.N.Sc. graduates. In order to provide high quality nursing management and academic/service, postgraduate degree program conferred in 2001(UON,2001,pg.1). The Institute of Nursing was upgraded to University of Nursing in 2005. University of Nursing Mandalay was commenced in 1998 awarding B.N.Sc degree for Bridge and Generic program and follow the M.N.Sc program.

Teaching Department

University of Nursing is organized with many departments. Under the administration of Rector and Pro-rector Administrative aspect and academic aspects are implementing the University functions. Under the academic sector there are (15) departments including:- Department of Myanmar, Department of English, Department of Chemistry, Department of Physics, Department of Physiology, Department of Biochemistry, Department of Microbiology, Department of Pathology, Department of Pharmacology, Department of Fundamental Nursing, Department of Adult Health Nursing, Department of Maternal and Child Health Nursing, Department of Community Health Nursing , Department of Mental Health Nursing and Department of Dental Health Nursing. (UON, 2004).

Nurse and Midwife Manpower Production Situation

According to the table (1) , the students studying in 2012 academic year from all the Universities of Nursing and Nursing Midwifery Training Schools can observed. The (745) students are attending at University of Nursing , Yangon(720) students are attending at University of Nursing, Mandalay, (3791) nursing students at all nursing training schools in all over the country, (1459) Midwife students are also attending at Midwifery training school and (78) students at Lady Health Visitor Training School (MoH, 2012.pg.112).

Table 2. Number of Students attending in Universities and Training Schools (2012)

S.No	University/ Training Schools	Number of Students
1	University of Nursing, Yangon	745
2	University of Nursing, Mandalay	720
3	Nursing Training Schools	3791
4	Midwifery Training Schools	1459
5	Lady Health Visitor Training School	78

Table 3. Educational Categories of Nursing Midwifery Production

S.No	Degrees/ Certificate	Total no of Product
1	M.N.Sc	45
2	B.N.Sc	4103
3	Diploma in Nursing	25427
4	Certificate in Midwifery	32059
5	Lady Health Visitors	4058
6	Diploma in Specialty	287

According to the above table, (45) nurses with M.N.Sc,(4103) nurses with B.N.Sc, (25427) nurses with Diploma in Nursing, (32059) midwives with certificate in midwifery, (4058) Lady Health Visitors (LHV) and (287) nurses with Diploma in Specialized Nursing (DMS, 2012.pg.123).

Total number of teaching staff/educators in different position are instructor, tutor, Assistant Lecturer, Lecturer. Associate Professor. Professor and Pro- Rector. The total currently working educators are 90 person in each University of Nursing and over 400 person in Nursing and Midwifery Training.

Yearly intake for B.N.Sc (Generic) is about 150- 200 students for each University of Nursing, B.N.Sc (Bridge) is about 100- 120 students for each University of Nursing, M.N.Sc is 5-10 candidates, about 1000- 1200 students for Diploma in Nursing students in 23 Nursing Training Schools, about 1000 - 1200 students for Diploma in Midwifery students in 20 Midwifery Training Schools and 20 students for each diploma in specialty nursing courses.

Qualification of Nurse Educators (Current and Expected)

A nurse with (B.N.Sc) degree holder who has been at least two years experience in clinical settings can apply for nurse instructor for any training schools and Universities. A nurse holding diploma in nursing and midwifery can also apply nurse instructor after completion of B.N.Sc (Bridge Course). The clinical instructor with seven years of experience can apply nursing tutor post, then she /he can apply nursing principal. Assistant lecturer and principal posts are eligible for nurse tutor with M.N.Sc to apply.

Assistant lecturer with three years including one year experience of management in training school as principal can apply Lecturer post then later carrier of “Associated Professor and Professor posts are appointed by Ministry of Health as needed. To be able to suit with carrier development nurse educators must prepared with current advancement to meet with satisfactory level.

Non-Nursing Faculty Members must have post graduate in related subjects with at least 1 year experience or M.Sc in related subjects with at least three years teaching experience. (The Myanmar Nurse and Midwife Council Minimum requirements for the Accreditation of Nursing Education Program,2001.pg.3)

The expected qualification of nurse educators should have an education continuing upgrading up to the post graduate nursing degree programs including Doctor of Nursing (DNs) or Ph.D in order to provide the highest level of quality care to clients, regardless of setting. The provision of quality care also has accesses of research based practice consistent to theoretical constructs. (UoN, 2009.pg.1).

Research Development

Nursing education consist of teaching nursing research to all nursing degree programs. Each candidate is required to submit a research protocol to the Board of Studies (M.N.Sc) within 3-6 months from the commencement of the course. The research protocol must be proved by the board (UON, 2001). For the B.N.Sc course, the research can be conducted into group of five. All of graduates in nursing become well qualified with writing research protocol and conduct qualitative and quantitative nursing research. The research findings are published in Myanmar Nursing and Midwifery Journal regularly. The number of research published in 2006 are 2 , 2008 are 3, 2010 are 3, 2011 are 7 and 2012 are 7. The journals are distributed to all educational institutions and nursing midwifery services. At present, the nursing research is not widely engaged. It has been known that research development has important role in improving the quality of

care, quality of education, our problem concerning research development in nursing is attributed to lack of human resources and financial resources.

Challenges of AEC for Nursing Education

Although the UON conferred the postgraduate program, there is lack of nurses who have PhD degree in order to train master degree candidates. Myanmar nurses need more scholarship program to study master and PhD degree. We also faced with the lack of nursing textbooks and materials for student learning and their references. Moreover, another challenge is English language proficiency. Faculty development and faculty vacancies are critical challenges in nursing education.

Conclusion

Nursing is human service profession, dealing with varieties of ethnic groups, cultural and religious diversities. Nursing and midwifery provide service for both hospital institutions and community care setting. Nursing is now very complex and granted to the consumers to receive quality, comfort and safety care. Regarding nursing functions, there are both dependent and independent nursing functions.

In professional education, nurses study various interconnected subjects which can be applied to the practice setting. Nursing theory is the term given to the nursing knowledge discipline that is used to support nursing practice and derived from formal nursing research or non-nursing sources. A well-educated and competent nursing and midwifery workforce will improve the health care of the people of Myanmar at all levels of health care settings.

Annex (1) Nursing Education System

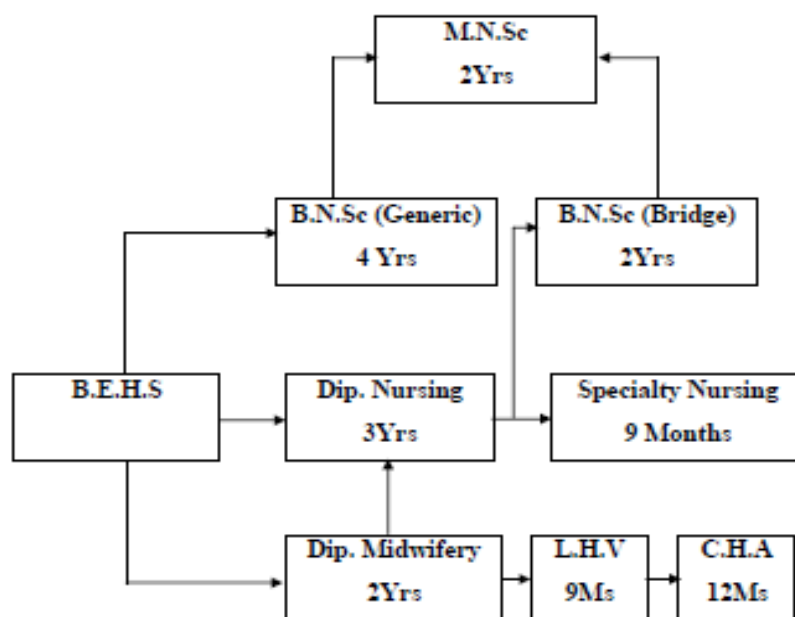

Annex (2) Organization Set-up of Department of Medical Sciences

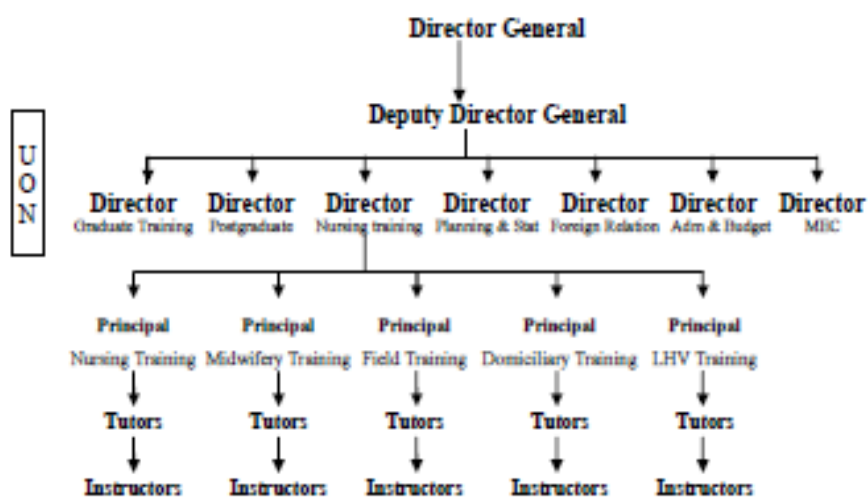

References

- University of Yangon. (2001). “Master of Nursing Science Curriculum”. Ministry of Health, Nay Pyi Taw, Myanmar.
- University of Yangon. (2004). “Bachelor of Nursing Science”. Ministry of Health, Nay Pyi Taw, Myanmar.
- Department of Medical Science. (2010). “Diploma in Nursing Curriculum”. Ministry of Health, Nay Pyi Taw, Myanmar.
- Department of Medical Science. (2011). “Diploma in Midwifery Curriculum”. Ministry of Health, Nay Pyi Taw, Myanmar.
- Myanmar Nurse and Midwife Council. (2001). “The Myanmar and Midwife Council Minimum Requirements for the Accreditation of Nursing Education Program. Strengthening of Nursing and Midwifery Regulation Project”. Yangon, Myanmar.
- Ministry of Health. (2012). “Health in Myanmar quoted in 2011”. Health Manpower Production, The Republic of the Union of Myanmar.
- University of Nursing. (2009). “Myanmar Nursing and Midwifery Journal”. Volume 4, No.1, WHO Collaborating Centre for Nursing and Midwifery Development. Yangon, Myanmar.

NURSING SERVICES IN MYANMAR

Phyu Phyu

Director Nursing, DOH,

President Myanmar Nurse and Midwife Council

The Republic of the Union of Myanmar

Abstract

Myanmar, as a developing country in ASEAN, is in the midst of political, Socio-economic, environmental, technological transition; having (60.38) million estimated population and 70% of it resides in the rural areas. Due to the rapid changes in demographic, epidemiological and economic trend, a long-term Health Development Plan has been drawn up in line with the National Health Policy, to meet the health needs of the population and future health challenges, within the available resources. The Ministry of Health is major responsible for providing health care services through strengthening public and private sectors. Mainly with the Primary Health Care approach, nurses and midwives are providing services from primary level to tertiary level. In terms of career ladder, the basic nursing education is diploma and up to master level; in nursing service sides, it starts with Midwife or RN up to the Director of Nursing. There is a need in nursing research and nursing workforce management to be balance with demand and supply including staff attrition. Some other important issues and challenges includes education development, quality services, accessibility, efficiency and equity, meeting health coverage with prevailing health problems

and challenges with AEC regarding Mutual Recognition Arrangement in nursing services among ASEAN MEMBER States.

Introduction

The republic of the Union of Myanmar, one of the ASEAN Member States, is located on the Bay of Bangal and Andaman Sea. It covers an area of (676,578) square kilometers.

Geography

Myanmar is administratively divided, into Nay Pyi Taw Union Territory and 14 States and Regions. It consists of 70 districts, 330 townships, 84 Sub-townships, 398 towns, 3063 Wards, 13,618 village tracts and 64,134 villages. Great diversity exists between the regions due to the rugged terrain in the hilly north, which makes communication extremely difficult.

Demography

The population in (2011-2012) is estimated at (60.38) million with the growth rate of 1.01 percent. The population density for the whole country is (89) per square kilometers. About 70% of the population resides in the rural areas, whereas the remaining are urban dwellers. In Myanmar, there are (8) major ethnic groups and (135) national races speaking over (100) languages and dialects. According to the age structure 2011-2012 is estimated as (0-14) years - 29.19%, (15-59) years - 62.01%, and (60) years and above - 8.80% respectively. [Ministry of Health (MOH). 2013. p.2-3]

Myanmar Health Vision

Myanmar is like other ASEAN developing countries, in the midst of political, Socio-economic, environmental, technological, demo-graphic and epidemiological transition. Considering the rapid changes in demographic, epidemiological and economic trend both nationally and globally, a long-term 30-year health development plan has been drawn up to meet the health needs of the population and future health challenges. (MOH.2012.p.22).

Health Care Needs and Nursing Needs

National Health Plan

To meet the health care needs of the population with the emerging trend of communicable and non-communicable diseases, The National Health Committee (NHC) sets its focus National Health Policy (NHP) and directs to achieve one of the social objectives to **“Uplift of health, fitness and educational standards of the entire nation”**. The National Health Plan Steering Committee and the NHP formulation sub- committee were formed with the responsible personnel from the intra and inter ministries and also from the Non-Governmental Organizations (NGOs). Health plans had been formulated and implemented systematically both at the national and regional level to see that available human, financial and material resources are most effectively and efficiently utilized to implement these programs.

Ministry of Health (MOH)

With the objective of **“Uplifting the health status of the entire nation,”** the MOH is taking the responsibility of health care services, covering activities for promoting health, preventing diseases, providing effective treatment and rehabilitation to raise the health status of the population. The Ministry of Health (MOH) remains as major provider of comprehensive health care.

Some ministries are also providing health care for their employees and their families. They include Ministries of Defense, Railways, Mines, Industry, Energy, Home and Transport. Ministry of Labor has set up three general hospitals, two in Yangon and the other in Mandalay to render services to those entitled under the social security scheme. Ministry of Industry is running a Myanmar Pharmaceutical Factory and producing medicines and therapeutic agent to meet the domestic needs.

Primary Health Care Approach

Maximum community participation in health activities is encouraged. Collaboration with related departments and social organizations has been promoted by the ministry. Considering health sector as a whole, the MOH is strengthening the

public-private partnership for health development. It also has a close collaboration with other sectors to take into account issues that are beyond the scope and capacity of the health sector.

Based on Primary Health Care approaches the MOH had formulated four yearly People's Health Plan from 1978 to 1990 followed by the National Health Plan from (1991-1992) to (2006-2011). These Plans have been formulated within the frame work of National Development Plans for the corresponding period.

National Health Plan (2011-2016) in the same vein is to be formulated in relation to the fifth five year National Development Plan. It is also developed within the objective frame of the short term third five year period of the Myanmar Health Vision 2030, a 30- year long term Health Development Plan. (MOH, 2012. p.24-27) (see Annex 1 : Health Development Plan)

With the ultimate aim of ensuring health and longevity for the citizens, the identified objectives have been adopted for developing program covering the fiscal year (2011-2012) to (2015-2016). Consequently, to achieve these objectives current National Health Plan (2011-2016) is developed around the 11 program areas, taken into account prevailing health problems in the country. It needs to be realized the health related goals articulated in the UN Millennium Declaration, significance of strengthening the health system and the growing importance of social, economic and environmental determinants of health. For each program area, objective and priority action are also identified. (MOH, 2012. p.24-25) (see Annex 2 : National Health Plan)

Nursing Care Services

For providing health care services to meet the health needs of the population with the emerging trend of diseases (e.g., malaria, tuberculosis, HIV/AIDS, heart diseases, diabetes, liver diseases etc.), there are systematic set-up at different levels; from central level General and Specialist Hospitals to State/Region, District, Township, Station level Hospitals, and Rural Health Centers and Sub-centres at grass roots level. nurses are mainly allocated at General/ Specialist Hospitals to Station Hospitals.

Primary level is based upon Sub-rural health centre and Rural Health Centre where Midwives, Lady Health Visitors and Health Assistants are assigned to provide primary health care services to the rural community; for those community who need further therapeutic care, are referred to Station Hospitals, Township Hospitals, and District Hospitals and to Specialist Hospitals respectively, for secondary and tertiary level of care services.

As nurses and midwives are major group in the health workforce and play key roles in providing comprehensive care, they need to be well-equipped with updated knowledge and skills at all level, so as to attain continuous professional development (CPD).

Health Care and Nursing System

The Department of Health (DOH)

The Department of Health (DOH) is mainly responsible for providing comprehensive health care services to the entire population in the country, where the Department of Medical Sciences (DMS) is for medical education including nursing and midwifery. DOH is headed by the Director General. Under the supervision of the Director General and Deputy Directors General, the following divisions are in operation; such as “Administration, Planning, Public Health, Medical Care, Disease Control, Epidemiology, Law and Legislation, National Health Laboratory, Occupational Health, Nursing, and Budget. (MOH, 2013, P.6)

Basic Health Care

Among these divisions, under the DOH, the Public Health Division is responsible for primary health care and basic health services down to the grass roots level, nutrition promotion and research, environmental sanitation, maternal and child health services, school health services and health education.

Medical Care

The Medical Care Division is responsible for setting hospitals’ specific goals and management of hospital services. Occupational Health Division takes the

responsibility for health promotion in work places, environmental monitoring of work places and biological monitoring of exposed workers.

Nursing Care

The Nursing Division at central level, DOH, is responsible for nursing care services at all level. The different categories of nurses in health system are providing health care at different levels according to the Organizational Hierarchy. From the top, the Director of Nursing at central administrative level/ departmental level, down to the Trained Nurses and midwives who are working at various community hospital settings and Rural Health Centres at the village level. There is another category called Township Health Nurse (THN) who is delivering community care services at township and peripheral level.

Nursing and midwifery personnel are key health manpower in providing comprehensive care in health delivery system in Myanmar. More than 70 % of rural population is served by community nursing personal including THNs, Lady Health Visitors and Midwives. Other categories of nurses are providing care at all hospital settings. Qualified nursing workforce should be utilized for better and quality health services for the public. Providing nursing services from central to grass roots community level is aiming to narrow the gap between urban and rural, and also quality and equity of services in the country.

Level of Nursing Staff Including Level of Education, Competency

Level of Education

Nurses are major workforce to provide comprehensive care services either public or private health care settings after completion of the basic nursing education program. Nursing midwifery personnel are produced by Department of Medical Sciences under the Ministry of Health. Basic level nurses are those who completed at least 3-year Diploma in Nursing, or completed 4-academic years B.N.Sc. (Generic) degree. Midwives are completed at least 18 months certificate or 2-year Diploma program. The Training Schools and University Institutions are managing for producing qualified and competent nursing workforces.

Nurses workforce with diploma nursing education has been upgrading with 2 years academic education of B.N.Sc (Bridging program) and provide nursing services in their respective fields or areas. Every year, 100-150 diploma nurses have been upgraded and utilized in the health care sector. Nurses have more opportunities to extend their educational carrier up to Master of Nursing Science (M.N.Sc.) degree level. The Ph.D nursing and Doctor of Nursing programs are expected to be upgraded in near future.

According to the nursing educational sector, there are also different categories in hierarchy ladder, naming as Clinical Instructor, Tutor, Assistant Lecturer, Lecturer, Associated Professor, Professor and Deputy Rector. These categories are nurse educators who are managing and teaching at various Nursing, Midwifery Training Schools and University of Nursing. (Ref. Annex 4: Career Ladder in Nursing Education)

Another post-basic level is production of specialty nursing such as “Psychiatric Nursing, EENT Nursing, Orthopedic Nursing, Pediatric Nursing, and Critical Care Nursing”. These graduates are being utilized and serving with specialized nursing skills in all respective health care settings to the specific clients. This is very beneficial utilization and meets for the needs of total nursing care. The other delivery of systematic and appropriate nursing care practice is utilization of nurses in the respective areas after provision relevant continuing nursing education.

Level of Nursing Staff at Public Service

In promotion, level of nursing staff at different positions are regarded the upgraded level of education, years of working experiences and some other credentials and criteria in regard to departmental regulations. Under the public health sector, the position level started at Trained Nurse and can be promoted according to the Career Ladder up to Director of Nursing. (Ref. Annex 3: Career Ladder in Nursing Service)

Demand and Supply of Nursing Staff

Production

The Department of Medical Sciences is responsible for carrying out the training and production of all categories of health personnel with the objective to appropriate mix of competent human resources for delivering the quality health care services. It is crucial to produce competent human resources for health to keep competency standard/s with quality assurance and consumer satisfaction. The DMS has seven divisions, which includes Nursing Training Division. The appropriate mix of different categories of health professional is being produced from the 14 medical and allied universities and 46 nursing and midwifery training schools under DMS. In yearly production of nurses are: 1000-1200 in diploma nursing, 120-130 in B.N.Sc.(Generic), 100-150 in B.N.Sc. Bridge program and 1000-1200 in midwifery course. Health man power production as of February 2013, is B.N.Sc. 4436, Diploma Nurse 26548, Midwifery 32985 and LHV 4136. (MOH. 2013. P.117- 120)

Utilization

According to Health Statistics 2013, 28254 nurses, 3397 Lady Health Visitors, and 20617 midwives are being utilized in the public health care sectors. Supply and demand of nurse manpower need to be balanced with interdepartmental collaborative planning. Production of all categories of health personnel is considered to attain appropriate mix of competent human resources for quality services. In 2012, 2563 nurses and 935 midwives are newly appointed to hospitals and community settings according to the vacancies and new sanctions, as needed under the DOH. Vacancies are filled from time to time usually in every quarter of the year as necessary.

Moreover, there are many private hospitals and health care facilities, mostly in the big cities to township level and many nurses and midwives are working in the private health care settings. There should be a balance between production and demand or utilization as expected. However, there are more and more increasing of private health care facilities and more nurses and midwives are

in demand. The attrition rate is also increased in public sectors. (DOH, 2013) (MOH, 2013. P.121-125)

Concerning to the health man power workforce planning, in the public sector, the main responsibility is taken by Division of Planning, 'Health Economic Unit', under the DOH. It is mainly responsible for new set-up of different hospitals, upgraded hospitals, with the organization set-up and sanctions posts. Setting up new or up-graded hospitals (16 bedded to 1000 bedded) are to be planned and implemented according to the community needs and National Health Development Plan.

Licensing

The Nurse and Midwife Council Law

With regard to nursing/midwifery system in Myanmar, the three components are very essential. These are "The Departmental component, The Myanmar Nurse and Midwife association (MNMA) component and The Myanmar Nurse and Midwife Council component". The Myanmar Nurse and Midwife Council (MNMC) is regulatory authority body and being responsible for regulating nursing services and education through applying Nurse and Midwife Law. In Myanmar, nursing and midwifery was regulated with **The Midwife and Nurse Act** since on 1st November, 1992, in Burma Act X, 1922. According to that Act, nurses and midwives were registered, (9386 in total number).

This Act had been amended and enacted with "**The Myanmar Nurse and Midwife Law**", on 17th October, 1990, (by The State Law and order Restoration Council, Law No. 19/90). In 2002, that Law was amended again in some of the area:- Law No.22; regarding nursing and midwifery education, i.e., the Department of Medical Sciences has to be responsible for entrance, training, education, examination and conferring certificates, diploma and degree (by The State Peace and Development Council, 14/2/2002).

Licensing: The Myanmar Nurse and Midwife Council

Up to 2002, The MNMC conducted Nurses and Midwives' State Examination, conferred certificates and Diploma, and kept in the registration before they are in practice. Since 1990, the council regulated the above functions as well as issuing the license to practice. There are three types of license; Midwife, Nurse, Nurse-midwife License issued by MNMC. All nurses and midwives must have active license through renewal of license in every 2 years. The one-year (temporary/limited) license is issued for registered new graduate nurses and midwives during waiting for government services as necessary. License for nurses and midwives are to be issued according to the procedure guidelines after satisfactory completion of education programs of prescribed schools (under DMS) by the Council. Recently, in 2012, the existing MNMC Law has been revised as required and submitted the revised MNMC Law (2nd Draft) to MOH for further approval. In future, Myanmar Nurse and Midwife Council will develop criteria for accreditation of nursing education and practice. (MNMC, 2013)

Nursing Staff Development/Training Course

Nursing Education and Staff Development

Staff development program is critically important for nursing and midwifery personnel to strengthen their knowledge capacity and upgrade their capabilities in line with changing needs of society and clients' needs. Human resources for health are the most important for successful implementation of National Health Vision and Mission. At present, Nursing Division, Department of Health and Department of Medical Sciences initiate and encourage continuing nursing education activities within the respective settings. In future, this continuing nursing education activities and continuing professional development (CPD) will be encouraged and recognized as requirement for licensing and relicensing process. There are regular yearly intake of diploma nurses to B.N.Sc. (Bridge-courses) and some other post-basic special program in University of Nursing, Yangon and Mandalay. Further, there are Master of Nursing Science programs undertaking

yearly in the above Nursing Universities. For producing skillful midwives, 2-year diploma midwifery curriculum had been developed and curriculum orientation workshops for trainers were done during 2012. The new midwifery curriculum has been started since November 2012. To improve the capacity building of all faculty members of nursing and midwifery training schools, the TOT workshops on implementation of New Midwifery Curriculum and Competency-Based Trainings on Pregnancy, Childbirth, Postpartum and Newborn Care (PCPNC) were also conducted during 2012. (MOH. 2013. P.118)

In Service Staff Development Training/Program

Nursing Division have some nursing projects as WHO Collaborative programs with funding support for the nurses to equipped with capacity building; the number of participants is depend on the allocated fund available. The **“Leadership For Change”** (LFC) 2-year program is being implemented as ‘learning by doing’ method. In each program, about 30-32 senior nursing personnel are participated as team-projects. The LFC program is currently implementing up to “Phase 6”. These programs are being technically supported by the International Council of Nurses. Similarly, the **“infection control practice”** program, supported by WHO, is another important area for the nurses to be updated knowledge with WHO Guidelines in terms of safety practice.

The University of Nursing (UON), Yangon, is being the WHO Collaborating Centre for Nursing and Midwifery,” is preparing “Strategic Direction of National Nursing and Midwifery Development Plan” for 2013-2017, with five key result areas including nursing service and education to be strengthened. (UON, 2013)

Apart from that, however, not on regular-basic, there are some other program areas, to upgrade in-service nurses and midwives e.g., giving short courses, refresher trainings, workshops are available in some kind, at the central, regional, township level conducted by the concerning health department respectively as necessary, especially aiming for implementing health service program areas.

Research Development

Nursing education provide nurses to become research culture. Bachelor of nursing degree program is needed to submit nursing research protocol and conduct nursing research as course requirement for conferring degree. The B.N.Sc. students must conduct quantitative research study. However, in Master of Nursing Science program, students have both quantitative and qualitative exposure to conduct nursing research.

Evidence based nursing and nursing research findings have been encouraged to integrate in the nursing and midwifery practices. Myanmar Nursing and Midwifery Journal are published regularly, with research papers/articles and distributed to all departments and nursing managers as far as possible in the county. The Journal is issued from University of Nursing, Yangon, WHO Collaborative Center for Nursing and Midwifery Development.

With respect to the research utilization in nursing practice, Myanmar nurses will have benefits to provide scientific and evidence based care to the population. However, in the service side, the clinical staff have insufficient research knowledge and skill as well as not much time to do clinical research with daily burden of workload during 24-hour duty shifts in rotation. In addition, wide dissemination of research findings and research utilization (research consumer) in the nursing practice is still necessary in terms of research development and research culture.

Challenges of AEC for Nursing Services in Myanmar

Involving in ASEAN MRA

Nursing and midwifery personnel are essential manpower work force. With the workforce planning and proper skill mix, Myanmar is managing, producing and utilizing nurses and midwives to employ nurses and midwives in private and public sectors to meet demand and supply. Myanmar, as a member state of ASEAN, have been involving for achievement to enter ASEAN Economic

Community (AEC) in 2015, also with health sector integration particularly in the MRA for health services.

MRA: Country Road-map

Myanmar Nurse and Midwife Council (MNMC) is preparing Country Road-map Plan for the implementation of ASEAN MRA. The Country Road-map Plan Template has to be submitted to ASEAN secretariat office. This would be the first attempt to develop a common set of professional standards/ competencies in health care services and health workforce for mutual recognition within ASEAN region, as Professor U Maung Maung views that “The MRA on nursing services is regarded as the first step toward more robust MRA’s in the region.” (Professor U Maung Maung, 2012, p. 12)

The Professional Regulatory Authority (PRA) of the host country can still retain the right to recognize foreign nursing qualifications. The PRA have to set the core competency standard for their own country in line with ASEAN agreement in ASEAN Joint Coordination Committee in Nursing (AJCCN).

There are challenges to reform nursing midwifery regulation across the country. Foreign registered nurses are required to work with local nurses and will still need to apply for temporary license (limited license) to the PRA of host country, according to the newly revised MNMC Law which is in preparatory stage for approval by the government.

Further, there would be many issues and challenges of AEC for nursing services in Myanmar which may include : - different curriculum standards in nursing education programs; Accreditation of schools/ institutions, different level of staff and scope of practices; inability to update with advanced information technology and advanced practices; and a wide range of diversity such as, many languages barrier, different national races and cultural sensitive, etc.

Conclusion

Entering the 21st century, Myanmar is implementing numerous programs for all round national development and promoting the quality of life of the people.

In the health sector, the MOH is systematically developing health plans, aiming toward “Health for All Goal.” According to Myanmar health Vision 2030, the 30-year long term Health Plan is set-up with the ultimate aim of ensuring health and longevity for the citizen. The current NHP (2011-2016) is developed around the eleven program areas to be taken into account on prevailing health problems in the country. It is necessary to realize the health related Millennium Development Goal’s (MDGs), significance of strengthening the health systems and the growing importance of social, economic and environmental determinants of health.

The health sector has to address the health problems and health issues of the population as nation-wide, with the guidelines of National Health Policy and Health Development Plan. The challenge of the 21st century issues on accessibility, equity, effectiveness, efficiency and ensuring quality of health care will be a priority. When providing health care, some other issues and challenges would be underlined within the country and that should be considered as “limitations”, for example, having around 60.38 million population with seventy percent (70%) resides in the rural areas, and out-reach areas for equity access, meeting health coverage, different health needs with double burden diseases of communicable and non-communicable, socio-cultural issues with 135 national races speaking over 100 languages within different ethnic groups and more importantly, managing scarce resources with quality out-come of services.

Regarding nursing services, the standards of care and professional competency should also be updated by continuous professional development. Through competent, safety practice and greater preparation of nursing education, nurses would be, in future, taking independent roles and collaboratively working with advanced nursing practices and with better professional image, as they are the major essential group of health workforce.

Health Development Plan

(Annex-1)

With the objective of uplifting the health status of the entire nation, the Ministry of Health is systematically developing Health Plans, aiming toward Health for All Goal. From 1978 onwards four yearly People's Health Plans have been drawn up and implemented. Since 1991, short term National Health Plans Have been developed and implemented.

Main components of the plan

1. Health Policy and Law
2. Health Promotion
3. Health Service Provision
4. Development of Human Resources for Health
5. Promotion of Traditional Medicine
6. Development of Health Research
7. Role of Co-operative, Joint Ventures, Private Sector and NGOs
8. Partnership for Health System Development
9. International Co-operation

National Health plan (2011-2016)

(Annex-2)

Based on primary Health Care approaches the ministry of Health had formulated four yearly People's Health Plans From 1978 to 1990 followed by the National Health Plans from 1991-1992 to 2006-2011. These plans have been formulated within the frame work of National Development Plans for the corresponding period.

National Health Plan (2011-2016) in the same vein is to be formulated in relation to the fifth five year National Development Plan. It is also developed within the objective frame of the short term third five year period of the Myanmar Health Vision 2030, a 30 year long term health development plan.

With the ultimate aim of ensuring health and longevity for the citizens the following objectives have been adopted for developing programs for the health sector in ensuing five year covering the fiscal year 2011- 2012 to 2015-2016.

1. To ensure quality health services are accessible equitably to all citizens
2. To enable the people to be aware and follow behaviors conducive to health
3. To prevent and alleviate public health problem through measures encompassing preparedness and control activities
4. To provide quality health care for citizens by improving quality of curative services as a priority measure and strengthening measures for prevention and rehabilitation
5. To provide valid and complete health information to end users using modern information and communication technologies
6. To plan and train human resources for health as required according to types of health care services, in such a way to ensure balance and harmony between production and utilization
7. To intensify measures for development of Traditional Medicine
8. To make quality basic/essential medicines, vaccines and traditional medicine available adequately
9. To take supervisory and control measures to ensure public can consume and use food, water and drink, medicines, cosmetics and household materials safely
10. To promote in balance and harmoniously, basic research, applied research and health policy and health systems research and to ensure utilization as a priority measure
11. To continuously review, assess and provide advice with a view to see existing health laws are practical, to making them relevant to changing situations and to developing new laws are required
12. In addition to providing health services, to promote collaboration with local and international partners including health related organizations and private

sector in accordance with policy, law and rules existing in the country for raising the health status of the people

13. Consequently, to achieve these objectives current National Health Plan (2011-2016) is developed around the following 11 program areas, taken into account prevailing health problems in the country, the need to realized the health related goals articulated in the UN Millennium Declaration, signification of strengthening the health system and the growing importance of social, economic and environmental determinants of health. For each program area, objective and priority action to be undertaken have also been identified.

Program Areas

- a) Controlling Communicable Diseases
- b) Preventing, Controlling and Care of Non-Communicable Diseases and Conditions
- c) Improving Health for Mother, Neonates, Children, Adolescent and Elderly as a Life Cycle Approach
- d) Improving Hospital Care
- e) Development of Traditional Medicine
- f) Development of Human Resources for Health
- g) Promoting Health Research
- h) Determinants of Health
- i) Nutrition Promotion
- j) Strengthening Health System
- k) Expanding Health Care Coverage in Rural, Peri-urban and Border Areas

(Annex 3)

Career Ladder in Nursing Service (DOH)

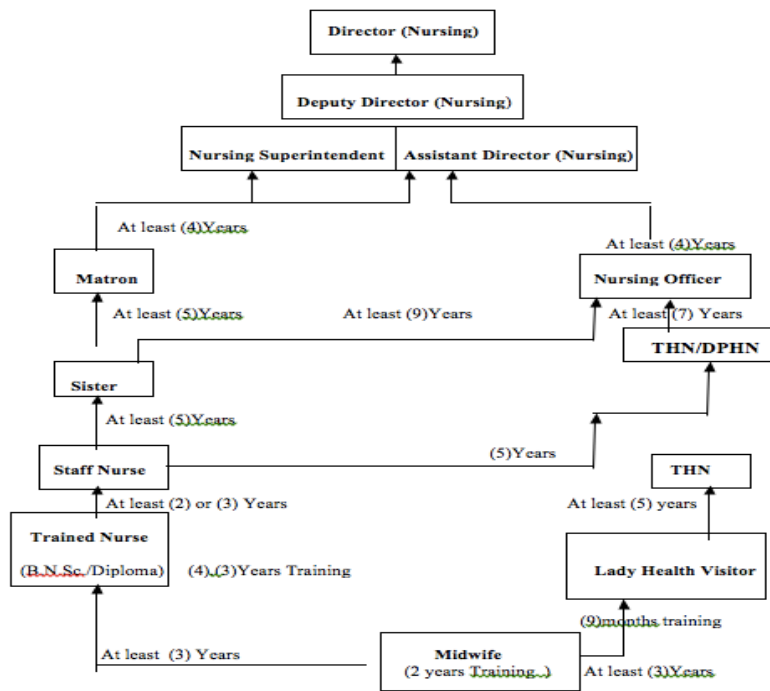

Career Ladder in Nursing Education (DMS)

(Annex-4)

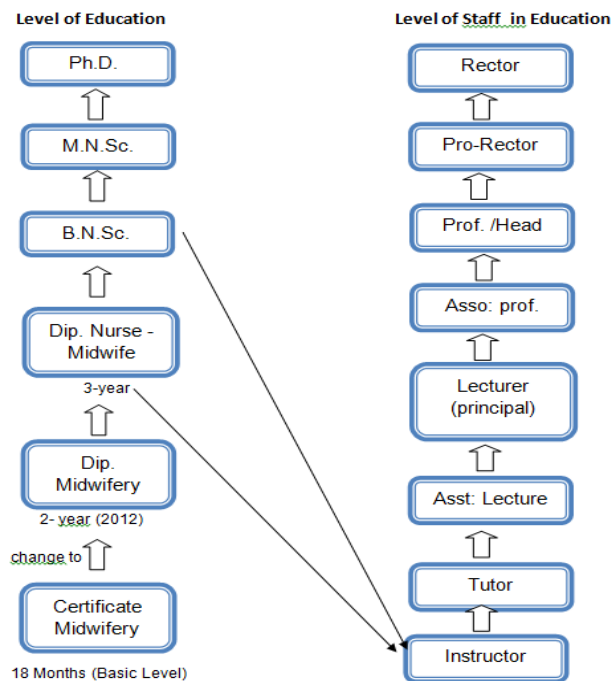

References

- Ministry of Health. (2000). *Health in Myanmar 2000*. Ministry of Health. Nay Pyi Taw. Myanmar. (p.5-8).
- Ministry of Health. (2012). *Health in Myanmar 2012*. Ministry of Health. Nay Pyi Taw. Myanmar. (p.22-124).
- Ministry of Health. (2013). *Health in Myanmar 2013*. Ministry of Health. Nay Pyi Taw. Myanmar. (p.2-138).
- Myanmar Nurse and Midwife Council.(2001). *Minimum Requirements for the Accreditation of Nursing Education Program*. Strengthening of Nursing and Midwifery Regulation Project. 2001. Myanmar Nurse and Midwife Council, Yangon, Myanmar.
- Professor. U Maung Maung (2012). *Quality Nursing and Midwifery practice Recognition of regulatory mechanism of nursing midwifery education and services*, Myanmar Nursing and Midwifery Journal, University of Nursing, Yangon, 2012, vol.7, No.2, December 20 (p.1-13)

NURSING EDUCATION IN PHILIPPINES

*Associate Professor Bethel Buena P. Villarta, Dr.P.H., RN
College of Nursing, University of the Philippines Manila*

Nursing Educational System and Curricula

The practice of the Nursing profession in the Philippines is guided by Republic Act (RA) 9173 entitled An Act Providing for a More Responsive Nursing Profession. It is also known as the Philippine Nursing Act of 2002. Article V of this law specify provisions pertinent to Nursing Education. On the other hand, implementing guidelines and regulations pertinent to nursing education are issued by the Commission on Higher Education (CHED), an agency attached to the Office of the President.

I would like to state on the outset, however, that the University of the Philippines, having been designated as the National University under RA 9500, is not under the supervision of the CHED since it has its own Charter. Thus, all units of the University of the Philippines, including the College of Nursing, set their own norms and guidelines based on prevailing standards of excellence of their respective professions.

Agencies and Organizations Involved in Nursing Education in the Philippines

Nursing Education in the Philippines is guided and supervised by Commission on Higher Education (CHED) which is the government body tasked to oversee public and private higher education institutions. CHED Memorandum Order No. 14, Series of 2009, otherwise known as CMO 14 was issued for the

“purpose of rationalizing Nursing Education in the country in order to provide relevant and quality health services locally and internationally”. (CHED, 2009)

A memorandum order (MO) is the CHED’s way of issuing implementing guidelines and regulations. The CHED relies on the Technical Committee on Nursing Education (TCNE) to help it formulate implementing rules and guidelines as well as monitor compliance to these rules and guidelines by nursing colleges. The TCNE is composed of leaders in nursing education in the country representing both government and private nursing colleges.

Another government agency involved in Nursing Practice and Education is the Professional Regulations Commission (PRC) which is also an attached agency of the Office of the President. Issues and concerns specific to the Nursing profession are referred to the Board of Nursing (BON). The organization, responsibilities and qualifications of the members of the BON is defined in RA 9173. The main task of the BON is the conduct of the licensure examination for nurses as well as the issuance of certificate/license to practice to qualified professional nurses. In addition, the BON is also tasked to coordinate with the accredited professional organization and appropriate government or private agencies in order to conduct studies on health human resources production, utilization and development.

Participation of nursing leaders in regulation and coordination of nursing education is done through consultation with the national organizations of nurse educators, the Association of Deans of Philippine Colleges of Nursing (ADPCN) and the national professional organization of nurses, the Philippine Nurses Association (PNA). Specialty groups of professional nurses such as the Association of Nurse Supervisors and Administrators of the Philippines (ANSAP), Gerontology Nurses Association of the Philippines (GNAP), Operating Room Nurses Association of the Philippines (ORNAP), and others are also consulted. The University of the Philippines Manila College of Nursing (UPM – CN) as the World Health Organization Collaborating Center (WHOCC) for Nursing Leadership and Development is also an active partner of the BON and the CHED.

This collaboration between and among the different agencies and organizations involved in nursing education can be illustrated as follows:

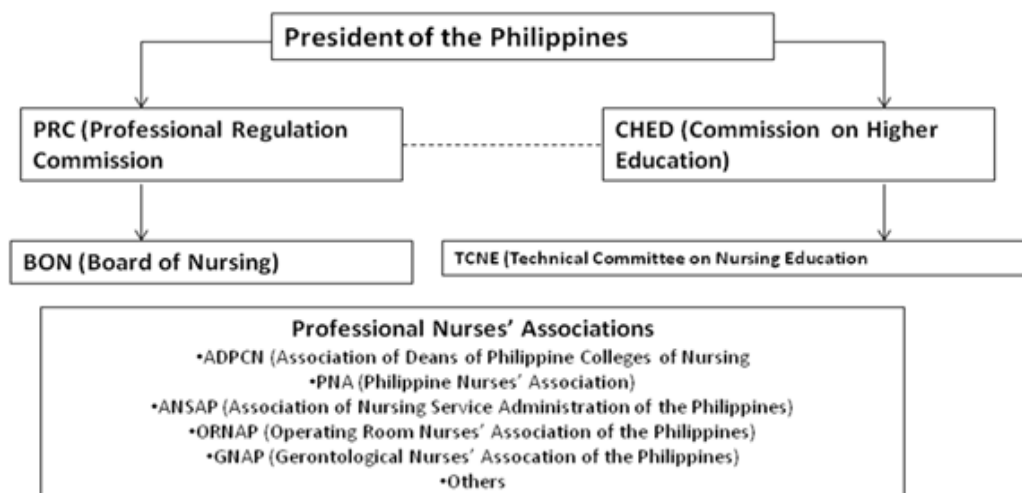

Another group of organizations that are involved in nursing education are the accrediting organizations which visit applicant colleges of nursing and rate their compliance with accreditation criteria in the areas of Goals and Objectives, Faculty, Curriculum and Instruction, Library and Computer Laboratory, Laboratories and Clinical Training, Physical Plant, Student Services and Administration.

Nursing Programs Offered

Section 25 of RA 9173 describes the Nursing Education Program as one that “shall provide sound general and professional foundation for the practice of nursing. The learning experiences shall adhere strictly to specific requirements embodied in the prescribed curriculum as promulgated by the Commission on Higher Education's policies and standards of nursing education”.

Three nursing programs are offered in Philippine higher education institutions: Bachelor of Science in Nursing, Master of Arts in Nursing (MA Nursing) and the Doctor of Philosophy in Nursing (PhD Nursing).

Bachelor of Nursing Curricula

The Philippines offer the Bachelor of Science in Nursing program. It is a four – year program, which is open to graduates of high school or secondary education. Applicants should also pass the admission requirements of the respective universities/colleges, which may include passing a college admission test and interview. The program consists of general education and professional courses. It aims to “produce a fully functioning nurse” who is able to perform competencies under each of the following Key Areas of Responsibility: Safe and Quality Nursing Care, Management of Resources and Environment, Health Education, Legal Responsibility, Ethic – Moral Responsibility, Research, Records Management, Communication, and Collaboration and Teamwork. (CHED, 2009.)

Professional courses start in the first year and threads through the development of identified competencies up to the fourth year. In addition to professional courses, students take courses in basic sciences which are pre - requisites for the professional courses. These include units in chemistry, pharmacology, microbiology, parasitology, anatomy and physiology, psychology, sociology and anthropology. They are also required to take up general education courses such as communication, language (usually, English), history and humanities. Following are the courses, which a student of Bachelor of Science in Nursing is supposed to take and the corresponding units. (CHED, 2009)

Table 1. Courses in Bachelor of Science in Nursing

<u>Courses</u>	<u>Units</u>
A. General Education	87
Language and Humanities	21
English 1& 2 (Communication Skills)	6
English 3 (Speech and Communication)	3
Filipino 1 & 2	6
Philosophy of Man	3
Logic and Critical Thinking	3
Mathematics, Natural Sciences & Information Technology	22
Mathematics (College Algebra)	3
Biostatistics	3
General Chemistry 3/2	5

Biochemistry 3/2	5
Physics 2/1	3
Informatics 2/1	3
Health Sciences	9
Anatomy and Physiology 3/2	5
Microbiology and Parasitology	4
Social Sciences	15
General Psychology	3
Sociology/Anthropology	3
Humanities (World Civilization and Literature	3
Economics with Taxation and Land Reform	3
Bioethics	3
Mandated Subjects	20
Life, Works and Writings of Rizal	3
Philippine History, Government and Constitution	3
Physical Education (PE) 1 to 4(2 units each)	8
B. Professional Courses	115
Theoretical Foundations in Nursing	3
Health Assessment (2/1)	3
Community Health Nursing (3/2)	5
Nutrition and Diet Therapy (3/1)	4
Health Education	3
Pharmacology	3
Nursing Research I (2/1)	3
Nursing Research II	2
Competency Appraisal I	3
Competency Appraisal II	3
Elective I	2
Elective II	2
NCM 100 – Fundamentals of Nursing Practice (3/2)	5
NCM 101 – Care of Mother, Child and family (4/4)	8
NCM 102 – Care of Mother, Child, Family and Population Group At Risk or With Problem (5/6)	11
NCM 103 – Care of Clients with Problems in Oxygenation, Fluid And Electrolyte Balance, Metabolism and Endocrine (8/6)	14
NCM 104 – Care of Clients with Problems in Inflammatory and Immunologic Response, Perception and Coordination (5/4)	9
NCM 105 – Care of clients with Maladaptive Patterns of Behavior (4/2)	6
NCM 106 – Care of Clients with Problems in Cellular Aberrations, Acute Biologic Crisis including Emergency and Disaster Nursing (6/5)	11
NCM 107 – Nursing Leadership and Management (4/3)	7
Intensive Nursing Practicum (8)	8
Grand Total Number of Units	202

Competency Based BSN Program of UPM – CN

The University of the Philippines Manila College of Nursing offers a Competency Based Bachelor of Science InNursing Program. It is designed to prepare nurses for their roles as practitioner, manager/leader and researcher in a work setting scenario which was derived from an analysis of the demographic profile, health situation of the country as well as socio – economic and cultural factors affecting the health of the people. (Please see the competency basedframework on page 8 of this manuscript, where it is presented in connection with the NNCCS wherein it was used as a model)

As a practitioner, the student nurse in UPM – CN is trained to provide nursing care to individuals, families, population groups and communities as they progress from the first to the fourth year of their studies, taking into consideration the three levels of prevention. Further, they are trained to consciously practice the nursing process as they proceed to identify and implement the different goals of care while being guided by concepts of health and illness. This integration framework in curricular design followed by UPM – CN can be illustrated as follows:

University of the Philippines Manila, College of Nursing. Competency Based Nursing
 University of University of the Philippines Manila, College of Nursing. Competency
 Based Nursing Curriculum: A Model. 2006

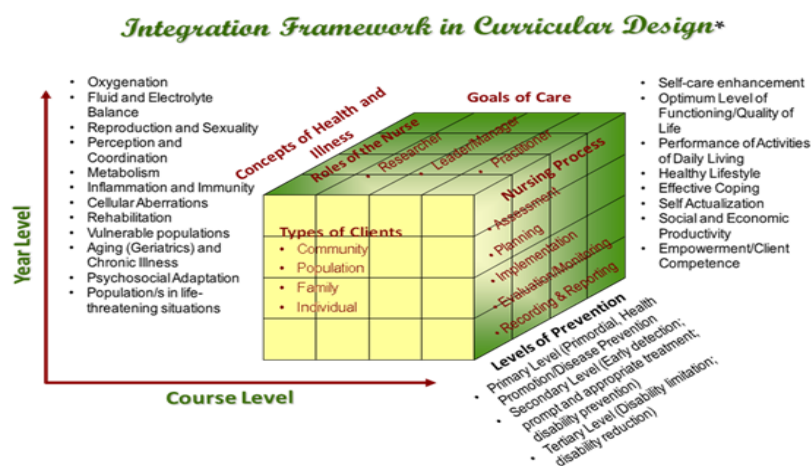

Figure 1. Model of Intregation Framework in Curriculum Design

Ladderized BSN Program at School of Health Sciences of UP Manila

Another way of becoming a nurse in the Philippines is via the ladderized program, an innovation of the University of the Philippines Manila. This program is non-competitive, which means students entering this program do not have to pass the University of the Philippines College Admission Test (UPCAT). However, they have to be sponsored by their respective Local Governments (Barangay/Village, Municipal or Provincial) or by a non-government or volunteer organization in order to gain entrance to the course. They (students) also promise/sign a contract that they are going to serve their respective sponsoring organization for at least two years after finishing the course.

After finishing the first two years of education, successful students graduate with a certificate in midwifery and are qualified to take the midwifery licensure examination. If they pass this examination, they go back to their sponsoring organization and serve a minimum of two years as midwife. If interested and are qualified (i.e. have high grades), they maybe allowed to proceed for two more years of education after which they graduate with a BS Nursing degree.

National Nursing Core Competency Standards

In 2010, the Board of Nursing initiated the development of the 2012 National Nursing Core Competency Standards. (Abaquin, 2013) Issuance of these nursing core competency standards is seen as timely in view of the K – 12 Program of the Department of Education (DepED) as well as the ASEAN 2015. The K to 12 program would standardize the Philippine educational system to include kindergarten and 12 years of basic education (six years of primary education, four years of Junior High School, and two years of Senior High School). The program is designed to “provide sufficient time for mastery of concepts and skills, develop lifelong learners, and prepare graduates for tertiary education, middle-level skills development, employment, and entrepreneurship”

(www.gov.ph/K-12, 2013). On the other hand, ASEAN 2015 envisioned integration of the ASEAN nations into one economy.

The 2012 National Nursing Core Competency Standards were developed using the Competency Based Framework in Curriculum Design as well as a Creation Paradigm (Abaquin, 2013). Use of the creation paradigm means that the designers went through the steps of Competency Based Curriculum Design without referring to the current BSN curriculum. The process of Competency Based Curriculum Design starts with work setting scenario analysis which provides the basis for identifying the professional roles of the beginning professional nurse. The process proceeds to specify the professional responsibilities and tasks which would then provide the basis for identifying the skills, knowledge and attitudes, collectively known as the competencies, of the beginning professional nurse. The beginning competencies of the professional nurse provides the basis for identifying competencies of the student nurse at the start (entry competencies), during or while undergoing the BSN curriculum (intermediate competencies) and by the time he/she graduates from the BSN program (terminal competencies) (Maglaya in UPCN, 2006). The above process can be better appreciated in the following diagram.

At the core of 2012 National Nursing Core Competency Standards is the care of four identified clients of the nurse: individual, family, population groups and community. The identified and validated roles of the beginning nurse are on client care, management and leadership and research. A total of fourteen (14) responsibilities and eighty six (86) competencies have been identified. (Abaquin, 2013) Following is the conceptual framework of the (Revised) National Nursing Core Competency Standards of Philippine Nursing.



Conceptual Framework of the Revised Nursing Core Competency Standards of Philippine Nursing

(Abaquin, Carmencita M. 2012 National Nursing Core Competency Standards.
April 25, 2013).

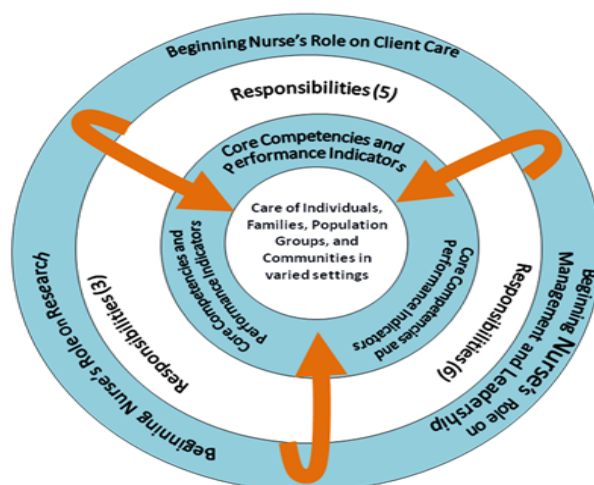

From the framework, it will be noted that the revised National Nursing Core Competency Standards identified the beginning nurse's roles on Client Care, Management and Leadership and Research. It consists of a total of fourteen (14) responsibilities and eighty six (86) competencies. The breakdown of these competencies are summarized in the following table.

Summary of Competencies per Responsibilities and Roles

Beginning Nurse's Role On Client Care		Beginning Nurse's Role On Management And Leadership		Beginning Nurse's Role On Research		TOTAL
Responsibility	Competency	Responsibility	Competency	Responsibility	Competency	
R1	5	R1	4	R1	4	
R2	31	R2	4	R2	4	
R3	3	R3	2	R3	4	
R4	2	R4	7			
R5	4	R5	8			
		R6	4			
TOTAL L = 5	45	TOTAL L = 6	29	TOTAL L = 3	12	TOTAL R 14 C 86

Abaquin, Carmencita M. 2012 National Nursing Core Competency Standards. April 25, 2013.

Master of Arts (Nursing): Residential and Distance Mode

The primary goal of the master's program in Nursing is to prepare qualified nurses for clinical specialization and leadership in any of the following major fields: Adult Health Nursing (AHN), Community Health Nursing (CHN), Maternal and Child Nursing (MCN), Mental Health and Psychiatric Nursing (MHPN), Nursing Administration (Nsg. Admin) and School Health Nursing (SHN).

The MA (Nursing) degree requires completion of thirty six (36) units, thirty (30) units of which are credited to academic courses and six (6) units for thesis. Criteria for admission include: a BSN degree, at least one (1) year work experience as a nurse in a hospital, community or public/private health agency, and have scholastic ability and potential for graduate study. In addition, foreign students need to show proof to practice nursing in the country of origin, TOEFL score of at least 500, passport and certification on financial capability or affidavit of support. (UPM-CN, 2012)

Students under the residential MA (Nursing) attend classes at the UPM – CN building on Pedro Gil St., Ermita, Manila at least once a week for those doing part time studies or twice a week for those doing full time studies.

Students under the distance mode MA (Nursing) log – on to an internet portal, participate in virtual classroom discussions, teleconferencing and complete other requirements (exams & term papers) via the internet. For clinical subjects, they report for practicum at the Philippine General Hospital under the supervision of their designated preceptor by the end of the semester.

Doctor of Philosophy in Nursing

The PhD Nursing program is designed to strengthen and deepen the intellectual and scholastic capability of graduate nurses in order to enhance the theory and science – based practice of the profession.

Applicants for the PhD (Nursing) should be graduates of BSN, have an Main Nursing or other health – related fields, show evidence of ability to pursue

advanced studies in the area covered by the student's chosen program and comply with general requirements for the PhD program of the UP System, which are high quality and integrity of intellect and English proficiency. (UPCN Catalogue of Information, 2010)

Demand and Supply of Nurse Educators

The demand for nurse educators goes with the number of nursing schools being opened in the country. The number of nursing schools in the Philippines slowly went up from 190 in the late 1990s to a high of 463 in 2008. This rise in nursing colleges is fueled by international demand for Filipino nurses, offering them high paying jobs especially in Saudi Arabia, United States and United Kingdom.(Cirujales and Kuan, 2012)

Only those who meet desired qualifications of overseas employers can get jobs. It is thus, safe to assume that each nurse who go abroad is a drain not only in physical resources but more so, in intellectual resources. A review of the qualifications of the faculty of colleges of nursing would show that they, too, suffered from the exodus of their faculty members. This is reflected in a study of the profile of colleges of nursing faculty. While the Philippine Nursing Law of 2002 requires that all nursing faculty should have a Master of Arts degree, Divinagracia (2006) cites that out of 2,392 faculty surveyed in 2003, only 1,157 [58%] are BSN graduates with MA units; 539 [22.53%] have Master of Arts in Nursing (MAN) and 198 [8.28%] have MAs in other fields. Thus, while the colleges of nursing were adequately manned by nurses, data showed that not all of them met the qualifications required for a faculty of nursing.

Due to the mushrooming of nursing colleges, the quality of nursing education declined. Evidence of this is the decline in the average passing rate in the Nurses Licensure Examination (NLE) administered by the Board of Nursing to all graduates of the BSN program who want to serve as professional nurses. From 1999 to 2008, the number of Board passers continued to increase, indicating

the increased number of graduates of BSN nursing. However, the average passing rate stayed low.

Starting 2010, the CHED started to close down Colleges of Nursing whose graduates had dismal performance in the NLE. Likewise, news reports that graduates of Nursing had a hard time getting employed brought down the number of enrollees in nursing courses. This condition further closed down some nursing colleges. Consequently, there is currently, lesser demands for nurse educators in the Philippines.

Qualifications of Nurse Educators (Current and Expected)

Section 27, Article V of Republic Act (RA) 9173 or the Philippine Nursing Law of 2002 specifies the qualifications of the faculty of nursing teaching professional courses as one who must :

- Be a registered nurse in the Philippines;
- Have at least one (1) year of clinical practice in a field of specialization;
- Be a member of good standing in the accredited professional organization of nurses; and
- Be a holder of a master's degree in nursing, education, or other allied medical and health sciences conferred by a college or university duly recognized by the Government of the Republic of the Philippines.

The same provisions are reiterated by CMO 14 under Article VI which also provides that the faculty of nursing must be a Filipino citizen and having good moral character. With regards faculty members who teach other courses, i.e. basic sciences courses such as chemistry and mathematics as well as those teaching general education classes, Article VI of CMO 14 specify that they should be holders of at least a master's degree in their particular courses and should teach only courses in their respective area of specialization. This same section provides that should vacancies occur in these teaching positions within the year, substitute and replacement faculty should be those with the same qualifications as stated above.

In addition to the aforementioned qualifications, the dean of a college must have a master's degree in nursing. He/she must have at least five (5) years of experience in nursing. Compliance with requirements are ensured by CHED through the monitoring of Quality Assurance Teams.

Nursing Training Courses

Article VI, Section 11.6 of CMO 14 requires the colleges of nursing to have an “updated five – year faculty development program(FDP). The FDP consists of written activities and programs toward the development of the faculty for intellectual, personal and professional as well as moral and spiritual growth. The program may be in the form of: graduate studies, scholarship and research grants, in – service and continuing training programs and clinical skills enhancement of on official basis for at least two weeks per year”.

Provision of continuing education in nursing is controlled by the Board of Nursing of the Professional Regulation Commission. Training providers are required to enlist with and be accredited by the BON. Likewise, after accreditation, they have to apply for continuing education credits for each program that they conduct.

Continuing Education Courses Offered by UPM - CN

The University of the Philippines Manila, College of Nursing (the institution from which I come from) is a principal provider of continuing education programs in Nursing in the Philippines. It regularly conducts training needs analysis among colleges of Nursing nationwide and develops continuing education programs accordingly. We offer updates on health and nursing issues and trends so that the practice of nursing is continuously informed and equipped not only to elevate the practice of nursing but to better provide safe and quality nursing care.

We also provide capability building services to Colleges of Nursing to help them identify their needs, plan a program responsive to their needs and conditions and facilitate the achievement of these plans. Along this line, UPM –

CN is now assisting Cambodia through the University of Health Sciences, to develop their faculty capability towards upgrading the level of Nursing from Associate Degree in Nursing (ADN) to Bachelor of Science in Nursing (BSN).

Following is a list of some of the courses, which has been offered by the UPM – CN recently.

- Good clinical practice and health research ethics
- Disaster nursing preparedness and response
- Evidence-based practice of nursing and nursing education
- Basic emergencies and health promotion in the workplace
- Nursing Research
- Genetic counseling in the Philippines
- Mentoring Clinical Teachers
- A closer look at reproductive health, seminar
- Competency Based Nursing Curriculum Training
- Conducting an integrative review of literature
- Integrated Management of Childhood Illnesses
- Essential intrapartum and newborn care
- Meeting health care needs of a person with psychiatric problem: The nursing process framework
- Study designs for hypothesis testing: Interventions research

Research Development

Nursing Research in the Philippines is alive and active. Proof of the importance given to research in the nursing profession in the Philippines is the fact that faculty of nursing are required to have a Master of Arts degree in which the MA candidate has to conduct and defend a research project on a topic relevant to nursing. It should also be noted that Research is part of the undergraduate curricula. Thus, upon graduation, the beginning nurse is able to participate in and/or conduct research since all of them are exposed to the design and implementation of research.

Nurse specialty organizations sponsor research contests/conferences in order to encourage the conduct of nursing research in their respective areas of specialization. Presentation of the results/outputs of these researches are done through scientific sessions and/or poster presentations during their annual conventions.

To provide further push for nursing research, a group of nurses organized the Philippine Nurses Research Society (PNRS) which is now serving as a specialty organization of nurses who conduct research. Just recently, the Philippine Journal of Nursing, a peer reviewed journal, published a special issue dedicated to Nursing Research.

Challenges of AEC for Nursing Education in the Philippines

The Role of Culture

Culture affects one's way of thinking, acting and feeling. Culture affects the nurse's way of assessing, planning, providing and evaluating care. The role of culture is critical in the provision of quality nursing care. While we can say that ASEANs share some commonalities in culture, there are differences that affect aspects of providing nursing care. Areas to consider include interpersonal communication and relationship between patient and nurse as well as patient's relatives and significant others. Cultural differences can, likewise, critically affect teamwork among the health team members.

Thus, careful consideration of cultural issues and concerns should be undertaken as we prepare to pursue broader collaboration, especially in the area of providing for nursing and health.

Language Proficiency

Experience with the Japan – Philippines Economic Partnership Agreement (JPEPA) has taught us invaluable lessons on the importance of language proficiency, not only in the provision of transnational nursing care but more so, in complying with nursing rules and regulations such as taking nursing examinations and securing licensure. Under the JPEPA agreement, Filipino nurses had to take

and pass the Japanese nursing licensure examinations in given in Nihongo. The results have been a big disappointment despite undergoing 675 hours of Japanese language training and 141 hours of socio-cultural adaptation training. (Añonuevo, 2011). Likewise, proficiency with the Filipino language have been identified as an area of difficulty among foreign students both in the undergraduate and graduate levels, when they provide nursing care in the clinical areas.

Equivalency

Our college – the University of the Philippines Manila, College of Nursing – has been accepting graduate students from various Asian countries. Through the years that we have been doing so, a major area of concern that comes to fore is the issue of equivalency in our curriculum. This concern is not only whether the subject area has been taken up in the curriculum but also whether the desired level of competency has been achieved. In order to cope with the lessons, the foreign student must have enough background on the courses or subject matters that are covered in the curriculum.

This equivalency issue is likewise critical specially in the light of the differences in the levels of nursing services available in the ASEAN countries, i.e. Associate Degree Nursing (ADN) vs. Bachelor of Science in Nursing (BSN) since the competency requirements of nursing service based on the BSN program are not met by the nurse who graduates from the ADN program.

Separate Nursing and Midwifery Programs

While midwifery is technically, just an aspect or part of nursing, developments in the health history of some ASEAN countries have provided prominence in the practice of midwifery as independent from nursing. The Philippines is one of these ASEAN countries that have separate nursing and midwifery services. While there are efforts to unite these two groups, these efforts have been unsuccessful.

The concerns with regards this issue needs further study, very much like the equivalency issue.

References

- Abaquin, Carmencita M. (2012). "National Nursing Core Competency Standards". April 25, 2013.
- Añonuevo, Cora A. (2011). "Transnational Care: Expectations and Realities of Filipino Nurses under the Japan – Philippine Economic Partnership Agreement (JPEPA) Program". *Philippine Journal of Nursing*.
- Association of Deans of Philippine Colleges of Nursing, Inc. (2008). "Bachelor of Science in Nursing Curriculum Resource Units, 2nd Ed".
- Cirujales, Remegia M and Kuan, Letty. (2012). "Nurse Migration, Deployment, Enrollment and Board Passing Trends in the Philippines (1999 – 2008), *Philippine Journal of Nursing* Vol. 82, No. 1.
- Commission on Higher Education, Republic of the Philippines. (2009). "CHED Memorandum Order (CMO) No. 14, Series of 2009: Policies and Standards for Bachelor of Science in Nursing (BSN) Program".
- Divinagracia, Carmencita. (2006). "The Philippine Nursing Education Scene Today". *Mediscope*.
- Republic of the Philippines. "Republic Act (RA) 9173 or the Philippine Nursing Law of 2002".
- Sotejo JV and Beltran – Jackson MVG. (1965). "Learning Nursing at the Bedside". Quezon City, Philippines: University of the Philippines Press.
- University of the Philippines Manila, College of Nursing. (2010). "Catalogue of Information".
- University of the Philippines Manila, College of Nursing. (2006). "Competency Based Nursing Curriculum: A Model".

NURSING SERVICES IN PHILIPPINES

Maria Rita Villanueva-Tamse, RN, MN

University of the Philippine, Philippine General Hospital

Abstract

Nursing Service in the Philippines is characterized with dynamism and vigor in responding to the health care needs of the country. It plays an important role in ensuring the success of programs set by the Department of Health. With the excellent education offered by nursing schools in the Philippines, nurses are equipped with core competencies that make them in demand not only inside the Philippines but also internationally. The Philippine Professional Regulations Commission through the Board of Nursing monitors and accredits training programs that help the nurses with their continuing professional education. Specialty organizations and even health care institutions to sustain the global competitiveness of the nurses also offer several training programs. Effective delivery of nursing care however, is affected by the distribution of nursing human resource in the various regions and provinces in the country. The government has developed creative strategies to address this concern through the Registered Nurse for Health Enhancement and Local Service (RNHEALS) program. Nursing research has gained grounds through the support given by the government to promote health research and by the continuing importance given to this by the various nursing organizations and health institutions. Given this scenario in

Philippine Nursing Service the challenges posed in the context of the Asian Economic Community includes: language barriers, culture sensitive care, migration policies and credentialing requirements.

Overview of the Country

The Philippines is positioned on the western edge of the Pacific Ocean, on the southeastern rim of Asia, the Philippines. It is the second-largest archipelago on the planet, with over 7,107 islands with an estimated population of 94 million as of 2012. The growth rate: 1.9% per year. It has 80 provinces, 138 cities and 1,496 municipalities. Filipino is the national language, English the second and with a total of 180 ethnic groups and approximately the same number of languages. Approximately, 50.3% live in urban areas and of that, 44% live in slums. Both urban and rural poverty are high but steadily decreasing.

Malays make up the majority and 180 ethnic groups with approximately the same number of languages. There are tribes of indigenous peoples in mountainous areas throughout the country. The majority of the population is Christian and there is a Muslim minority concentrated in the south.

Nursing in the Philippines has evolved through the years aware of its responsibility in providing effective and efficient health care to all individuals, groups and community. Although the health status of Filipinos has generally improved in the last decades as evidenced by longer life expectancy at birth, lower maternal and child mortality rates, and improving albeit slow health outcomes seen in the management of many important diseases communicable and non-communicable, distribution and supply of continue to affect access to basic health care.

Given these health needs of Filipinos, nursing services continue to face the challenges given the existing human resources and working through the dual health system provided by the government. Over the years, several health programs were developed to ensure provision of relevant care in both the government and private sector, likewise in the community and hospitals.

Health Care Needs and Nursing Needs

At present, the Philippine health status indicators show a relative improvement in its health status reports. It has a population of ninety two million, with an annual population growth rate of 1.9%. The median age of Philippines is 23, making it a country of young people with strong labor force (World Health Statistics, 2011).

Figure 1. Philippine Population Pyramid, 2010

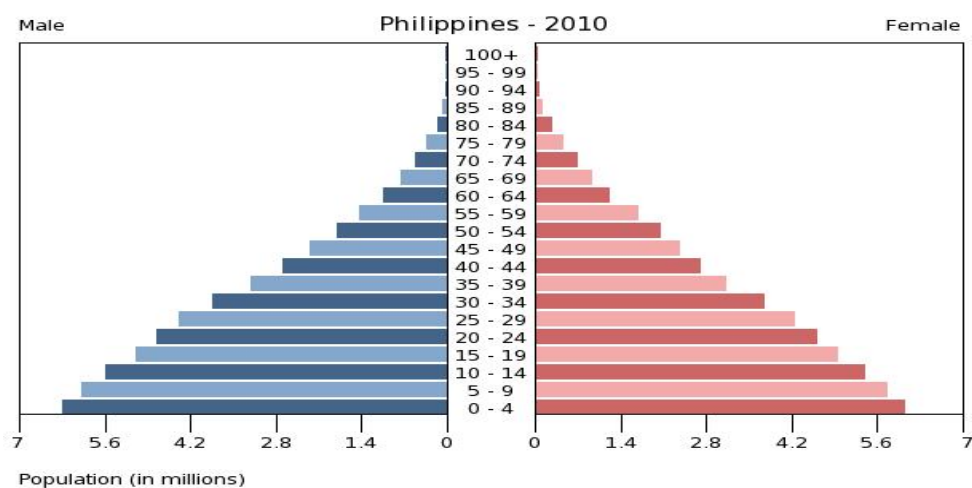

Communicable diseases continue to be major causes of morbidity and mortality. Pulmonary diseases like tuberculosis and pneumonia are leading causes of death. In addition, mosquito-borne diseases, such as malaria and dengue, continue to pose danger to the country, as malaria was the ninth leading cause of morbidity in the country in 2007. Life expectancy has improved as evidenced by the average life expectancy at birth for both sexes at 72 years in 2007. (Philippine Health Review, November 2011). However, the life expectancy rate may vary from one region to another depending on the poverty level of the area, nutrition and availability of health care in the area. However, in spite of this, a higher proportion of older persons in the general population is expected in the future.

With this trend comes the increase in the occurrence of degenerative diseases and disabilities associated with an aging population.

There is a slowing trend of reduction in child mortality and maternal mortality. Based on data from the Technical Working Group on Maternal and Child Mortality (UNDP, 2010). The infant mortality rate is at 24 per 1000 live births a steady decrease from 30 in 2003. Maternal mortality ratio that has remained well above 150 per 100,000 live births – meaning more than 3,000 mothers dying every year.

The leading cause of death in the Philippines is heart disease, with rates steadily rising from 70 per 100 000 population in 1997, to 90 per 100 000 population in 2005. This is followed by vascular diseases and malignant neoplasms (or cancer), with mortality rates of 63.8 and 48.9 per 100 000 population, respectively.

The National Nutrition and Health Survey in 2003-2004 revealed the prevalence rates of risk factors for cardiovascular diseases, such as coronary artery disease, stroke and peripheral arterial disease. Of the 4753 adults who participated in the nationwide study, 60.5% were physically inactive, and 54.8% of women were obese. Among males, 56.3% have a history of smoking. Alcohol intake among adults had a prevalence of 46%. These are only a few of the risk factors that contribute to the rising incidence of non-communicable diseases in the country. The rise in non-communicable diseases along with the existing prevalence of infectious diseases indicates the Philippines is in an epidemiologic transition characterized by a double burden of disease. This disease pattern indicates that even as degenerative diseases and other lifestyle-related illnesses are increasing, communicable diseases are still widely prevalent. (Philippine Health Review, November 2011).

Table 1. Leading Causes of Mortality

MORTALITY: TEN (10) LEADING CAUSES				
NUMBER AND RATE/100,000 POPULATION				
Philippines				
5-Year Average (2004-2008) & 2009				
CAUSES	5-Year Average (2004-2008)		2009*	
	Number	Rate	Number	Rate
1. Diseases of the Heart	82,290	94.5	100,908	109.4
2. Diseases of the Vascular System	55,999	64.3	65,489	71.0
3. Malignant Neoplasms	43,185	49.6	47,732	51.8
4. Pneumonia	35,756	41.1	42,642	46.2
5. Accidents**	34,704	39.9	35,990	39.0
6. Tuberculosis, all forms	25,376	29.2	25,470	27.6
7. Chronic lower respiratory diseases	20,830	24.0	22,755	24.7
8. Diabetes Mellitus	19,805	22.7	22,345	24.2
9. Nephritis, nephrotic syndrome and nephrosis	11,612	13.4	13,799	15.0
10. Certain conditions originating in the perinatal period	12,590	14.5	11,514	12.5
<p>Note: Excludes ill-defined and unknown causes of mortality</p> <p>* reference year</p> <p>** External causes of Mortality</p>				

Given the health care status of the Philippines, nursing service both in the community and in hospital must strengthen the integration of services. Service provision must be seamless to effectively address and improve the current health care indicators. Lifestyle diseases can be addressed by an effective health wellness and promotion program, which a nurse can provide. However, to effectively manage these diseases at the hospital level, nursing specialization becomes imperative. Likewise, improving life expectancy poses a challenge for the need to develop and operationalize nurse's capability to meet the needs of the older population.

Health care and nursing system

The Philippines has a dual health care system: the public and private sectors. Under this system, the Department of Health (DOH) is tasked to be the lead agency in health. It is responsible for providing national policy direction, develop national plans, technical standards, and guidelines on health; it also has regional offices in every region and maintains specialty hospital, medical centers, and regional hospitals. Under the decentralized or devolved structure, the Local government unit (LGU) with provincial, city, municipal, and barangay or village offices represents the state. Its mandate involves the provision of health care delivery at a primary and secondary level. The DOH Centers for Health and Development (CHD) are the implementing agencies in provinces, cities and municipalities. It provides guidelines on the implementation of national programs at the LGU levels. On the other hand, the provincial governments are responsible for supervising the provincial and district hospitals, while the municipal government governs the Rural Health Unit (RHUs) and Barangay/Village Health Stations (BHSs). The Department of Health also provides tertiary care through the DOH controlled specialty hospitals and tertiary medical centers.

The private sector on the other hand, is made up of large health corporations and smaller providers. Majority of these facilities are secondary and tertiary level hospitals, clinics, and other including health maintenance

organizations. These institutions are regulated by the Department of Health through system of standards and procedures through professional organizations including the Phil Health or the national health insurance. Out of the 1,700 hospitals in the country, it is estimated that 60% are private. However, the private hospitals and clinics are smaller when compared to government facilities, and their quality of service can vary widely.

Table 2. Number of hospitals by classification and ownership

Classification	Level 1	Level 2	Level 3	Level 4
Public/government	362	271	38	50
Private	417	405	183	70

Hospitals with higher service capabilities are highly concentrated in Region 3 and the National Capital Region (NCR) (Lavado, 2010, as cited in *Source Country Perspectives on the Migration of Health Professionals*)

The nursing system is likewise dual, with nurses found in both public and private facilities. In the public health system, nurses serve from the municipal to the city level. Nurses are managers of health centers and act as lead persons in all the Department of Health major promotive and preventive health programs.

Nursing serves as the backbone of hospital service. Nursing services provides 24/7 nursing care in all units of the hospital. Specialty nursing is present in most tertiary and training hospitals. The organizational structure of hospitals in the Philippine clearly shows the importance of nurses. In many of the tertiary hospitals, nurses participate actively in policymaking activities. Nursing programs developed in the hospitals illustrates the lead role played by nurse's i.e. clinical guidelines for cardiovascular patients, hospital safety program.

Although the health care system is extensive as described, its access, especially by the poor, is hampered mainly by high costs and physical and socio-cultural barriers. (Ronquillo, K., Elegado-Lorenzo, F.M., Nodora, R., 2005).

The Universal Health Care Program of the government, which was launched 2011 aims to ensure that every Filipino shall receive affordable and quality health benefits. This involves providing adequate resources – health human resources, health facilities, and health financing. With the Universal Health Care program is focused on improved access to quality hospitals and health facilities, which they will achieve in a number of creative approaches, which include upgrading facilities to accommodate increase of patient needing emergency care. Improve facilities to handle increasing number of patients with non-communicable diseases and to ensure capability in handling disaster and other emergencies.

Given the development in the health care delivery of the country, there is a need for nursing service to review its current system to strengthen its role in providing relevant services and rational human resources to meet the target of increased health care access and equity. Nursing service both in the community and in hospital must strengthen the integration of services.

Service provision must be seamless to effectively address and improve the current health care indicators. Lifestyle diseases can be addressed by an effective health wellness and promotion program, which a nurse can provide.

At hospital level, nursing specialization becomes imperative. Likewise, improving life expectancy poses a challenge for the need to develop and operationalize nurse's capability to meet the needs of the older population. It is also expected that technology will play an important role in making the program a success. Nurses therefore need to enhance their skills in this aspect of health delivery.

Level of Nursing Staff and Their Competency

The minimum requirement to practice nursing at a professional level in the Philippines is that of being a registered nurse (RN). All nurses in the Philippines are graduates of Bachelor of Science in Nursing from accredited and recognized schools offering the approved nursing program. Before a nurse can practice in the Philippines, they are required to pass the examination given by the Board of Nursing. Beginning nurses are expected to have the standard core competencies as approved by the Board of Nursing. They can be employed in both public and private health institutions Hospitals and other healthcare institutions however, employ high school graduates or nursing aide course graduates as nursing assistants.

Nurses practicing in hospitals are governed by the Standards of Hospital Nursing Practice, which was drafted by the Board of Nursing with the Association of Nursing Service Administrators of the Philippines.

In the area of nursing administration, a progressive career ladder is now being developed by the Association of Nursing service Administration of the Philippines.

Table 3. Categories of nurses, competency and regulatory requirements per level.

Category of nurses	Competency	Regulatory requirement
Staff nurse/community health nurse	11 core competencies	Passed the board examination, CHN – 1 year work experience
Head nurse	At least 3 years work experience	Relevant trainings
Nurse supervisor	At least 5 years work experience	Relevant clinical and management training, at least 9 units of higher education
Chief nursing officer	At least 5 years management experience	Master degree holder preferably in nursing administration

Nursing administrator and nurse executives are expected to have additional competencies as they go up the career ladder, thus the Association of

Nursing Service Administrators of the Philippines has developed a four level Nursing leadership and management course for this purpose.

Demand and Supply of Nursing Staff

As of 2010, the Philippines have 488,434 nurses. Currently the demand for nurses based on the number of positions in local/ national agencies is 27,160, for service government agencies, 17,547, for private agencies, 7,535 and for education 2,078. The international demand is approximately 150,885.

Based on the Service Delivery Profile in 2012 government health workers are unevenly distributed throughout the country and are concentrated in urban and more developed areas. Three regions, NCR, Regions III and IV-A (which are relatively close to metropolitan Manila), have a higher proportion of government health workers than more remote regions such as Mindanao. As in many other developing countries, there is geographic mal-distribution of employed nurses in Philippines, characterized by a strong correlation between place of education and place of employment (Lorenzo et al., 2007).

According to International Council of Nurses, in order to meet its population needs, the Philippine healthcare system should have a nurse to patient ratio of 1:4. Due to trend of continuing emigration of Filipino nurses, nurse to patient ratios in provincial and district hospitals are now one nurse to between 40 and 60 patients, which is a striking elevation from the ratios of one nurse to between 15 and 20 patients that prevailed in the 1990s (Galvez-Tan 2005, as cited in Lorenzo et al).

To address the distribution of human resources, the DOH has deployment programs that are aimed to increase supply of registered nurses, through the Registered Nurse for Health Enhancement and Local Service (RNHEALS) program, will work with families to guide them to services and facilities and financing benefits. The government gives these nurses honorarium amounting to 8,000 to 10,000 pesos per month. They are trainees and not regular staff of the hospital or government health facility where they are assigned. A Coordinator

assigned by the Local government or by the Department of Health hospital does supervision and monitoring.

Licensing

The Professional Regulations Commission (PRC) administers implements and enforces the regulatory policies of the national government with respect to the regulation and licensing of the various professions and occupations under its jurisdiction. The Professional Regulations Commission is also responsible for the enhancement and maintenance of professional and occupational standards and ethics and the enforcement of the rules and regulations. It administers and conducts the licensure examinations regulatory boards twice a year. The PRC-Board of Nursing monitors and enforce quality standards of nursing practice in the Philippines , exercise the powers necessary to ensure the maintenance of efficient, ethical, and technical, moral and professional standards in the practice of nursing taking into account the health needs of the nation.

Staff Development and Training Programs

To enhance the competence of nurses the Professional Regulations Commission Board of Nursing as per resolution no. 466, Series of created a Continuing Professional Education/Continuing Professional Development Council to assess, approved continuing education programs, and accredit continuing professional education providers. This is necessary to ensure the upgrading and updating of knowledge and skills of nurses resulting from scientific and technical advancements in the profession.

Various nursing specialty organizations are accredited providers, thus they develop appropriate continuing education programs for nurses. Likewise, the different health institutions both public and private have their Nursing Training departments, which plans and conducts staff development and training programs based on training needs of their nurses.

Some of the existing nursing specialties are the following: Mother and child nursing, Infection control nursing, Adult health nursing, Psychiatric and mental health nursing, Orthopedic nursing, Ophthalmic nursing, Occupational health nursing, Neurosciences nursing, Entrepreneur nurses, Toxicology nursing, Gerontology nursing, Cardiovascular nursing, and Perinatology Nursing.

The Department of Health through its Human Health Resource Bureau developed a Competency-Based Development Program towards specialization called the Nurse Certification Program towards Specialization on various nursing specialties. This is accordance with its mandate to develop learning opportunities to assist the Filipino nurses to attain international standards for quality service.

The Competency-Based Development program, which will be called the DOH Nurse Certification Program towards Specialization (NCPS), shall be developed and implemented by selected DOH Teaching and Training hospitals and supervised by the DOH-HHRDB.

Research Development

Research is one of the core competencies of nurses and as such is given high priority in terms of generating new knowledge and in improving the delivery of nursing care. The past several years saw the growth in nursing research, several nursing schools through its graduate programs have produced both quantitative and qualitative researches on nursing issues and concerns.

Last May 2013, President Benigno Simeon Aquino signed the Philippine National Health Research System Act of 2013. This law seeks to protect and promote the right to health of the people, instill health consciousness among them and improve the quality of life of every Filipino through research and development initiatives. Earlier than this milestone, the Philippine Nursing Research Society was born to provide a forum for dissemination and critique of nursing research, thereby stimulating interest in the scientific study of nursing phenomena and linking nurses with similar research interests.

Nursing research has also established a niche in the hospital system, tertiary hospitals has created research units to do clinical studies that are part of their quality assurance program and evidenced-based practice. Nursing organizations likewise, during annual convention or meetings include research presentations and contest to sustain the increasing interest of nurses. While in the past most researches are focused on nursing administration, current researches being undertaken are derived from the National Unified Health Research Agenda, collaboration of vital health agencies with for priority research areas: health financing, health governance , health regulations, and health delivery.

Quality improvement programs in various hospitals in the Philippines constitute a major research activity. International Accrediting bodies on the quality and safe services given to its patients have certified several major hospitals mostly in urban areas. The Philippine General Hospital, the premier tertiary hospital and National University Hospital was awarded the ISO 9001-2008 in 2009, three big private hospitals in Manila and Cebu, a southern province were given Joint Commission International certification and Accreditation Canada certified the Philippine Heart Center. In 2007, an Executive Order was signed by the President of the Philippine requiring all government agencies to ensure quality in their services, thus all government hospitals are now undergoing review of process towards International certification.

Challenges of Asian Economic Community to Philippine Nursing Service

Moving towards the target of the Mutual Recognition Arrangement on 2015, several challenges confront the different ASEAN countries. It becomes imperative that these challenges be addressed appropriately. Health care system similarities are observed including nursing practice however due to differences in education preparation, levels of care and other practices, it is important to look at the challenges of each country in relation to nursing services in other ASEAN countries.

Given the health care system and nursing system of the Philippines, the following are considered challenges:

- There is a need to develop harmonized standards of care that is culture sensitive. This can be partially achieved through sharing of best practices i.e. clinical guidelines disease condition.
- Ability to manage diverse nursing workforce
- Opportunity to establish research collaborations toward improved quality and safe nursing care
- Migration management that will include ethical recruitment and
- Knowledge of regulatory requirements and licensing.
- Communication efficiency

There are two important milestones in the nursing profession in the country worth mentioning that will further promote global competitiveness of Philippine nurses, first is the drafting of the Nursing Roadmap 2030, PRC-Board of Nursing led initiative in collaboration with the Philippine Nurses Association and other Specialty Nursing Organizations and the accredited Party List Ang Nars. The roadmap aims to foster accountability among all nurses by living the core values and manifest the qualities of a good nurse. It will promote and advocate for the collegiality and mutual respect across all disciplines and actively participate in the critical socio-economic and political issues of the country. Further, it will enforce quality standards in nursing education and nursing service and institutionalize sustainable organizational support for nursing progression. Likewise, the roadmap also aims to adopt local and global best practices in management of resources, ensure “positive practice environments “for nurses and to gain recognition as leader in primary health care.

The second milestone is the adoption of the National Nursing Core competency Standards that will guide the development of nursing in the country. The mandate includes development of standards of nursing practice in various settings in the Philippines, creation of a National Career Progression Plan for Nursing practice among others.

Conclusion

We are in interesting times, nursing is at the forefront of health care system globally, and nurses play an important role in ensuring success of various health programs of the different countries. This can be achieved through unity of vision, focus on clear directions, establishing alliances, through standard culture sensitive care, resource sharing, and strong research collaboration.

References

- Atanackovic, Jelena, Bourgeault, Ivy Lynn, Ogembo, Brenda, Chan, Jason
November. (2011). “Source Country Perspectives on the Migration of Health Professionals”.
- Department of Health, Philippines. (2010). “Administrative Order No. 2010-0036: The Aquino Health Agenda: Achieving Universal Health Care for all Filipinos”. Manila, DOH.
- Department of Health, Philippines. (2012). “Administrative Order No. 2012: Guidelines on the Department of Health Nurse Certification Program towards Specialization”. Manila, DOH.
- Health Service Delivery Profile Philippines. (2012). World Health Organization and Department of Health, Philippines
- Hospital Nursing Service Administration Manual. (1994).
- Professional Regulatory Board of Nursing Resolution. (2012). “Adopting and Promulgating the Competency Standards for Nursing Practice in the Philippines and the National Core Competency Standards”.
- Romualdez Jr., Alberto G, dela Rosa, Jennifer Frances E, Flavier, Jonathan David A., A. Quimbo, Stella Luz , Hartigan-Go, Kenneth Y., Lagrada, Liezel P., et al.(2011).Transition Vol. 1 No. 2. Asia Pacific Observatory on Health Systems and Policies. Manila, World Health Organization
- WPRO, 2011. Available on:
http://www2.wpro.who.int/asia_pacific_observatory/resources/Philippines_Health_System_Review.pdf

NURSING EDUCATION AND NURSING SERVICES IN SINGAPORE

Professor Sally Chan, BSc, MSc, PhD, Dip.Ed., RN, RMN

The scope of presentation is divided into 2 main parts: firstly, consider some challenges impacting nursing in Singapore. Secondly, discuss trends in nursing services and nursing education development.

Singapore facts (WHO, United Nation 2013 estimates):

Total population in Singapore is around 5,086,000. As of 2012, the total population of Singapore is 5.312 million people, of whom 3.285 million (62%) are citizens while the rest (38%) are permanent residents or foreign workers/students. Twenty-three percent of Singaporean citizens were born outside Singapore (i.e. foreign born citizens). There are half a million permanent residents in Singapore in 2012. The resident population does not take into account the 11 million transient visitors who visit Singapore annually. Singapore has a total land area of 714.3 square kilometers. Singapore is the world's fourth-leading financial centre, and its port is one of the five busiest ports in the world. The economy depends heavily on exports and refining imported goods, especially in manufacturing, which constituted 26% of Singapore's GDP in 2005. In terms of purchasing power parity, Singapore has the third-highest per capita income in the world. Gross national income per capita (\$) is 59,380 approximately. Singapore has a generally efficient healthcare system, even with health expenditure relatively low for developed countries. The WHO ranks Singapore's healthcare system as 6th overall in the world in its World Health Report. In general, Singapore has the lowest

infant mortality rate in the world for the past two decades. Infant mortality rate (/1000 lived birth) is 1.92. Life expectancy in Singapore is 80 for males and 85 for females, placing the country 4th in the world for life expectancy. Singapore has total expenditure on health per capita (\$) 2,787, and total expenditure on health as 4.6 % of GDP.

Population by age groups and sex (percentage of population), as reflecting the ageing population, the median age of the resident population went up further to 38.4 years in 2012 from 38.0 years in 2011. The proportion of Singapore residents aged 65 years and over rose from 9.3 per cent in 2011 to 9.9 percent in 2012, as demonstrated in the following figure:

Population by age groups and sex (percentage of population) for Singapore



Figure 1. Population by age groups and sex for Singapore

Healthcare system

Healthcare in Singapore is mainly under the responsibility of the Singapore Government's Ministry of Health. Singapore generally has an

efficient and widespread system of healthcare. Singapore was ranked 6th in the World Health Organization's ranking of the world's health systems in the year 2000. Singapore healthcare has been divided into primary healthcare service and hospitalization care. Primary health care service is presented in public sector 20% and private sector 80%. For hospitalization care, the ratio of public sector is 20% and private sector is 20%. Approximately 70-80% of Singaporeans obtain their medical care within the public health system. Overall government spending on healthcare amounts to only 3-4% of annual GDP.

	Public sector	Private sector
Primary healthcare services	20%	80%
Hospitalisation care	80%	20%

Healthcare professionals (2012)

As at end 2010, there were around 29,300 nurses in Singapore. 80% were Singaporeans and permanent residents, and the remaining 20% were foreigners. In the public sector, 22% of our nurses are foreigners from countries such as the Philippines, India and China. Close to 10% of our doctors come from Malaysia and some 14% come from India and other countries. The number of nurses in Singapore is 34,507 totally, this composed of 25,971 RN, 8,274 EN, 262 midwives, and 88 advanced practice nurses. The ratio of nurse/population is 1:150. The number of nurses per 1000 population is 7.1.

Principal causes of death

Deaths in Singapore offset the population increase from live births. In 2011, 18,027 people in Singapore died from various causes. The death rate was 4.5 deaths per 1,000 of the population, leading causes of morbidity and mortality are major non-communicable diseases such as cancer, which is the number 1 killer in Singapore (1 in 3 Singaporeans dies of cancer; 14 people die from cancer every day; 28 people are diagnosed with cancer every day), coronary heart diseases,

strokes, pneumonia, diabetes, hypertension and injuries. In 2011, cancer, ischemic heart disease and pneumonia together accounted for approximately 60% of the total causes of death. These diseases share many common risk factors such as smoking, obesity, physical inactivity and alcohol consumption.

Healthcare Challenges in Singapore

The challenge in healthcare system is the combined impact of a growing and ageing population on our capacity needs. Our population grew 25% over ten years and will continue to grow over the next decade. Healthcare services will need to grow in tandem. Our population is also ageing rapidly. By 2030, 1 in 5 Singaporean residents will be aged 65 and above. This is a threefold increase to 960,000 elderly, from about 350,000 today. The ageing population will be a strong driver for healthcare demand, as the elderly require a higher intensity of medical care. Studies have shown that they are about 4 times more likely to be hospitalized than younger Singaporeans. They are also likely to stay longer once hospitalized. This will have tremendous impact on overall healthcare demand in future. Already, we are seeing signs of capacity constraints across the system - from high bed occupancy rates to long waiting times for appointments.

Additionally, the ageing population also requires changes to how we organize and deliver healthcare. In the past, care was focused in the acute hospitals. This was not wrong, as our population was younger then, and our diseases were more episodic in nature. With increasing life expectancy and more sedentary lifestyles, we are faced with a growing burden of chronic diseases. We have therefore been shifting our focus from episodic care in the acute hospitals, to keeping people healthy and managing their chronic conditions in the community which is more effective and sustainable in the long-term.

Finally, we need to actively manage the rise in healthcare costs. Around the world, many governments are struggling to contain rising costs and Singapore too is not spared from the effects of global healthcare inflation. We thus need to

constantly innovate to stay cost-effective in how we deliver care, to ensure that healthcare remains affordable for everyone.

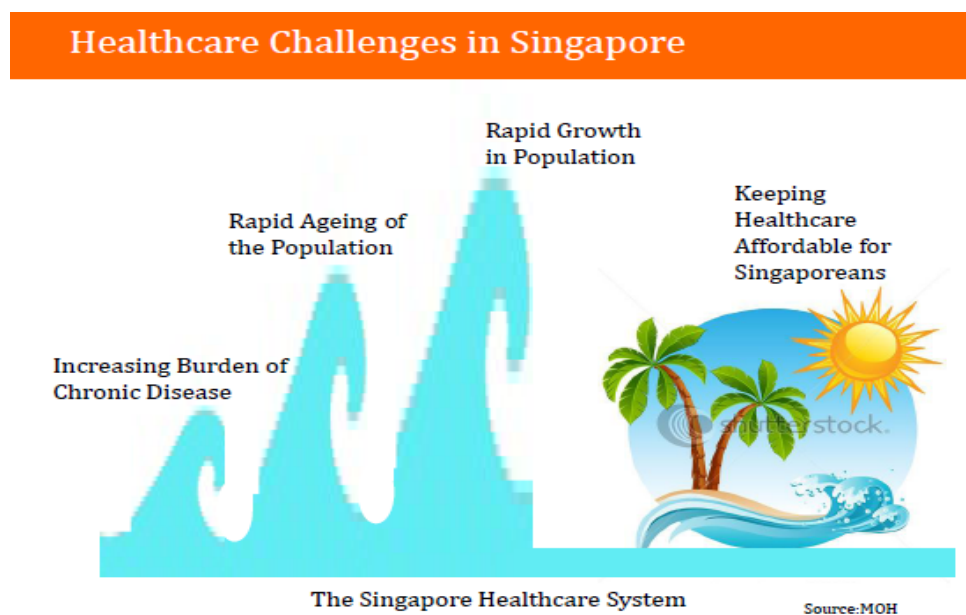

Figure 2. Healthcare Challenges in Singapore

Healthcare system transformation

The vision for transforming healthcare delivery in Singapore is to develop integrated Regional Health Services (RHS) to provide healthcare from prevention to palliation. Under the RHS concept, each region would be anchored by an acute-care hospital working in close partnership with other healthcare providers in the region, e.g. general physicians (GPs), polyclinics, community hospitals (CHs), nursing homes (NHs) and home care providers. Formalized partnerships, integrated clinical pathways and care coordinators working with a multi-disciplinary team over the patient's lifetime would help keep the care continuous, seamless and appropriate. Achieving this vision will require us to (i) significantly build up the ILTC and primary care sectors; and (ii) restructure our public healthcare system and strengthen the enablers and linkages between providers in each region to better integrate care and enable the entire system to work as it should, as presented in the following figure:

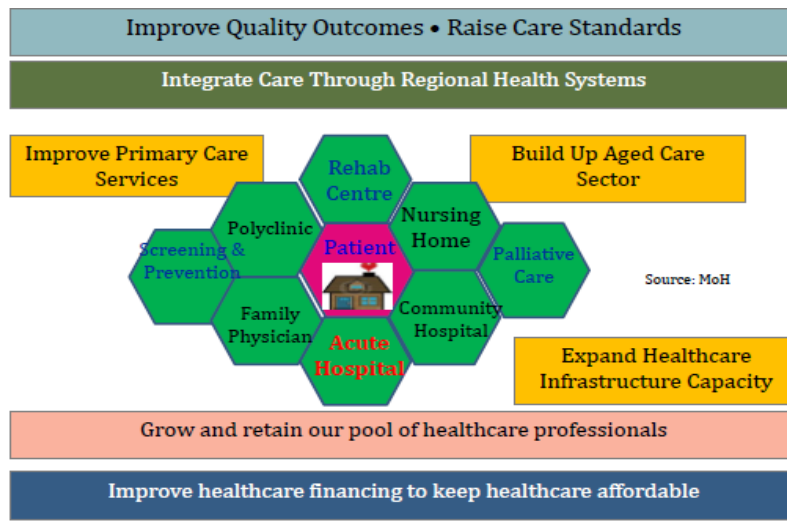

Figure 3. Improve Quality Outcomes

Models of Care

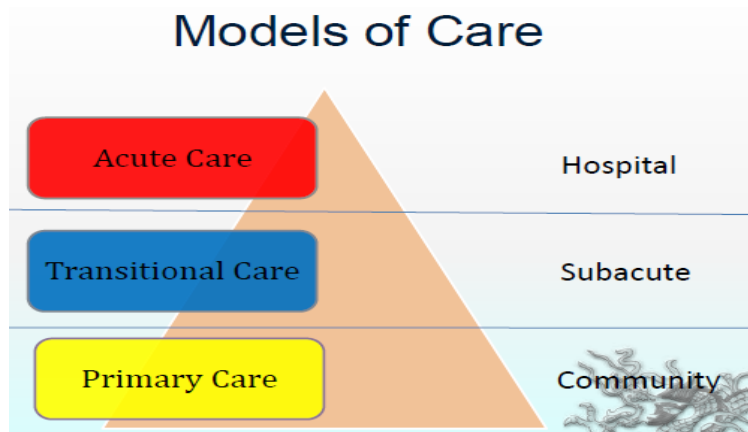

Figure 4. Models of Care

Singapore’s healthcare delivery system provides population the primary healthcare, hospital care, long-term care and other integrated care. Singapore has an island network of outpatient polyclinics and private medical practitioner's clinics to provide primary medical treatments, preventive healthcare as well as health education. Eighty percent of primary healthcare services are offered by 2000 private medical clinics; whereas the remaining is delivered by 18 government polyclinics.

Hospital care consists of inpatient, outpatient and emergency services. By contrast to primary healthcare, public hospitals provide 80% of hospital care. The public hospitals are structured by regions with five clusters: Alexandra Health Pte Ltd (AHPL), Jurong Health Services (JHS), National University Health System (NUHS) National Healthcare Group (NHG) and Singapore Health Services (SHS). There are two leading private providers are Raffles Medical Group and Parkway Health.

Pre-service Nursing Education in Singapore

A range of education options from basic certification to post-graduate studies is available when you choose nursing as your career. In order to equip you with the latest knowledge and evidence-based practice, the nursing training that you undergo is reviewed regularly to ensure that it keeps pace with evolving technology, a rapidly aging population and rising public expectations.

Registered Nurses: you need to acquire Diploma in Nursing/Diploma in Health Sciences (Nursing); Accelerated Diploma in Nursing; Degree in Nursing

- Bachelor degree - University
- Diploma - Polytechnics

Enrolled Nurses: you need to acquire Nitec in Nursing

- Certificate – Institute of Technical Education

Post-registration Nursing Education in Singapore

You can also study for a Bachelor of Nursing (Post-registration) degree awarded by an overseas university without leaving Singapore. The list of Bachelor of Nursing (Post-registration) courses accredited by the Singapore Nursing Board can be found as the below. The most recent addition is the Bachelor of Science (Honors) Nursing Practice offered by the University of Manchester, United Kingdom with the Singapore Institute of Technology.

- Advanced Diploma (specialty)
- Bachelor degree

- Master of Nursing
- Master of Science (Nursing)
- Doctor of Philosophy
- Other continuing nursing education programmes

Diverse Nursing Career paths for registered nurse

Management track: Nurses on the Management Track are tasked with responsibilities of maintaining a high level of operational efficiency as well as quality care and service within the patient care units. He/she will also be involved in reviewing and improving work processes, as well as supporting patient care delivery to create an integrated and seamless service for our patients.

Responsible for directing nursing activities, Nurse Managers supervise a staff that includes registered nurses, enrolled nurses, healthcare assistants and patient care associates. Motivating and developing staff under his/her care is a challenging yet critical task. State of the art technologies, such as e-Rostering and Trend Care systems are harnessed to plan work schedules and assign duties to nurses and aides to deliver high standard of care.

Nurses who chose to be in management are engaged in problem solving; conducting performance evaluations; overseeing the unit's budget; communicating and educating staff on policies and practice; and addressing concerns from patients and their families. They develop and implement strategies and programmes to achieve the highest standards in clinical, operational and financial matters. They must possess the ability to communicate effectively in many different settings. Leadership skills are essential as well as the ability to analyze a problem and make appropriate decisions. As a Nurse Manager progresses further, he/she will one day become an influential and outstanding nurse who is capable of leading the nursing profession to greater heights.

Clinical track

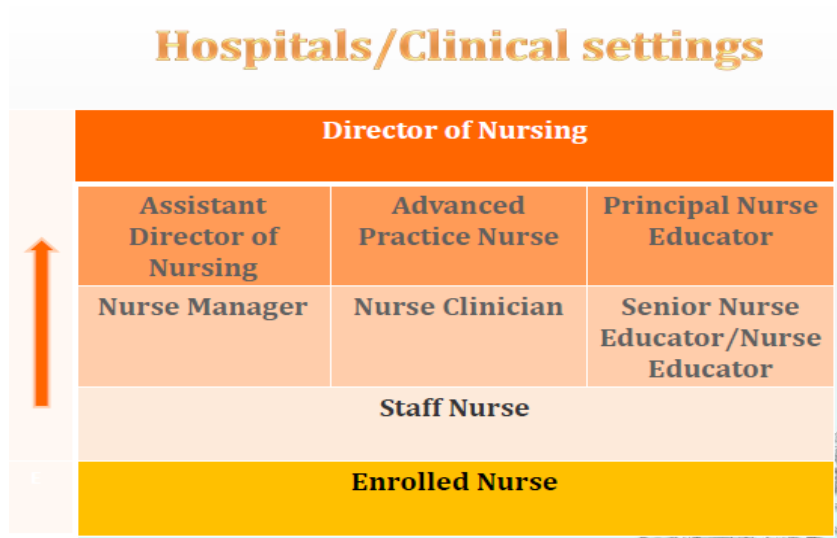

Figure 5. Hospital/clinical settings

Nurse Clinicians: nurses in NUH have the opportunities to specialize in the care of specific patient group within their chosen field of nursing. These Nurse Clinicians play a key role in the care management of patients with complex health needs through the provision of direct patient care, both in the inpatient and outpatient settings. To assist patients in restoring their quality of life within an optimum rehabilitative environment, Nurse Clinicians work closely with community services and support organizations to ensure continuity of care. Not only are they advocates and health educators for patients, families and communities, Nurse Clinicians are also involved in staff education, and in ensuring and developing nursing care standards and practices through evidence based and quality improvement initiatives.

Advanced Practice Nurse (APN): with the advent of the APN Register at the Singapore Nursing Board, nurses on the Clinical Track will be able to venture into new territories like never before. APNs are registered nurses who are prepared with Master degree in clinical nursing to provide preventive and acute health-care services to individuals. They work independently and collaboratively with the healthcare team. Their scope of care extends beyond that of traditional

nursing and encroaching on medical practice. APNs are authorized to take health histories and provide complete physical examinations; diagnose and treat many common acute and chronic problems; interpret laboratory and diagnostic results; furnish and manage medications and other therapies; provide health teaching and counseling to support healthy lifestyle behaviors and prevent illness; and refer patients to other health professionals as needed.

Nursing Specialties: as nursing positions expand beyond the traditional hospital nursing roles, nurses have increased options and flexibility. The wide selection of patient care units and medical specialties offers a career enhancing setting for the professional nurse who desire to develop in bedside nursing. Opportunities exist in these nursing specialties and subspecialties. *Nursing specialties* are included: Critical Care, Emergency, Medical, Obstetrics & Gynecology, Oncology, Orthopedic, Pediatric, Perioperative, Surgery. *Nursing Sub-Specialties* are: Breast Cancer, Diabetes, Gastrointestinal, Gerontology, Infection Control, Neuroscience, Ophthalmology, Pain, Psychological Medicine, Rehabilitation Medicine, Renal, Respiratory, Wound/Stoma/Continence

Education track: Nurses on the Education Track have an overarching responsibility to develop and enhance the professional knowledge, clinical skills, and attitudes of student nurses and registered nurses within the Nursing Department. Nurse Educators design, develop and organize relevant training programmes with the intent of providing quality patient care to our patients and in alignment with the hospital's mission of providing excellent service to our patients.

The role of the Nurse Educators is that of a teacher, mentor, counselor, facilitator, and coordinator for nurses to transit and phase in smoothly and safely into the clinical practice area and functions. NUH offers diverse and challenging clinical experiences to nursing students as they advance in their education. The Nurse Educators collaborates with teaching institutions to provide comprehensive educational opportunities. These educational experiences provide nursing students opportunities to work alongside other professionals in a multidisciplinary healthcare environment.

Nurse Educators in NUH are equipped with capabilities to deliver programmes such as induction courses for newly graduated Registered Nurses, Enrolled Nurses and Healthcare Assistants and new recruits, certification courses such as Basic Cardiac Life Support (BCLS) and Patient Safety Workshop. They use varied teaching and learning strategies such as lectures, demonstrations, role-play, reflection, critical thinking, concept mapping and problem-based learning to achieve clinical and professional competency outcomes. In order to be a Nurse Educator in NUH, one needs to have sound knowledge, good clinical skills as well as an aptitude and passion for teaching.



Figure 6. Academic settings

Other careers options are: Case Manager, Clinical Trial Coordinator, Community Care Coordinator, Entrepreneur, Policymaker, Research Assistant/Fellow, School Nurse.

Changing landscape in 21st century nursing

- Globalization of the world's economy and society
- Changing demographic profile
- Changing status of women
- Increase access to education
- Increase employment selection
- Changing characteristics of current generation of nursing students

Nursing workforce

- An estimated 35 million nurses make up the greater part of global health-care workforce
- Nurses make a substantial contribution to health-delivery systems in primary care, acute care and community care settings.

Exciting time for nursing



Our health system will need:

- Prevention
- Chronic care management
- Care coordination
- End-of-life care

Perfect role for nurses!

The infographic features a blue rounded rectangle on the left containing the text 'Our health system will need:' followed by a bulleted list of four items: Prevention, Chronic care management, Care coordination, and End-of-life care. To the right of this text is a photograph of four healthcare professionals in blue scrubs attending to a patient in a hospital bed. Below the photograph, the text 'Perfect role for nurses!' is written in a bold, black font. The background of the infographic is light blue with a faint map of Southeast Asia in the bottom right corner.

Figure 7. Role of Nurses

New models of care:

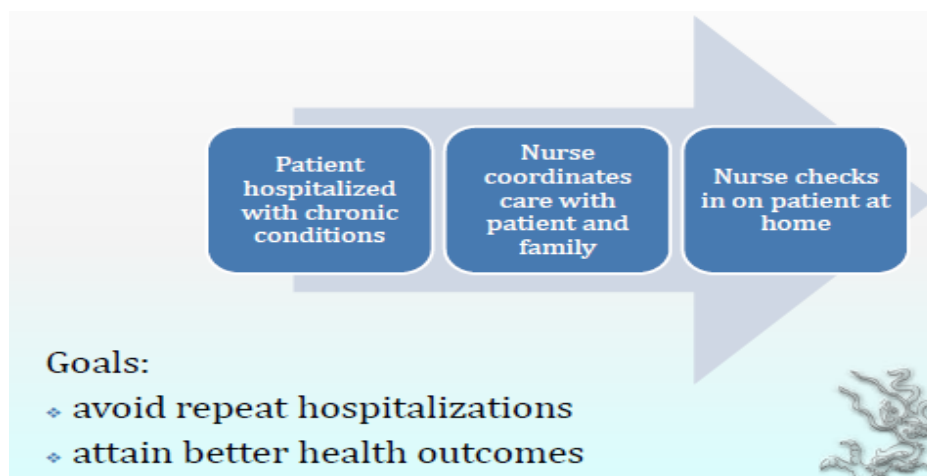

Figure 8. New models of care

Nursing workforce: there are many challenges such as unprecedented demand and shortage, and nurses educated at various levels. Therefore, it has a question on “How to nurture nurses for the 21st century?” and “HOW CAN we prepare them for their PRESENT AND FUTURE roles?”

Transformative Nursing Education

Higher education strives to transform students by opening their minds to different world views. Through integration of modern science into the curricula at university-based schools, the reforms equipped health professionals with the knowledge that contributed to the doubling of life span during the 20th century. By the beginning of the 21st century, however, all is not well. Glaring gaps and inequities in health persist both within and between countries, underscoring our collective failure to share the dramatic health advances equitably. At the same time, fresh health challenges loom. New infectious, environmental, and behavioral risks, at a time of rapid demographic and epidemiological transitions, threaten health security of all. Health systems worldwide are struggling to keep up, as they become more complex and costly, placing additional demands on health workers.

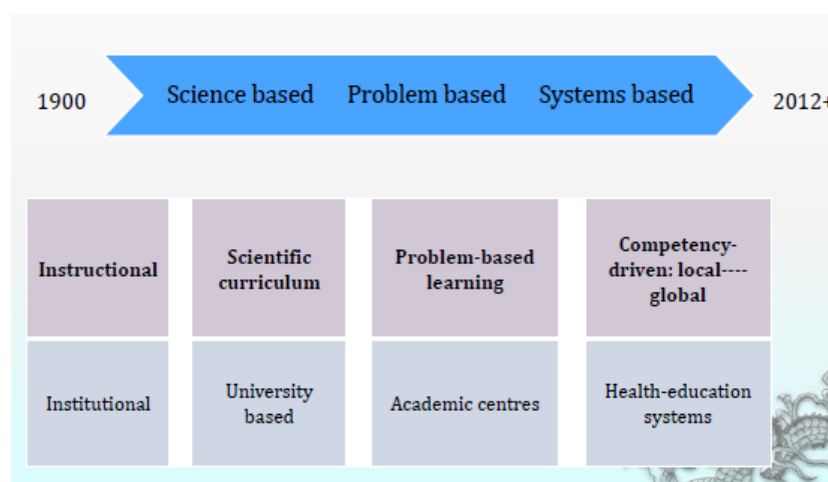

Figure 9. Three generations of reform in Health care professional education (The Lancet, 2012)

Redesign of professional health education is necessary and timely, in view of the opportunities for mutual learning and joint solutions offered by global interdependence due to acceleration of flows of knowledge, technologies, and financing across borders, and the migration of both professionals and patients. What is clearly needed is a thorough and authoritative re-examination of health professional education, matching the ambitious work of a century ago. That is why this Commission, consisting of professional and academic leaders from diverse countries, came together to develop a shared vision and a common strategy for postsecondary education in medicine, nursing, and public health that reaches beyond the confines of national borders and the silos of individual professions.

The Commission adopted a global outlook, a multi-professional perspective, and a systems approach. This comprehensive framework considers the connections between education and health systems. It is centered on people as co-producers and as drivers of needs and demands in both systems. By interaction through the labor market, the provision of educational services generates the supply of an educated workforce to meet the demand for professionals to work in the health system. To have a positive effect on health outcomes, the professional education subsystem must design new instructional and institutional strategies.

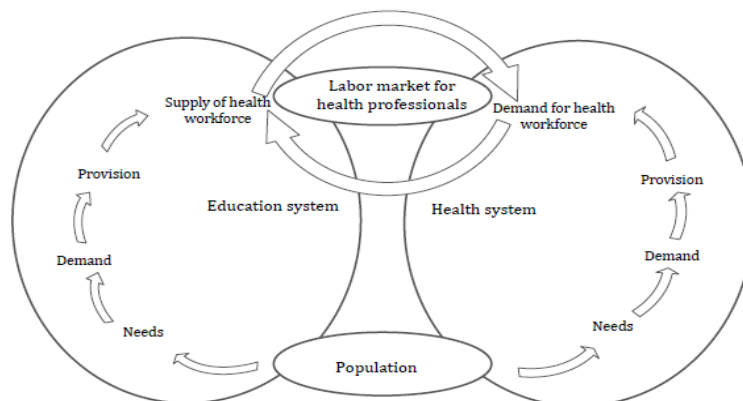

Figure 10. Academic Medical Centre Systems Framework (The Lancet, 2012)

Transformative learning is the proposed outcome of instructional reforms; interdependence in education should result from institutional reforms. On the basis of these core notions, the Commission offers a series of specific recommendations to improve systems performance. Instructional reforms should: adopt competency-driven approaches to instructional design; adapt these competencies to rapidly changing local conditions drawing on global resources; promote interprofessional and transprofessional education that breaks down professional silos while enhancing collaborative and non-hierarchical relationships in effective teams; exploit the power of information technology for learning; strengthen educational resources, with special emphasis on faculty development; and promote a new professionalism that uses competencies as objective criteria for classification of health professionals and that develops a common set of values around social accountability. Institutional reforms should: establish in every country joint education and health planning mechanisms that take into account crucial dimensions, such as social origin, age distribution, and gender composition, of the health workforce; expand academic centres to academic systems encompassing networks of hospitals and primary care units; link together through global networks, alliances, and consortia; and nurture a culture of critical inquiry.

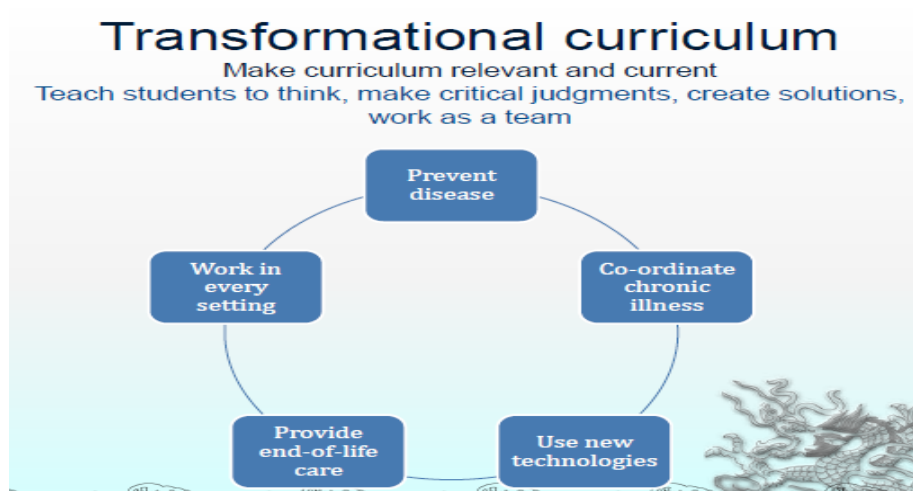

Figure 10. Transformational Curriculum

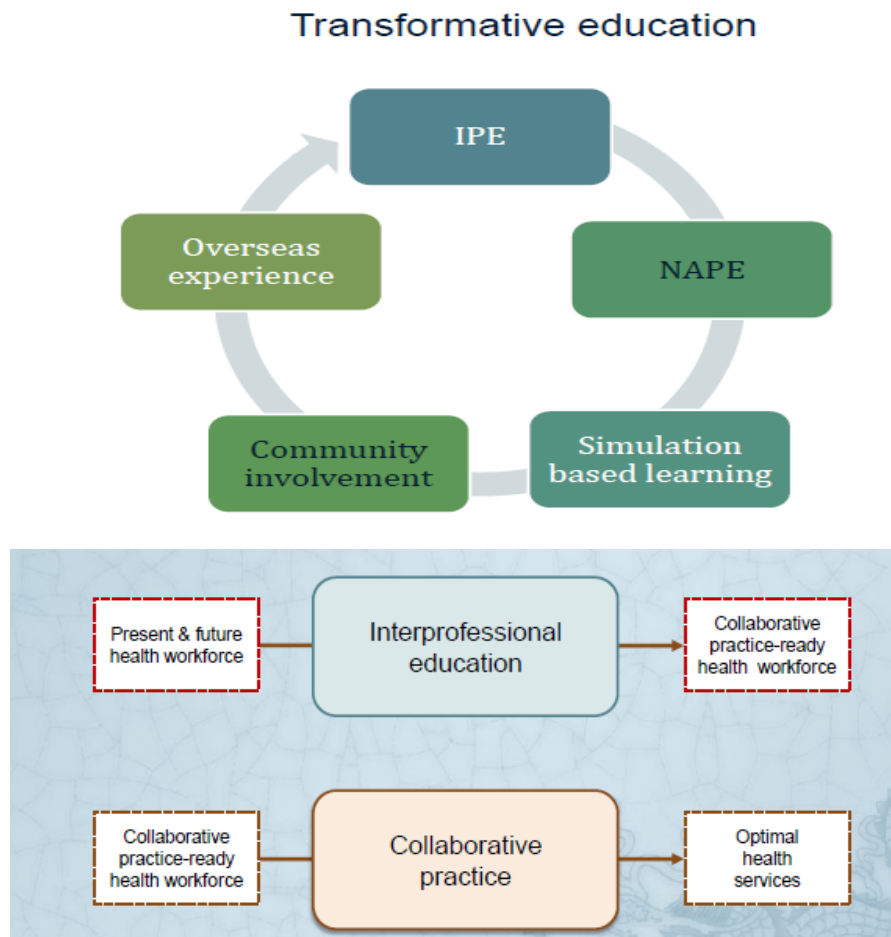

Figure 11. Transformative education

Inter-Professional Education (IPE)

Inter-Professional Education has the objective to prepare a “collaborative practice-ready” health workforce, where students from different healthcare profession learn about, from and with each other.

In NUS: five academic units involved:

- Alice Lee Centre for Nursing Studies
- Yong Loo Lin School of Medicine
- Department of Pharmacy
- Faculty of Dentistry
- Department of Social Work

Collaborative ready healthcare professionals

Nursing education methods: *“It’s not so much what is poured into the student, but what is planned, that really counts.”*

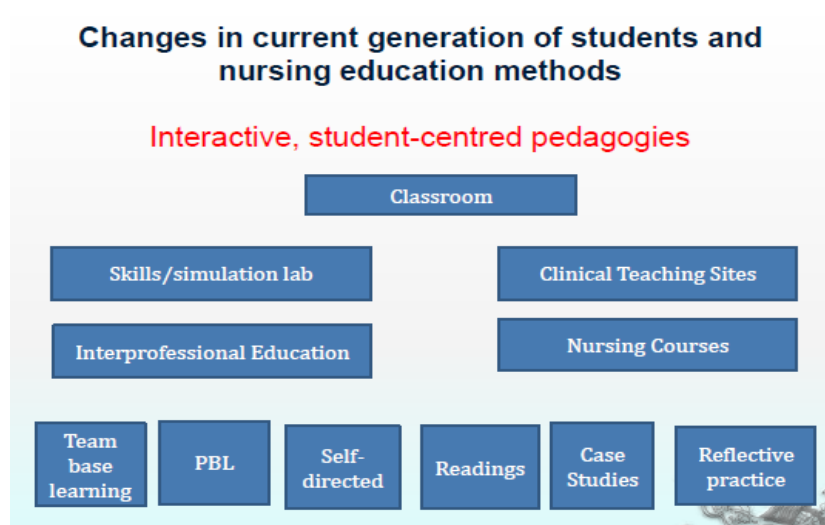

Figure 12. Transformative education

Education in Nursing is Transformative Education which has changes in current generation of students and nursing education methods by focused on Interactive, student-centered pedagogies. Simulation based learning: High fidelity simulators, standardized patients, inter-professional simulation. Moreover, we focused on Education-practice Gap and Practice-education Gap.

NUS and National University Hospital Collaboration: this collaboration has the purpose in addressing gaps, bridges to link nursing scholarship to nursing practice through:

- Research Utilization
- Collaboration
- Integration of theory, research and practice

In addition, an enriching learning experience - Longitudinal patient follow up in the community.

Health care boundaries are rapidly changing. Shrinking borders; we can be almost anywhere in the world in 36 hours. Nurses need to plan for preparedness

for roles in global health. Contribute to saving lives by improving health throughout the world:

- Building alliances
- Communicating ideas and best practices

There are challenges that “How can we develop new models for global health?”

To overcome these challenges, we need:

- Collaboration between schools of nursing
- Joint research projects
- Faculty and students exchanges
- Transformational education

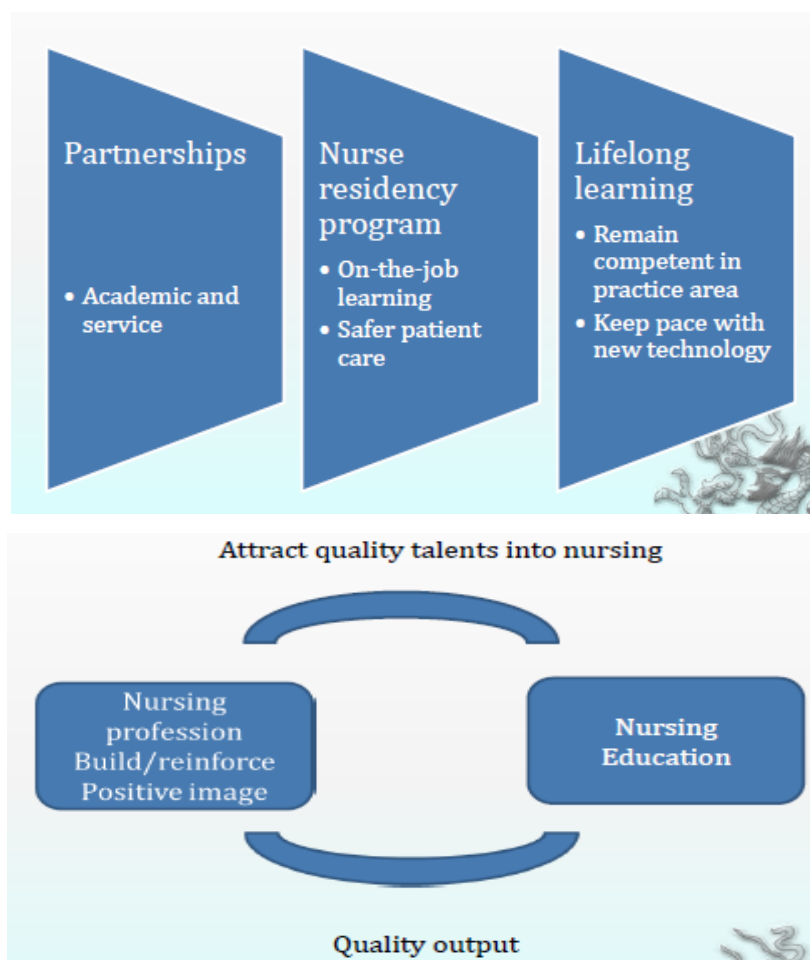

Development of Advance Practice Nurses

Advanced Practice Nurse (APN) is a registered nurse who has acquired the expert knowledge base, complex decision-making skills and clinical competencies for extended practice. Role and responsibility are presented as the following:

- Work collaboratively with doctors and other healthcare professionals to provide complex nursing care to patients;
- Use advanced assessment and clinical skills to anticipate and manage complex situations;
- Administering therapies for managing of actual and potential health issues;
- Participate in the development of evidence-based practice, integrating theoretical and practice-based knowledge to influence the development of nursing, health practice and policy at local and national levels, and
- Participate in professional activities to promote the advancement of nursing and health care.

The development of APN in Singapore is as a national planning. The Master level of nursing is needed for the preparation. The other requirements are the 2-year full time study and also sponsored by employers. The areas of specialization provide the adult health, a mental health, an acute care and a pediatric care. The study models are divided into 3 models which are a core advanced practice models, generic graduate models, and a specially models. Master Degree in Nursing:

National Planning Considerations for APN Development, not only one-year internship will be need before graduate APN but an accreditation for APN will be needed too.

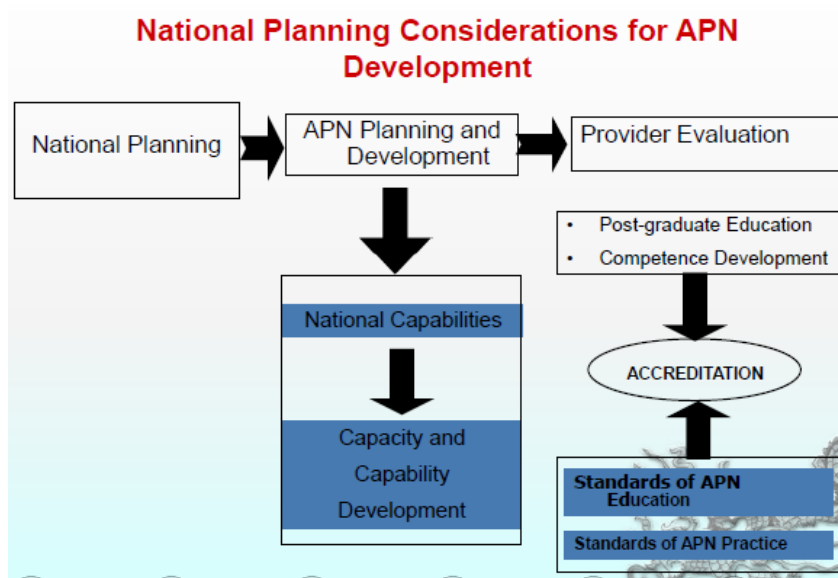

Figure 13. National Planning Considerations for APN Development

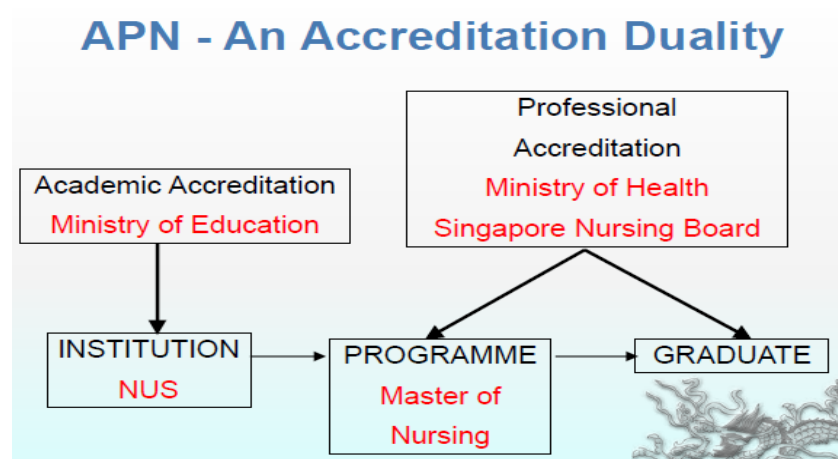

Figure 14. APN- An Accreditation Duality

Nursing Research Development

Doctor of Philosophy (PhD): this program has established to develop graduates who: are able to independently undertake research to advance nursing science; has drive for evidence-based nursing research and practice; and develop creative and strategic approaches to lead the nursing profession nationally and internationally. Moreover, it still needs the essential elements in health care research that are: Meeting the health care needs; Multidisciplinary and client

centre approach; University and clinical partnership. In term of university and clinical partnership, the partnership has the goal as the following:

Partnership Goals: To develop new knowledge in patient care, To develop and test new approaches to improving care, To disseminate ways to care for patients, and To promote quality of care for patients.

Expanding education capacity : Evidence: Education makes a difference:

Aiken (2003) study confirms the link between education level and health care outcomes: *Higher level of education of hospital's nursing staff resulted in lower mortality and lower incidence of failure to rescue.*

Global standards for nursing and midwifery (WHO, 2009)

- A more highly educated nursing workforce not only improves patient safety and quality of care but saves life.
- The future of nursing and midwifery education lies in good preparation at the professional, first-degree level.

Expanding education capacity:

“If you think education is expensive, try ignorance.” Derek Bok

“Among the few things more expensive than education these days is the lack of it.”

Developing Educational Mobility

In order to expanding education capacity, Singapore needs to develop educational mobility. Regarding international research on the effects of educational regimes on intergenerational mobility suggests that Singapore's education system possesses characteristics that tend to decrease intergenerational mobility. We have to create the strategies to bridge over this problem. The strategies need to be driven the professional up, have a greater pool of applicants for graduate programmes, and increased baccalaureate education.

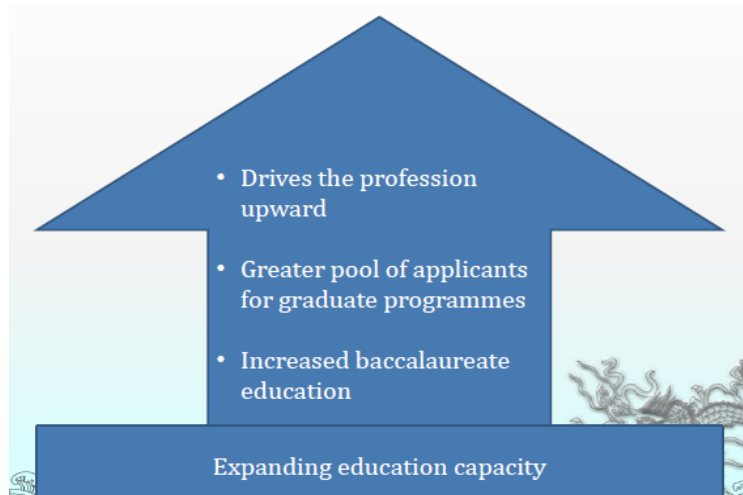

Figure 15. Expanding Education Capacity

Nursing development in ASEAN

Regarding the objectives of the ASEAN Framework Agreement on Services, which are to enhance cooperation in services amongst ASEAN Member Countries in order to improve the efficiency and competitiveness, diversify production capacity and supply and distribution of services of their services suppliers within and outside ASEAN; to eliminate substantially the restrictions to trade in services amongst ASEAN Member Countries; and to liberalized trade in services by expanding the depth and scope of liberalization beyond those undertaken by ASEAN Member Countries under the General Agreement on Trade in Services with the aim to realizing free trade in services. In order to develop nursing profession under this condition, we are necessary to:

Expand regional collaboration:

For the instance of collaboration;

15th EAFONS which is the East Asian Forum of Nursing Scholars was first launched in 1997 in Hong Kong to provide a regular regional forum for doctoral-prepared nurse academics and their students. Since 1997, annual forums have been held in Hong Kong, Japan, South Korea, Taiwan, Thailand and the Philippines. Singapore will be hosting the event for the first time in 2012.

APRS in 2012: the Asia Pacific Research Symposium 2012 is the premier nursing and health research conference for research conducted in the Asia Pacific Rim. The inaugural symposium was held at Griffith University, Australia in 2008 and followed in 2010 by the Taipei Medical University, Taiwan.

In term of collaboration in research development: Journal of Nursing Interventions (JNI) that is the official journal of the East Asia Forum for Nursing Scholars. The mission of JNI is for: 1) Peer-reviewed journal, 2) Delivered initially through the International Journal of Nursing Practice as a supplement of the journal. JNI published a special issue for ASEAN countries.

NURSING EDUCATION IN VIET NAM

Luong Van Hoan

*Head of Nursing Department, Faculty of Nursing-Medical Technology,
University of Medicine and Pharmacy at Ho Chi Minh City*

Nursing Educational System & Curricula

General information

Lying on the eastern part of the Indochinese peninsula, Vietnam is a strip of land shaped like the letter “S”. The country’s total length from north to south is 1,650km with the total of mainland territory of 331,211.6 sq.km. The coastline is 3,260km long and the inland border is 4,510km. Vietnam is also a transport junction from the Indian Ocean to the Pacific Ocean. The capital of Vietnam is Hanoi of which the administrative Units of Vietnam are divided into 63 provinces and cities nation-wide. The Vietnamese climate is tropical with monsoons. The population of Vietnam is 91,519,289 (M: 49.2%, F: 50.8%) (July 2012 est.) with ethnic groups such as Kinh 85,7%, Tay 1,9%, Thai 1,8%, Muong 1,5%, Móng,2%, Nung 1,1%, others 5,3% (1999 Census). The primary spoken language is Vietnamese. The religious groups in Vietnam are Buddhist 9.3%, Catholic 6.7%, Hoa Hao 1,5%, Cao Dai 1.1%, Protestant 0,5%, Muslim 0,1%, none 80,8% (1999 census). Life expectancy is 69.95 years for male and 75.16 years for female (2012 est.).

Vietnam has 64 provincial health services, 864 hospitals, 895 polyclinics, 35 special clinics, 76 maternity homes, 11,161 health stations and 184,440 inpatient beds. There is a total of 241,498 health care personnel: MD:

47,587, Nurses: 48,157, Midwives: 16,218, Pharmacists: 6,266, Assistant doctors: 48,325. The number of MD/10,000 inhabitants is 5.88 and number of nurses /10,000 inhabitants: 5.95. The leading causes of deaths are cancer 25%, stroke 20%, ischemic heart disease 6%, Chronic Obstructive Pulmonary Disease 4%, lower respiratory infections 4%, tuberculosis 2%, road injuries 2%, cirrhosis 3%, HIV/AIDS 3% and diabetes 3% (Health Statistical Profile).

The Vietnamese government’s vision on health care service

Health care services must be productive and in National defense. The prevention of disease must be the principal activity of health care services, to combine treatment with prevention, western medicine with traditional medicine and rely on all people for the development.

Organizational chart of the health sector of Vietnam

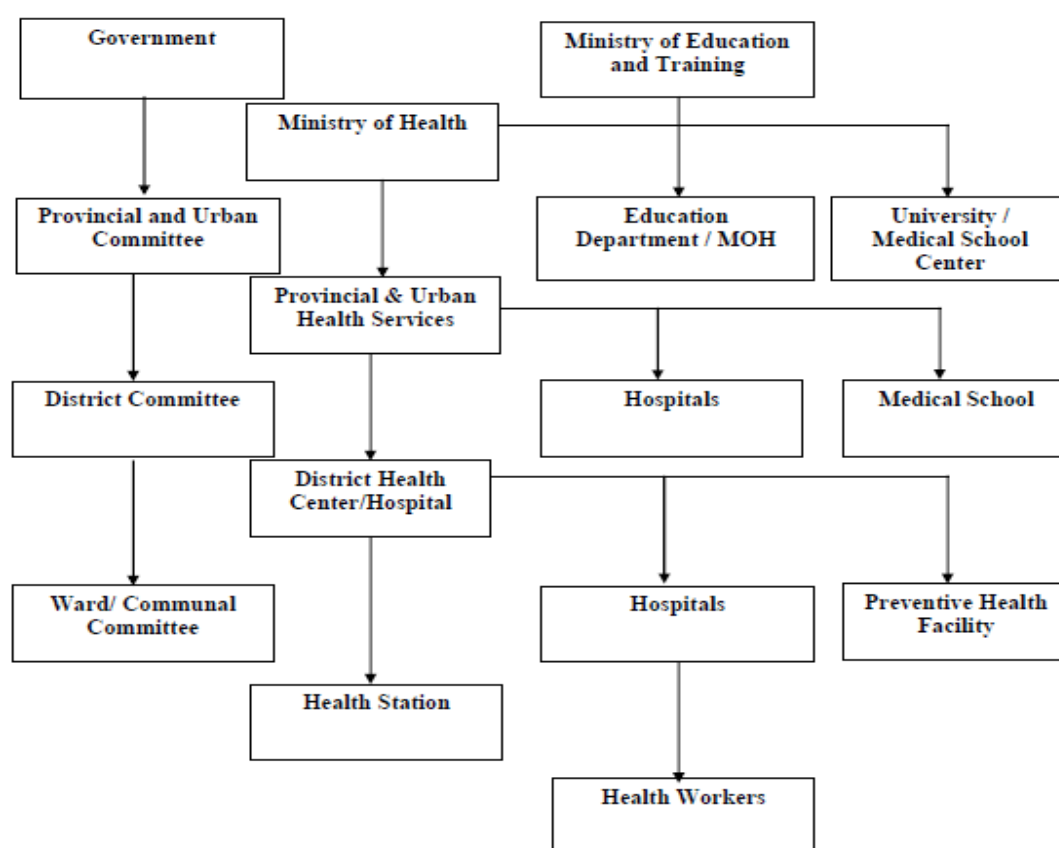

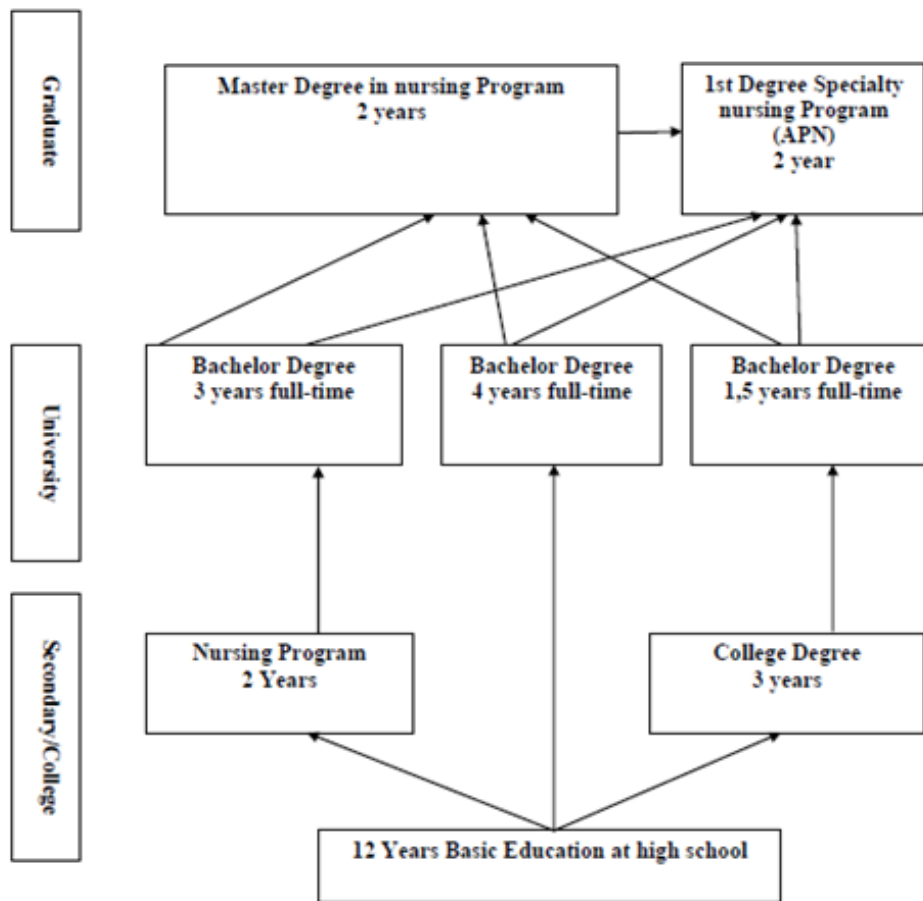

Figure 1. Nursing Education System

- The training curricula have been renewed step-by-step in order to integrate into ASEAN.
- There is a training program in Master of Science in Nursing and more recently, the first degree specialty nursing for graduate education in nursing.
- The national curriculum committee established by the Ministry of Health and the Ministry of Education and Training has the nurse's participation
- The framework curricula for training degrees in nursing are:
 - + 2-year nursing curriculum (secondary level)
 - + 3-year nursing curriculum (Diploma level)
 - + 4-year nursing curriculum (Bachelor level)

Post Graduate

- + 2-year nursing curriculum (Master level)
- + 2-year nursing curriculum (1st degree specialty)

Education and professional development

Nursing Training Institutions System:

There are universities, colleges, secondary nursing schools at provinces and cities nation-wide with many degrees as follows:

- Graduate school: 4
- Undergraduate school: 19
 - There are 14 governmental training institutions.
 - There are 5 non-governmental training institutions.
- College : 39
- Secondary school: 88
- University of Medicine and Pharmacy at Ho Chi Minh City is the first to offer master degree in nursing in Vietnam.
- Hanoi Medical University in collaboration with Gothenberg University of Sweden offers one master course in pediatrics.
- University of Medicine and Pharmacy at Hue City, Nam Dinh University of Nursing, Can Tho Medical University, and Pham Ngoc Thach Medical University offer the 1st degree specialty program in nursing.
- From 2012, institute of pediatric health research under national pediatric hospital has offered the 1st degree specialty nursing program in pediatrics.
- Some non-governmental schools offer secondary level in nursing.

Table 1. Institutions for training nursing human resource

Institution	2008		2020	
	Government	Non-government	Government	Non-government
Graduate	02	0	10	0
Undergraduate	11	3	20	10
College	29	0	60	20
Secondary	67	7	0	10

Qualification of nurse educator (Current and Expected)

Current:

There are:

- Ph.D degree : 4 (with 2 in nursing, 2 in public health)
- Master degree: 226 (with 60 in nursing, 166 in public health).
- Bachelor degree: 657
- Diploma degree: 119
- Secondary degree: 204

Expected:

Table 2. Human resources in period of 2015-2020

Year	2015	2020
Master degree	100	500
PhD degree	15	50

- The nurse who graduates from nursing school teaches for nurse student
- Provide additional specialized courses to train nursing specialization for staff nurses and nurse teachers.

- Increase the recruitment of students in nation-wide master courses through Vietnamese training program or combination training program with other countries in the world.

Nursing training course (requirements for nurses and nurse teacher)

Short-term regular training to meet the requests of medical units as well as continuing education for nurses

- Nursing management and leadership
- Open clinical teaching workshop for nursing faculties and staff nurses in hospitals
- Improve and promote nursing skills for staff nurses in hospitals
- Train novice/new nurse teachers for other nursing schools
- Open courses on scientific research in nursing for nurse teachers and staff nurses.
- The nurse is required to complete 24 hours every year for continuing education.
- Provide the nurse with certificate to participate in specialization nursing workshops or courses at nursing schools, hospitals, or in combination with other universities in the world.
- Nursing symposium in collaboration with other universities in the world.

Research development

- Nursing research has been developed in recent years as a result of Master Courses in nursing, workshops on nursing research organized by Vietnam Nurses Association (VNA), and hospitals.
- The areas of nursing research are mostly in community health survey. The experimental study should be more considered and developed in the future.
- The faculty has partnerships with many universities, hospitals and international associations to do research. Through this cooperation, the lecturers' quality training, learning and research level improved.

- Nurses and nurse teachers are required to do research every year and report their research results in their own hospitals and other ones.
- Master students are required to conduct nursing research for their thesis at the end of the course.
- Begin to develop center for nursing research at some universities
- Organize many workshops on nursing research process for staff nurses and nurse teachers.
- Begin to develop evidence-based teaching and clinical nursing practice.

Challenges of AEC for nursing education in Vietnam

Training

- Renovate traditional nursing curriculum and apply the competency-based nursing curriculum in nursing education
- The nursing educational system has not been standardized due to lack of qualified nursing teachers.
- Nursing procedures have not been standardized and developed as a national unification standard.
- Nursing curriculums have not been standardized
- Improve nursing education standards and health care services so as to integrate into ASEAN and in the world
- Professional standards for nursing practice have not been met according to the World Health Organization.
 - Educate competency-based nurses
 - The minimum level of the nurse is diploma or Bachelor
 - English proficiency
 - Informatics proficiency
- Improving continuous education: Specialized nursing courses.
- Scholarships to study PhD degree in nursing overseas

- Lack of nurses who have PhD degree in order to train master degree and do nursing management in Vietnam.
- Begin to implement the competency-based nursing curriculum.

Nursing research

- Enhance the nurse's research competencies
- Orientate nursing studies to clinical areas and teaching-learning methods.
- Publish the results of study in nursing local, regional, national and international journals.

Human resources

- Social demands for providing nurses with high qualifications are increasing
- Nursing shortage in quantity and quality with an imbalance in manpower structure.
- Differences in the qualifications among urban and rural areas and hospital level.
- Lack of appropriate policies to attract and maintain nursing workforce in terms of health care service and nursing education.
- No differentiation in nursing practice areas based on degrees in nursing education, the nurse does not perform their role and function in nursing profession.
- Increase the awareness of role, function, and position of nurse in society.

Textbooks and Library

- Lack of nursing textbooks and materials for student learning and their references.
- Lack of access to data bases for literature searches.
- Lack of access to full text journal articles for evidence based practice.

- For students who do not read/write English, limited teaching resources including textbooks, web-based searches and other teaching/learning materials.

Conclusion

Vietnam nursing goes through some promising development in nursing education as the following:

- Develop nurse educators' qualifications with master degree and PhD degree in nursing throughout national and international nursing education.
- Improve nurse educators' English abilities and computer skills
- Improve quantity and quality of nursing education step by step.
- Improve competencies and nursing professionalism, nursing leadership and management.
- Improve quality of nursing care services.
- Successfulness in marketing and affirming Vietnamese nurses' images through nursing education and providing health care services.
- Increasing nursing prestige with the health care professionals and the people.
- Having good opportunities and standards to be a member of International Committee of Nurses (ICN).
- Have good relationships with international nursing organizations and health care institutions as well as nursing schools in ASEAN countries and around the world.

NURSING SERVICES IN VIETNAM

Huỳnh Thị Phương, MSN

Chief Nurse,

Medical Professional Office, Department of Health Ho Chi Minh City

Abstract

The results of the National action plan for strengthening the nursing and midwifery from 2002 – 2010: improving organization system, human resource development, policy development, the training system and practice standard are equivalent to the average country in ASEAN. Despite these remarkable achievements, but nurses and midwives are still low quantity: 11,7 per 10,000 habitants and quality: 85.1 % secondary level, faced with many challenges and problems in meeting the demand for essential health care for patients, residents and meet the requirements of international integration. Decision of the Minister of Health for National Programmed of Action for Strengthening Nursing and Midwifery Services from now to 2020. Along with the support of organizations within and outside the countries, Hoping, this is a milestone marking to continuous the development of Vietnamese nurse and midwife in the future.

Introduction

Vietnam country has an area of 331.212 km², with a population density has about 86 million people, is the 13th most populous country in the world. Over the past, thanks to the efforts and determination of Vietnam's health sector, the

health care has made important achievements, the hospital system has gradually modernized equipment, professional qualifications, serving attitudes of health workers is raised; prevention efforts in many control disease. However, the current health care system is facing the challenge of service quality, cost, ethics, fairness and satisfaction of the patient, the problems people and society are concerned.

Along with the development of health care system, nurses and midwives are constantly learning and improving the professional standards. However, we are still facing the challenge of nursing quality and quantity. The rate nurses and midwives / doctors in health care facilities is very low: 1.6, directly influence the quality caring and health care services. In recent years, the quality of human resources has improved markedly, various nurse and midwife types are formed; bachelor, masters, specialist doctorate. However, 85% nurse and midwife are at the secondary level (MOH, 2010). Thus, Vietnam has only 15% nurses and midwives with college and undergrated degree, these training standards is equivalent standard of ASEAN and recommended by Word Health Organization.

Since, Vietnamese Nursing Association (VNA) established, has contributed promotes advocacy and policy development from the Ministry of Health nursing and medical facilities. Due to the number of VNA spreads all the country, with three levels, the Ministry, Provincial / City, Nursing Associations and Nursing Teacher Association. In the closed future, Coordination with VNA to establish nursing and midwifery council to evaluate and grant practicing certificates for nurse and midwife.

Health Care Needs & Nursing Needs

Vietnam is facing the dual burden of disease due to the shift of disease pattern from main infectious diseases to non-communicable diseases: accidents, poisoning, trauma, heart disease, cancer, diabetes.... While A group of infectious diseases such as influenza A (H1N1, H5N1) and the risk of disease spreads to the community and death rate can occurs at any time. The group B infectious diseases such as dengue fever, malaria, and infectious hand-foot-mouth disease in different

seasons, there is always the risk of development and outbreaks. Disease risk can occur at any time to increase the burden of disease, which affects the health, social security and increased risk of occupational exposure of medical staff.

The size of Vietnam's population increases every year, population structure fluctuations, aging index (the total number of people > 60 years old / people under 15 years of age) increased from 24.5% in 1999 to 35, 9% in 2009). The population growth and population aging rapidly increase caring needs, especially health care for the elderly in the future. At the same time, groups of women age entering childbearing is very large, will greatly affect the demand for health care services and pediatric reproduction. So caring becomes essential to everyone, every home.

In recent years, developing into highly specialized fields that development requires specialized nursing and midwifery should be commensurate with the medical development and ensure the most professional team. Economy growing, perceptions and attitudes about the health of the people change, and require health care standards high quantity and quality. This requires standards to enhance caring.

On the other hand, economic growth makes to tend increasing the gap between the local poor, regions, between populations. This is an important factor affecting inequity in using of health services. The health care sectors will have a very important role in enhancing people's health care services, public policy for the poor and vulnerable. This requires increasing nursing and midwifery resources with quality and quantity to meet the caring needs of the growing population.

Health Care & Nursing Systems

Over the past decade (from 2001 to 2010), the health sector has made care strategy, protected people's health, achieved significant results in improving the health status of the people. The beneficiaries of the health services of the people increased markedly. In the achievement of the health sector, there is a significant contribution of nurse and midwife services.

In particular, the implementation of the National Plan to strengthen nurse and midwife (2002-2010) achieved the basic goals and set targets. Nurse and midwife management system has been established at health settings (See Figure 1). The role of nurse and midwife are confirmed and improved caring quality. Many policies for nurse and midwife was built, additions and amendments contribute to the position of nurse and midwife. The basic legal for nurse and midwife independent developers such as nursing competency basic standards, ethics nursing standard, salary and responsibility allowance for management.

Training system has developed into more specialized training from secondary level to college, undergraduate and graduate. Vietnam shortage of nursing teachers and lack of experts, although number of nursing teacher is increasing in recent years from 30% to 68% (2010) nurses and midwives not keep up with the development progress of the world, we still have not been trained to perform caring standards and professionalism.

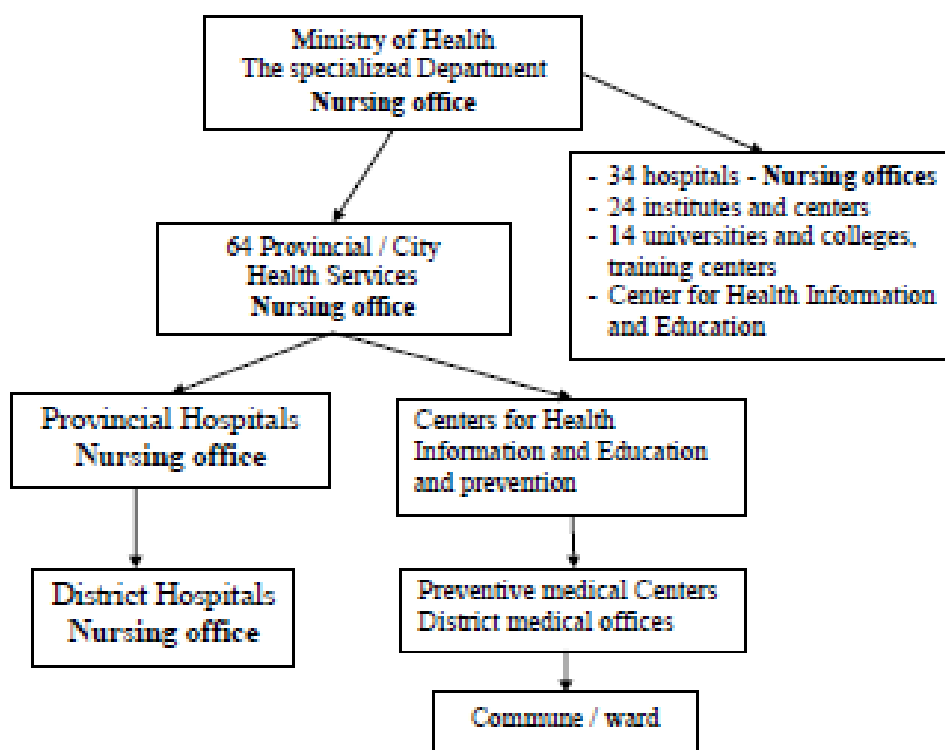

Figure 1: Nursing system in Vietnam.

Level of Nursing Staff including Education and Competency

Training and career development

In recent years, the nursing and midwifery training system have developed including 64 colleges, universities in all provinces and cities, nationwide have been strengthened in terms of the number and training levels. Number of nursing and midwifery students graduated is increasing significant, from 15,820 graduated students in 2008 to 39,835 graduated students until now (Data from department of science and training). Every year, each hospital or center has continuous training program for nursing and midwifery to improve knowledge and skills to caring and teaching courses are updated and established.

In comparison with the 5-year Health sector plan for 2011–2015, some indicators on health human resources remain lower that estimates for 2010 and may be difficult to achieve without major changes in health human resources policies. Data for 2009 indicate The ratio of nurses to doctors has increased very little (1.2 in 2008 and 1.27 in 2009) indicating that there has not yet been any substantial change in the number of nurses and midwives working in the state health sector. The rate of nurse and midwife per 10.000 habitants is still low compared with growing population.

Nursing and midwifery competency

Management of Nursing

Nursing management system, from the Ministry of Health to the Department of Health and Hospitals has been established and operating effectively. To improve qualified nursing leader, chief or head nurse are appraised every 5 years. However, the ratio of high level of nursing chief, head nurse and supervisor is still low at 30%, this is a challenge in the future.

Nursing competency

The current nursing education system, accordingly clinical practice and the working environment, associated with differences in nursing competence in

Vietnamese nurses. After graduation, nurses and midwife will have the first class for orientation if they start working in health sector, after that they start participating in patient care without any evaluation of their clinical competence during their employment. Their daily responsibilities are assigned according to the nature of nursing work in each clinical unit and the hospital policy. Every year, hospitals have plan for continuous training for nursing and midwifery staffs.

Demand and Supply of Nursing Staff

The people's needs and demand for health care is increasing, risk factors negatively affecting health are tending to increase and the quality and quantity of nurse and midwife to care and protect the people's health remains low. To supply this manpower in the health sector, it is important to enhance caring quality, improve satisfaction in health care services and affirming the role and image of nurses and midwives, especially, integration into ASEAN countries and the world.

Licensing

On 14 November 2011, the Ministry of Health promulgated Circular 41 guiding procedure of granting professional certificates for individuals and operation license for organizations in health care sector. To have professor certificate, Nurses, midwives and technicians have worked before 01/01/2012, if they have time and practice in health setting at least 09 consecutive months in health setting, was confirmed with enough practice time. However, if nurse, midwife and technicians don't have worked in any health setting in two years, they don't allow to be supplied for license. Nurses are allowed to practice with official requirements for updating their knowledge and skills at 24 hours per year. This is responsible for issuing regulations, duties and the scope of nursing practice.

Today, Vietnam has not nursing and midwifery council, we are going to establish in 2015, this is plan of the National Programmed of Action for Strengthening Nursing and Midwifery Services from now to 2020. The

Coordination with the VNA to evaluate and grant practicing certificates for nurses and midwives. Coordinate activities with Vietnamese Nursing Association. In the process of policy development for nursing and midwifery, Vietnam Nursing Association has contributed much effort and close collaboration with the MOH and other relevant ministries to promote the process of advocacy and policy development.

Nursing Staff Development/Training Course

In 1946 Vietnam country had only primary training for nursing, nurse recruitment first class. Today, there are 64 colleges and universities for nursing and midwifery students to study college, under graduate, specialist 1 and master. Ministry of Health provided the official correspondence to guide developing program and curriculums with the main principles.

During the development of Nursing Vietnam, we have a lot of international nursing organizations help both mental, physical knowledge and material. You helped us all about funding, knowledge and resources. We can not forget the precious help of the international nursing, you who helped us to understand career and strive for Vietnam nursing career development.

Research Development

Research was the lowest in these practice competencies (Phượng, 2011). This might be explained by the fact that nurses had no understanding of research because it was not included in nursing education program (2 year educational program). In recently years, after graduated nurses and midwives in undergraduate program, we are going to develop nursing research, and nursing magazines is established every quarter. This is developed for evidence-based practice of nurses and midwives.

Challenges of ASEAN Economic Community for Nursing Services in Vietnam

Nursing care not meet needs of the patient

Due to lack of manpower, most health settings have 24 hours / nursing shift, and few 8 hours or 12 hours/ nursing shift for special departments such as ICU. Many hospitals, during a night shift, there is one nurse or midwife to monitor and caring from 20 to 30 patients. All most family numbers care patient in hospitals. In other hand, facilities and equipment for patient caring is very limited and does not meet the standard of caring regimen and nutrition daily, In the hospital, patients are supplied beds, linens and equipment for the minimum activity, the rest of the patients lack of basic needs.

Today, healthcare environment is very much pressure and risk factors for health doctor, nurses and midwives. While working environment for health workers, particularly for nurses and midwives are still limited in facilities, equipment, living conditions, lack of necessary equipment for the application of room universal vaccine for HIV / AIDS, sexually transmitted infections and other serious diseases. Changing disease patterns with the increasing emergence of non-communicable diseases associated with an aging population and rising hospital costs, it is necessary to strengthen home care. However, the health care system in the present undeveloped social needs promptly.

Doctors, nurses, midwives, especially those who work in the hospital with a large of patients, at the same time to solve for many patients, there is not much time to communicate with patients can lead to risk of medical errors due to unintentional is huge. The patients have a long time to wait getting medical treatment and care. Therefore, the workload adjustment of nurses and midwives through the application of measures against hospital overcrowding and increase the number of nurses and midwives to apply the correct ratio nurses and midwives / hospital beds / doctors, It is the important breakthrough to enhance service quality in the coming years.

Patients in the hospital or receiving medical services largely exposed to nurses and midwives. However, there is still a part of health worker have not been rated, and created patient satisfaction, thus making the patient as unhappy. Moreover, the process of evaluating the work of the nurses and midwives are not considered communication with customers is an important criterion. This is a required field of active intervention in the near future in order to increase patient satisfaction is one of the criteria for evaluating the quality of health services.

Policies system, nursing competency standard

Currently, policy system, nursing standards in Vietnam has not completed compared with international standard. That is important for independent development of nurses and midwives. Vietnam just has the code of ethics of nursing practice (Code of Ethics for Nurses and Midwives), that is also a restriction leads to the above exists. The promulgation of the Code of Conduct for nurses and midwives will be the basis to meet the requirements of health care quality. Due to lack of clinical practical hierarchy of nurses and midwives in different training levels, leading the assigned practice did not differ between the training levels. Nurses and midwives lack autonomy which mainly depends on the ordering physician. This has led to the fact that nursing and midwifery career remain to not be seen as independent practitioners. In the future, nursing practice in health care system needs to be clarified. Besides, due also affected by attitudes as the nurses and midwives is the maid for a doctor's professionalism.

Currently, Vietnamese nurses just have nursing basic standard (2012), in the future, to influence the development and evaluation of materials related such as nursing student curriculum, assessment of student competence in the learning process, and nursing and midwifery in the process of work, the policy regarding use of nurse and midwife and licensing practice. Vietnam is one of the few countries which have not established the nursing and midwifery council. The absence of this Council has limited the participation of nurse and midwife in the process of building and implementing policies related to these areas.

Lack of Manpower

Vietnam country lacks of both nursing and midwifery quantity and quality, but the structure is not uniform, and although the number of human nurses and midwives has increased over each year, but the rate nurses and midwives (35 persons / thousand population, 2009) puts in the group of countries with low rates by the recruitment policy at the health facility. According to statistics of the World Health Organization in 2008, the ratio is only 1.4 in Vietnam ranked in the lowest in Southeast Asia. Rate nurses and midwives / doctors in health care facilities is very low, directly influence quality health care services. Although the amount of nurses and midwives annual graduation but do not have enough lack of staffs.

In recent years the quality of human resources nurses and midwives has improved markedly, nursing and midwifery various types are formed. Even so, 85% force was at the secondary level (hospital test results in 2010). Thus, Vietnam is only 15% DDV, HSV have college degree, equivalent university training standards these governments of ASEAN countries signed the Agreement on mutual recognition in services and recommended by World Health Organization.

The issue of concern is the growing of medical application in scientific achievements in the treatment and specialty chemicals increasing, requiring doctors, nurses, midwives work closely together in the subjects. While, Vietnam only has a handful of specialized training for special nursing and midwifery levels limitedly. Currently there is an imbalance in the structure and distribution of health workers, in rural and disadvantaged areas. Human Resource, highly qualified nursing and midwifery mainly concentrated in urban areas and major centers. Status human movement, from lower to higher levels, in large cities is alarming, affecting the security of the health workforce needed in rural, mountainous and health care basis.

Training quality

Currently, due to serious lack of teaching staff, specialized nursing and midwife with degree and clinical skills. Training quality not meet professional standards, practical ability, communication skills with patients and family members of patients. Training materials in universities and colleges have no clear hierarchy for levels. Vietnam established the nursing competency standard, training courses are been preparing for equivalent to the standard of the ASEAN region and recommended standards by the World Health Organization. The training schools often lack funding to upgrade the basic lab, medical subjects, clinical nursing practices, while subjects are the backbone of a training program, this situation really affect the quality of education, especially the nursing and midwifery practical competency.

Basis of clinical practice do not meet the needs of the student. Many schools do not have the facility to practice clinical sample of students, the students are learning about professional skills and practice ethical behavior as well as communication with patients and relatives of patients. Lack of practice faculty numbers guidelines clinical experience, leading practice difficulty. Therefore, the ability of students to work after graduation is limited by the learning process is not practiced as much as. In other hand, the secondary education system and colleges and universities are now very spontaneous, unplanned, there is no coordination of agency functions. Training quality is not uniform due to the gap of nursing competency teachers. This setting requires strict quality control and quality assessment required prior to issuance of practicing certificates for nursing and midwife, especially the secondary school level education.

Conclusion

Despite these remarkable achievements, but nurses and midwives are still faced with many challenges and problems in meeting the demand for essential health care for patients, residents and meet the requirements of international integration. Currently, Vietnam still lacks a lot nurses and midwife compared to

the targets set out in the master plan to develop the health system in Vietnam during 2010 and vision to 2020. National Programmed of Action for Strengthening Nursing and Midwifery Services from now to 2020, we need trying to achieve the goal of quality care, efficiency and safety in the health care settings. to integrate into the ASEAN countries and the world.

References

- General statistics office of Vietnam. (2013). “Education, health, culture and living standard”. Retrieved from <http://www.gso.gov.vn/default.aspx?tabid=395&idmid=3&ItemID=12639>.
- Luu, B. N. (2013). “Nursing management training in Vietnam”.
- Ministry of Health. (2013). “National Programmed of Action for Strengthening Nursing and Midwifery Services from now to 2020. Decision 1215/QD-BYT”.
- Muc, Đ. P. (2013). “The results of the National action plan for strengthening the nursing and midwifery from 2002 – 2010”.
- Phượng, T. H. (2011). “Nursing competence as perceived by staff nurses in three Vietnamese public hospitals”. Thesis from Ajou University-Korea.
- Vietnam Ministry of Health. (2011). “Strengthening management capacity and reforming health financing to implement the five-year health sector plan 2011–2015”. Joint Annual Health Review 2011.

NURSING EDUCATION IN THAILAND

*Assoc.Prof. Pol.Capt. Yupin Aunguroch, Ph.D., R.N.
Dean, Faculty of Nursing, Chulalongkorn University*

Today, nursing education in Thailand is making strides to catch up with the healthcare need, economic changes in the society throughout the region and around the world. Thailand has achieved progress in the nursing education system that typically prepared nurses who have specific competencies in each level to support health problem for the people. Not only for Thai people, but also for international especially in ASEAN people. Therefore, preparing nursing education in Thailand is needed for the kingdom's entry into the ASEAN Economic Community (AEC) in 2015.

History of Nursing Education in Thailand

- 1896 The first nursing school in Thailand was established.
- 1956 The first baccalaureate degree program for nursing was established at Siriraj.
- 1967 The first 2-year post basic baccalaureate degree program in nursing education was established at Chulalongkorn University
- 1971 Khon Kean University established nursing as an independent professional development with the creation of the first Faculty of Nursing.
- 1973 The Faculty of Education established the first master's degree program in nursing administration at Chulalongkorn University.

- 1978 All nursing colleges required 4 years of education. Then, in response to the shortage of nurses particularly in rural areas, 2 year technical programs were established.
- 1984 The Faculty of Public Health of Mahidol University began the first doctoral program in public health nursing.
- 1990 A collaborative doctor of nursing science degree program involving four public universities was created.
- 1997 The first PhD degree in nursing was also started at Chiang Mai University.
- 1999 An international PhD program began.
- 2002 The first Flexible Learning for Master in Nursing Science was began at Chulalongkorn University.
- 2007 The second Flexible Learning for Master in Nursing Administration was began at Chulalongkorn University.

Nursing educational system & curriculum

In Thailand, nursing and midwifery is included in a pre-registration program, therefore, there is no separate entry. Graduates will be issued with both nursing and midwifery licenses. The level of nursing education in Thailand was showed in figure 1.

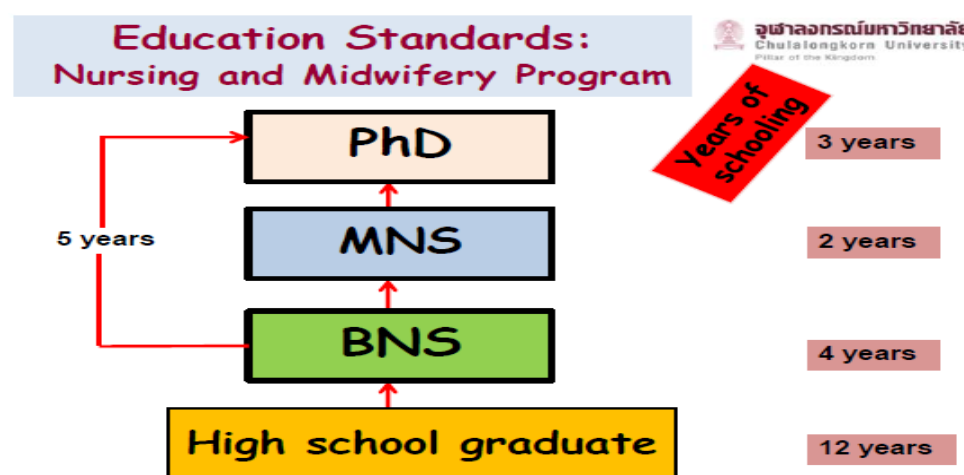

Figure 1: Level of Nursing Education in Thailand

Bachelor of Nursing Science Program (B.N.S.)

Every B.N.S. must meet the Standard of the Professional Nursing Program that is set by the Office of Higher Education Commission and the Thailand Nursing and Midwifery Council. Total credits of the B.N.S. program range between 130 and 150. The program comprises a minimum of 30 credits in general education, 24 credits in pre-professional courses, 70 credits in professional courses and 6 credits in electives. Most of the programs are organized to include between 144 and 147 credits. The graduates from the B.N.S. program are qualified to practice as professional nurses in all setting. However, they must obtain the Professional Nurses License granted by the Thailand Nursing and Midwifery Council prior to starting practice.

Master of Nursing Science Program (M.N.S.)

All M.N.S. programs required two years of study. The curriculum varies from institutions to institutions. A total minimum credit is 42. Most of the programs organize coursework in four groups: core course, major courses, elective courses, and thesis. Fifteen credits for core courses, 12 credits for major courses, 3 credits for elective course, and 12 credits for thesis.

The applicant's qualifications are Bachelor's degree in nursing with GPA no less than 2.50, holding the Nursing License for First Class of Nursing Professional and Midwifery, and have a minimum of 1-2 years of experience in nursing practice.

Doctor of Philosophy Program in Nursing Science

This program aims at preparing nurse scholars with academic and research capabilities to develop nursing knowledge leading to improvement of quality of nursing services, education, research, and administration, as well as health care system. The Doctor of Philosophy (Ph.D.) in nursing science is an international post-baccalaureate program designed for international and Thai nurses, in collaboration with other well-developed nursing schools from abroad.

The applicant's qualifications are Master's degree in nursing with GPA no less than 3.50, holding the Nursing License for First Class of Nursing Professional and Midwifery. In addition, English language knowledge considered from a TOEFL score of over 525 (based on requirement of university).

Program of Nursing Specialty

Nursing Specialty Program is designed as four months program. Coursework is organized with minimum 15 credits. There are 2 credits in core courses, 8 credits in nursing specialty courses, and 5 credits in practicum courses (or practice \geq 300 hrs).

Currently, Thailand has 135 programs of nursing specialty such as 62 programs for nursing field, 2 programs for nursing administration, 6 programs for nurse teaching, 38 programs for nurse practitioner, and 27 programs for other field (Center for Continuing Nursing Education (CCNE), 2013).

The applicant's qualifications are Bachelor's degree in nursing, holding the Nursing License for First Class of Nursing Professional and Midwifery, and have a minimum of 2 years of experience in nursing practice.

Nursing with specialty program

- Nursing Administration/Management
- Critical care
- Emergency, trauma and disaster preparedness
- Chronic care
- Renal dialysis, CAPD
- Wound care, ostomy and urinary incontinence
- Cardiovascular nursing

Categories of Nursing and Midwifery

- Registered Professional Nurse
- Registered Technical Nurse
- Certified Nurse Practitioner (4 months training)
- Nurse with specialty (4 months programs)

- Advanced Practice Nurse (post-masters)

Advanced Practice Nurse

- Pediatric Nurse
- Medical and Surgical Nurse
- Gerontological Nurse
- Mental Health and Psychiatric Nurse
- Maternal and Child Nurse
- Advanced Midwifery Practice
 - Nurse Anesthetist
 - Infection Control Nurse
 - Community Nurse
 - Community Nurse Practitioner

Demand and supply of nurse educators, nursing schools

Nursing education in Thailand has been provided by several concerned sectors (Table 1). These are:

- The Ministry of Education (at a Bachelor, Masters' and Doctoral levels provided in universities)
- The Ministry of Public Health (at a certificate level equivalent to a Bachelor degree level)
- Private Universities and Colleges
- Military nursing schools
- Police Department
- Bangkok Metropolitan

Currently, 82 nursing schools and colleges provide educational programs at BSN level, of these 7 schools provide graduate programs in nursing. Selected indicators for quality of nursing education include 1) percentage of passing nursing licensing examination, 2) percentage of job placement, 3) evaluation from employers, 4) evaluation from students and graduates, 5) number of publications

teaching staff per capita, and 6) students awards, faculty awards at national or international level.

Table 1: Nursing education in institutes in Thailand (The Thailand Nursing & Midwifery Council, 2013)

Organizations	Number
The Ministry of Education	
Under graduate	20
Graduate	7
The Ministry of Public Health	29
Private Universities, and Colleges	21
Military nursing schools	3
Police Department	1
Bangkok Metropolitan	1
Total	82

A study of supply and requirement projection of professional nurses in Thailand found that future demand of nurse educators in the year 2015 was 6,833 (4.95%) (Srisuphan et al., 1998) (Table 2).

Table 2: Future requirements for Thai professional nurses by health demand methods.

Demand Components	Year			
	2000	2005	2010	2015
Nursing services	54,986 (85.41%)*	110,075 (91.02%)	115,722 (90.28%)	123,640 (89.60%)
Teaching	6,333 (9.84%)	6,833 (5.65%)	6,833 (5.33%)	6,833 (4.95%)

Occupational health nursing	1,000 (1.55%)	1,000 (0.83%)	1,000 (0.78%)	1,000 (0.73%)
Mental health nursing	1,209 (1.88%)	2,122 (1.76%)	3,678 (2.87%)	5,524 (4.00%)
Management and Technical	850 (1.32%)	900 (0.74%)	950 (0.74%)	1,000 (0.73%)
Total	64,378	120,930	128,183	137,997

Qualification of nurse educators

In Thailand, the qualification of nurse educators is designed to ensure quality of instructors. The qualification of nurse educators is different in each level of education.

Bachelor of Nursing Science Program, nurse education must have nurse educator must have at least Bachelor degree in nursing or a related field, holding the Nursing License for First Class of Nursing Professional and Midwifery.

Master of Nursing Science Program, nurse educator must have at least Master degree in nursing or a related field, holding the Nursing License for First Class of Nursing Professional and Midwifery.

Doctor of Philosophy Program in Nursing Science, nurse educator must have a doctorate degree in nursing or a related field, holding the Nursing License for First Class of Nursing Professional and Midwifery. In addition, English language knowledge considered from a TOEFL score of over 550 (based on requirement of university).

Program of Nursing Specialty, nurse educator must have at least Master degree in nursing or a related field in area of specialty, holding the Nursing License for First Class of Nursing Professional and Midwifery, and have a minimum of 5 years of experience in nursing practice in specialty area.

Nowaday, Thailand has 4,054 nurse educators, master degree is 69.46%, doctoral degree is 20.28%, and bachelor degree is 10.26% (Table 3).

Table 3: Qualification of nurse educators in Thailand, 2013

Organizations	Number	%
Doctoral Degree	822	20.28
Masters Degree	2,816	69.46
Bachelor Degree	416	10.26
Total	4,054	100

Nursing Education Accreditation

Every institution has to go through accreditation process organized by The Thailand Nursing and Midwifery Council to ensure quality of nursing practice. Nursing and Midwifery Council is responsible for accrediting the pre-registration programs, continuing education, training and graduate programs. Nursing and Midwifery Curriculum and the program shall be approved by the University Council before sending to Nursing and Midwifery Council for approval. If approved, it will be sent to the Higher Education Office of the Ministry of Education for approval and recognition. For the new institutions, Nursing and Midwifery Council will conduct an audit for the readiness of the institutions according to criterion and standards of accreditation before opening or starting admitting students.

For accreditation process, this will start by reviewing of self-study report submitted by all nursing institutions including curriculum. Site visit to clarify, verify and amplify program materials written. Teacher-student ratio, qualifications of nurse teachers, curriculum component, teaching-learning process, hospitals and communities for practice and evaluation process, learning equipments and materials, libraries: (books and journals, audio-visual, computers) will be explored and assessed. If meet requirements, TNC will grant the accreditation (1 to 5 years

according to standards). Recommendations for further development will be offered by the assessor team. Every year, each nursing institution shall conduct an internal audit which requires external expertise or school networks. Students graduate from accredited schools will be allowed to apply for licensing examination. Every 5 years the Office for National Education Standards and Quality Assurance (Public Organization) will conduct an assessment of the quality and standards of all education institutions for approval.

All graduate nurse-midwives or nurses from accredited nursing schools who pass the national licensing examination will be registered and given a license to practice from the Nursing Council. The Nursing Council requires renewal of the license every 5 years, requirement for renewal is 50 hours of continuing education. Those who hold active licenses are able to work throughout the country. Regulation of foreign-qualified nurses, applicant must hold nursing license from home country submit all credentials and transcript of records. The Reviewing Committee will evaluate and if appropriate the Nursing Council will authorize a special permit to work as a registered nurse for a certain period of volunteer work or to take licensing examination for professional work in Thailand.

Research development

The development of scientific research is vital to provide teaching methods based on evidence, develop critical thinking, as well as teaching strategies / learning to suit the current development this. Method of problem solving, critical thinking methods have been applied to educational programs help students process their application in nursing. The results from clinical studies have been covered in the lectures, to help students understand the importance of nursing research, as well as the value of evidence-based practice. E-learning, Problem-based learning and self-learning methods are increasingly being encouraged. In addition to nursing ethics are also included in the process of teaching / learning (Kunaviktikul, 2006).

Challenges of AEC for nursing education in Thailand

According to Thailand is move forward to the ASEAN Economic Community (AEC) in 2015. Therefore, it is the challenges of Thailand' nursing education to prepare or develop nursing education system.

- Ongoing research is vital to meet new challenges and curricula will need to be analyzed and revised periodically to ensure appropriately prepared graduates. This includes curricula development and implementation for both undergraduate and graduate levels. Moreover, there should be more doctoral prepared nurses and APNs, which will increase the standard of quality of care and education as a whole.
- Curriculum development should be emphasized on ASEAN health needs and outcomes and concerned on international standard. In addition, adding ASEAN language or cultural, ASEN health in elective courses.
- Developing International Training Program.
- Faculty development.
- Research and knowledge building should be concerned ASEAN Health needs and outcomes. Linking among research, education, and practice in nursing is also of vital importance for the improvement of nursing. Collaboration between nursing institutions should be actively encouraged to allow for cross-cultural research, education, and the sharing of knowledge for the benefit of all involved. Thai nurse leaders and educators must evolve to take on the challenges of the future to ensure that the nursing needs of the Thai and ASEAN people are met.

References

Center for Continuing Nursing Education (CCNE). (2013). *Name list of Program of Nursing Specialty were approved by Thailand Nursing and Midwifery Council*. [Online]. Available from:
http://www.ccne.or.th/news_detail.php?news_id=536. [2013, June, 28].

- Kunaviktikul, W. (2006). Nursing and nursing education in Thailand: The past, the present, and the future. *Nursing and Health Sciences*, 8, 199–200.
- Srisuphan, W., Senaratana, W., Kunaviktikul, W., Tonmukayakul, O., Charoenyuth, C., Sirikanokwilai, N. (1998). Supply and requirement projection of professional nurses in Thailand over the next two decades (1995 - 2015 A.D.). *Human Resources for Health Development Journal*, 2(3), 210-220.
- Thailand Nursing and Midwifery Council. (2013). Thailand Nursing and Midwifery Council. [Online]. Available from:<http://www.tnc.or.th/en>. [2013, June, 25].

NURSING SERVICES IN THAILAND; THE PREPARATION FOR ASEAN

*Uraiporn Janta-Um-Mou
Bureau of Nursing Ministry of Public Health*

Health Services in MOPH

The structure of Health service in Ministry of Public Health Thailand (MOPH) was divided into 4 main parts: Office of Permanent Secretary, Department of Medical Service, Department of Mental Health, and Department of Disease Control.

The office of permanent secretary is consisted of 33 regional hospitals, 83 general hospitals, 744 community hospitals, and 9,755 health promotion hospitals. The department of medical service is divided into 10 specialty institutes and 13 specialty centers. The department of mental health is consisted of 12 mental and psychiatric hospitals and 13 mental health centers. The department of disease control has 2 infectious disease control institutes.

Health Care Capacity

In Thailand, health care services classify into 5 levels: 1) Primary health care level in which services are provided by village health volunteers; 2) Primary care level, with entry point at the community level (health station or primary care unit) and with care provided by health professionals and other personnel. Services usually cover treatment of common illnesses, health promotion, disease prevention

and rehabilitation. High risk patients are referred for further diagnosis and treatment;

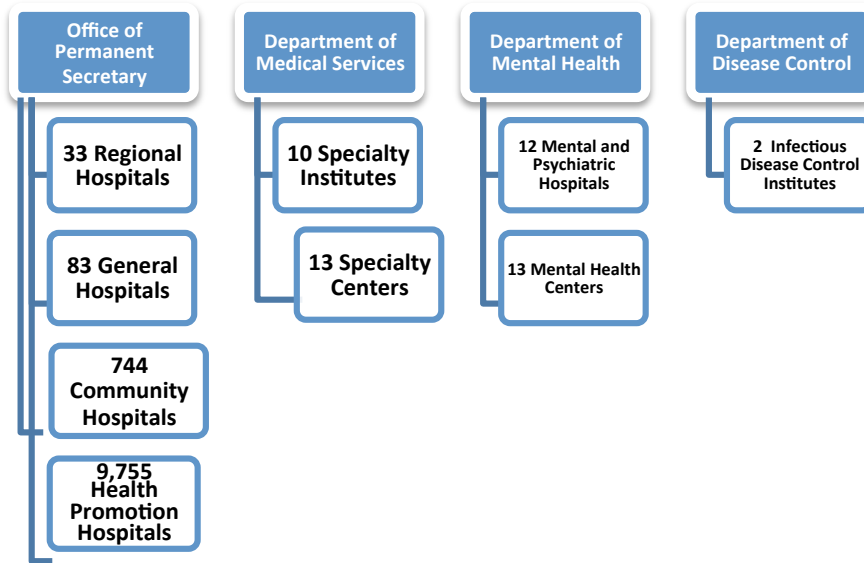

Figure 1. Health Care Classification

3) Secondary care level is for those who need appropriate investigations and treatment which is available at community and provincial or general hospitals. Services provided by physicians and other health professionals with intermediate specialization; 4) Tertiary care services are available at general, regional, and university hospitals and include provision of specialist care and the availability of high technology equipment and operations; 5) Specialized services refer to psychiatric and mental health hospitals and children’s hospitals. Private hospitals also provide 2-4 levels services. However, secondary and tertiary care facilities also provide primary care services.

The Level of Care	The Level of Hospital
<ul style="list-style-type: none"> • Tertiary to Super Tertiary Care • Specialty Care 	<ul style="list-style-type: none"> • Regional Hospital • National Institute • Specialty Center
<ul style="list-style-type: none"> • Secondary to Tertiary Care 	<ul style="list-style-type: none"> • General Hospital
<ul style="list-style-type: none"> • Primary Care 	<ul style="list-style-type: none"> • Health Promotion Hospital (HPH) • Primary Care Unit

Figure 2. Level of care and Level of hospital

Nursing Staff

Thailand nursing workforce current situation, there are registered nurses 173,625 totally, 165,639 are female, and 7,986 are male. There are 5,246 of technical nurses, 4,736 are female, and 510 are male (TNC, 2013).

	Male	Female	Total
RN	7,986	165,639	173,625
TN	510	4,736	5,246
Total	8,496	170,375	178,871

82,783 RN work with MOPH

TNC data: May,2013

Figure 3. Nursing Staff in Thailand

Nursing Staff Age Range

The most of age range among RN are during 25-49 years which are 75.13 percentages. Nurses' age below 25 years are 9.91 percentages. Nurses' age between 50-60 years is 14.97 percentages.

Age Range	RN		TN	
	n	%	n	%
< 25	17,642	10.16	93	9.91
25-29	28,395	16.35	76	15.92
30-34	26,420	15.22	110	14.83
35-39	32,792	18.89	311	18.51
40-44	22,112	12.74	439	12.61
45-49	22,706	13.08	1,012	13.26
50-54	13,879	7.99	1,123	8.39
55-59	6,227	3.59	1,643	4.40
60+	3,452	1.99	439	2.18
Total	173,625	97.07	5,246	100

Figure 4. Nursing Staff Age Range

The Level of Nursing Staff

Health service in Ministry of Public Health could be divided into many levels which are expert level (89), senior professional level (1,878), and professional level (80,816)

Level	Number n=82,783
Expert Level	89
Senior Professional Level	1,878
Professional Level	80,816
Operational Level	

Figure 5. Level of Nursing Staff

Nursing Service: The Driving System

Nursing practice in the 21th century faces a number of challenges including a growing population of hospitalized patients who are older and more acute ill, increasing health care costs, and the need to stay current with rapid advances in medical knowledge and technology. These challenges are complicated by existing shortage of nursing. In addition, new models of overall healthcare delivery are being developed that will impact the workforce and care delivery.

To address these challenges, nursing profession need to work effectively in tnter-professional teams to drive nursing system to work on providing nursing service. The cooperation of the variety fields in nursing organization are included Nursing Council, Bureau of Nursing, Nurses' Association of Thailand, and School of Nursing.



Figure 6. Nursing Service: The driving system

The Driving System in MOPH

In the part of MOPH, there are consisted of 4 levels in driving system. 1) Hospital level: in this level the responsible people who make the job work will be head nurses/chief nurse, and QA committee. 2) Provincial level: the functional team in this level are provincial chief nurse, provincial committee of nursing network for quality development. 3) Regional level: regional chief nurse, regional committee of nursing network for quality development, are the responsible team to drive system in this level. 4) National level: this level is responsible by Bureau of Nursing and National committee of nursing network for quality development.

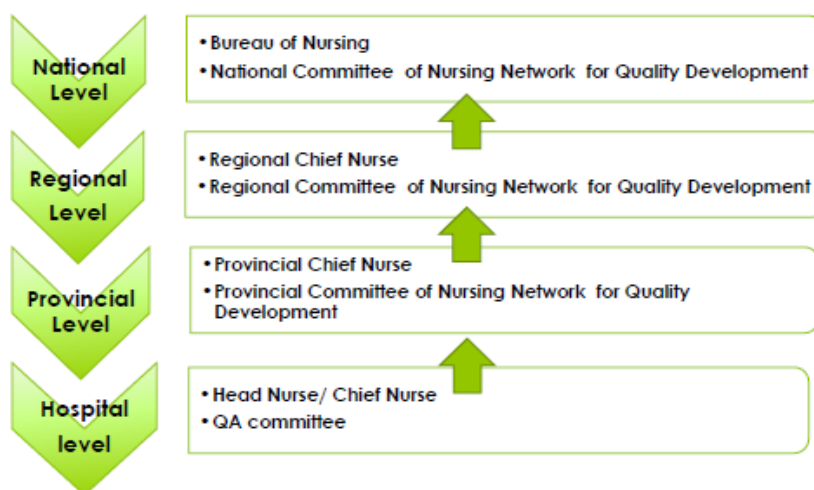

Figure 7. Four level driving system in MOPH

Nursing Service Strategies Formulation

Nursing organization both national and international has an effort to find out strategies in developing nursing service. For instance:

- WHO's Strategic Directions for Nursing and Midwifery (2011-2012)
- Agenda 64.7 strengthening nursing and midwifery
- Thai National Health Plan
- Thailand Nursing and Midwifery Strategic Plan
- Thai National Nursing Service Strategies (2013-2017)

The National Nursing Services Strategies

- Vision: (2013-2017): Excellence Quality of Nursing Services, Happy Nursing Staff on The Sustainable Way of Development for the Optimal Outcome of Healthy Thai Citizen
- National Nursing Service Strategies (2013-2017)
 - S1: Excellence Nursing Service Development
 - S2: Primary Nursing Development
 - S3: Disaster Nursing Service and Emergency Preparedness
 - S4: Nursing Network Strengthening
 - S5: Nursing Good Governance
- Nursing Service Strategies; Preparation for ASEAN (2013-2015)

How to Cascade to Action Plan?

- Integration of nursing Service action plan and service Plan
- Cascading of national nursing action plan to regional action plan
- Cascading regional action plan to provincial and hospital action plan

Nursing Quality for Health Care Setting

Quality assurance is a dynamic process through which nurses assume accountability for quality of care they provide. It is a guarantee to the society that

services provided by nurses are being regulated by members of profession. Quality of nursing care can be in the form of patient safety, patient satisfaction, and patient assurance. Therefore, quality of nursing care needs to be controlled by nursing profession.

- Nursing Quality Control: was controlled by
 - Nursing and Midwifery Standard which regulated by TNC
 - Nursing Quality External Audit
- Nursing Quality Assurance
 - Nursing Service Standard: is regulated by Bureau of Nursing that was focused on Hospital Based and Community Based.
 - Nursing Quality Assessment: Internal and External Audit
 - Nursing Quality Benchmarking: 3 categories of Benchmarking
 - ✓ Benchmarking between the same capacity of hospital setting
 - ✓ Benchmarking between the same area of hospital setting
 - ✓ Benchmarking between the same topic of nursing best practice

Nursing Quality Award

Nursing quality award is a recognition program that identifies excellence in overall performance in nursing quality indicators, tracks a broad range of outcomes that indicate the quality of nursing service.

Nursing Best Practice

- Criteria for Nursing Performance Excellence
- Training Program
- Award Applicants
- Assessors

Preparedness to ASEAN community

Thailand has been planning to be a member of AEC which prepare for the 2015. The government has adopted the eight-point strategic plan. The plan

outlines the strength and weakness of Thailand's overall capacity to engage the one ASEAN community. For nursing profession, we create a preparedness plan to ASEAN community.

Nursing Strategies; preparing to ASEAN Community

- S1: To do understanding and awareness among nurse professional in the paradigm shifting on nursing services
- S2: To prepare nursing staff's competency for readiness to global change
- S3: To develop workforce management system
- S4: To develop disaster nursing service and emergency preparedness
- S5: To improve the quality of nursing and step up to be a leader of nursing quality in ASEAN community

Nursing Workforce Development (S3)

Global Leadership Development

- CNOs Role and Capacity Building
- Quality Network Strengthening

Clinical Nurse Specialist and Expertise

- Trauma Center
- Cardiovascular Center
- Cancer Center
- Newborn Center

What's CNO Action in WHA?

- Adopting The Resolution of Nursing and Midwifery Agenda
- Integrating to the Thai Nursing and Midwifery Policy and Cascading to Nursing Service Action Plans
- Progress Report to the WHA Committee
- Progress Report to the WHO SEARO



Faculty of Nursing, Chulalongkorn University
Borommaratchachonnani Srisataphat
Building, Rama 1 Road, Pathumwan,
Bangkok 10330, Thailand
Tel. (662)-218-1131 Fax. (662)-218-1130

ISBN 978-602-71191-2-3



9 786027 119123